

簡短操作指南

！危險！

Attention: 注意：使用前，請閱讀原始製造商的說明。這些可以從www.halder.com/downloadcenter (1). 下載。

螺紋定位扣件被設計用在提升和維持負載（不能使用在人！！）。

螺紋定位扣件不適合用於負載旋轉。

髒物（例如，沙礫和碎屑，油和乳膠沉積物，灰塵……）可能會影響螺紋定位扣件的功能。

使用損壞的螺紋定位扣件會有危險。使用前，請仔細檢查螺紋定位扣件（例如：變形，斷裂，撕裂，損壞，螺紋元件遺失，腐蝕，解鎖功能）。

必須將帶螺紋的起重銷完全旋入螺紋，該螺紋可以真正測量並完全支撐在軸承表面上。當插入螺紋定位扣件時，必須防止負載旋轉。如果不使用螺紋吊銷，請避免直接撞擊它們。

損壞的螺紋定位扣件必須立即停用並維修。

禁止：

- 用顏色（尤其是紅色）標記螺紋吊銷
- 在超過 16,000 次負載循環後使用螺紋吊銷

螺紋吊銷的操作和作業只能由合格或受過指導的人員進行。只有在閱讀原始製造商的說明後，才能使用和維修帶螺紋的起重銷。

操作和荷重

要鬆開螺紋元件，請按按鈕（A）。要鎖定螺紋元件，請鬆開按鈕（A）。帶螺紋的提升銷必須完全旋入。

注意： 按鈕（A）藉由彈簧阻力彈回到初始位置後被鎖定。

請不要對按鈕長時間按著不放。

荷重 $F_1 / F_2 / F_3$ （請參閱第2頁）僅適用於帶有鋼製保持器的提升應用。

保養：

合格的人員必須每年至少一次停止使用螺紋定位扣件，以進行正確的檢查。

肉眼檢查：

沙粒和研磨，斷裂，撕裂，螺紋元件遺失和損壞，腐蝕，鉤環處的螺釘結合損壞。

性能檢查：

- 螺紋元件必須利用彈力自動鎖定
- 必須確保卸扣完全運動



(1) Original operating instructions

Short Instruction Manual

!DANGER!

Attention: Read the original operating instructions before use. These can be downloaded from www.halder.com/downloadcenter (1).

Threaded lifting pins are designed to lift and hold point loads (**not people!!**).

Threaded lifting pins are **not suited for the rotation of the load**.

Soilings (e.g. grits and grinds, oil and emulsion deposits, dust ...) can affect the functioning of the threaded lifting pins.

Using damaged threaded lifting pins can be perilous. **Before any use** carefully inspect the threaded lifting pins (i.e. deformities, breaks, rips, damages, missing threaded elements, corrosion, unlocking function). **Threaded lifting pins must be screwed completely into a thread that is true to gauge and bear completely on the bearing surface.** When inserting a threaded lifting pin, the rotation of the load must be prevented. **Please avoid direct impacts to the threaded lifting pins also if those are not in use.**

Damaged threaded lifting pins must be withdrawn from service immediately.

It is prohibited:

- to mark the threaded lifting pins in colour (especially red)
- to use the threaded lifting pins after exceeding 16,000 load cycles

The operation as well as work on the threaded lifting pins may only be carried out by qualified or instructed personnel. The threaded lifting pins may only be put into operation and serviced after the original operating instructions have been read.

Handling and Stress

To release the threaded elements, press button (A). To lock the threaded elements, release button (A). **Threaded lifting pins must be screwed in completely.**

Attention: The button (A) is locked after springing back to the initial position by means of the spring resistance.

Do **not** operate the button at charge.

The stress figures $F_1 / F_2 / F_3$ (see page 2) apply only to lifting applications with a steel retainer.

Maintenance:

Threaded lifting pins must be taken out of service for proper inspection by a qualified person(s) at least once a year.

Visual inspection:

Grits and grinds, breaks, rips, missing and damaged threaded elements, corrosion, screw union damages at shackle.

Performance check:

- the threaded elements must be locked automatically by the spring force
- full movement of the shackle must be ensured



(1) Original operating instructions

FR: La traduction dans votre langue de cet manuel d'instruction succinct et de la déclaration de conformité est disponible sur www.halder.com

IT: La traduzione di questo breve manuale di istruzioni nella vostra lingua con la Dichiarazione di conformità è disponibile nel sito www.halder.com.

ES: La traducción de este breve manual de instrucciones en su idioma con la Declaración de conformidad está disponible en www.halder.com.

CZ: Překlad tohoto krátkého návodu ve vašem jazyce s prohlášením o shodě je k dispozici na www.halder.com.

RO: Acest scurt instructaj de utilizare, tradus în limba dumneavoastră, împreună cu Declarația de conformitate sunt disponibile pentru descărcare pe www.halder.com.

PL: Tłumaczenie tej krótkiej instrukcji obsługi na Twój język wraz z deklaracją zgodności jest dostępne na stronie www.halder.com.

FI: Tämän lyhyen käyttöohjeen käänös omalla kielelläsi ja vaatimustenmukaisuusvakuutus ovat saatavilla osoitteessa www.halder.com.

SE: En översättning av denna korta instruktionsmanual med försäkran om överensstämmelse finns på ditt spark att hämta på www.halder.com.

NL: De vertaling van deze korte handleiding in uw eigen taal met conformiteitsverklaring is beschikbaar op www.halder.com.

KR: 적합선 선언과 함께 귀하의 언어로 번역이 된 짧은 설명서는 www.halder.com에서 확인 가능합니다.

CN: 可在 www.halder.com 上获得带有符合性声明的此简短说明手册的翻译版本。

TW: 可在 www.halder.com 上獲得帶有符合性聲明的此簡短說明手冊的翻譯版本。

JP: CE準拠の宣言書は、取扱説明書に付属していますが、以下URLでダウンロードできますwww.halder.com。

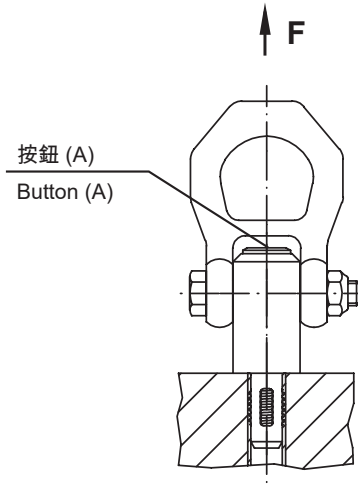

尺寸 / Dimensions														負載能力 根據 DIN EN 13155 / Load capacity according to DIN EN 13155			定位螺紋 / Locating thread	🌡️ max.	🏠 [g]	品號 / Art. No.	
d ₁	l ₁	d ₂ -0,07	d ₃	l ₂	l ₃	l ₄	l ₅	l ₆	l ₇	l ₈	l ₉	l ₁₀	F ₁	F ₂	F ₃	[mm]	[°C]	[g]	熱處理鋼 / Heat-treated steel	不銹鋼 / Stainless steel	
[mm]														[kN]			[mm]	[°C]	[g]		
M 8	12	6,62	21,5	17,8	25,7	36,0	27,0	30,0	49,0	87,5	21,5	8,0	2,1	0,9	0,8	M 8	250	274	22352.0008	22352.1008	
M10	14	8,35	21,5	20,0	25,7	36,0	27,0	30,0	49,0	87,5	21,5	10,0	3,9	1,5	1,5	M10	250	268	22352.0010	22352.1010	
M12	17	10,07	21,5	24,0	25,7	36,0	27,0	30,0	49,0	87,5	21,5	12,0	6,2	2,5	2,3	M12	250	273	22352.0012	22352.1012	
M14	17	11,80	21,5	24,0	25,7	36,0	27,0	30,0	49,0	87,5	21,5	12,0	7,8	4,2	2,9	M14	250	279	22352.0014	-	
M16	17	13,80	21,5	24,0	25,7	36,0	27,0	30,0	49,0	87,5	21,5	12,0	8,4	4,5	4,2	M16	250	284	22352.0016	22352.1016	
M20	22	17,25	30,0	30,0	36,5	52,0	32,6	36,0	56,0	114,0	30,0	17,0	16,6	7,7	5,8	M20	250	586	22352.0020	-	
M20	22	17,25	30,0	30,0	36,5	52,0	32,6	36,0	56,0	114,0	30,0	17,0	10,0	7,7	5,8	M20	250	519	-	22352.1020	
M24	27	20,70	36,0	36,0	42,0	60,0	50,6	49,8	82,0	152,0	36,0	22,0	23,0	11,1	8,6	M24	250	1187	22352.0024	22352.1024	
M27	31	23,67	45,0	40,0	42,0	60,0	50,6	49,8	82,0	152,0	36,0	26,0	33,8	15,7	13,7	M27	250	1546	22352.0027	-	
M30	35	26,10	45,0	45,0	42,0	60,0	50,6	49,8	82,0	152,0	36,0	30,0	42,3	21,5	15,5	M30	250	1596	22352.0030	-	

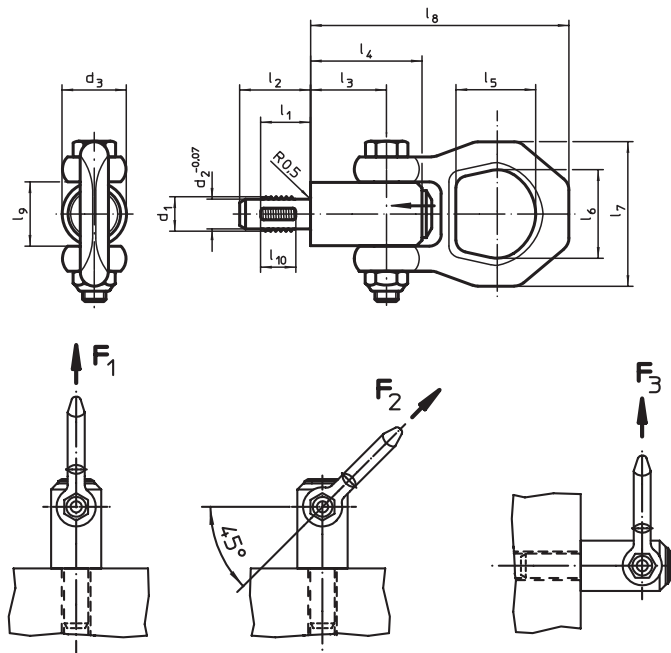

EC - 致性聲明 / EC Declaration of conformity

此產品符合 EC 指令 2006/42/EC.

This product is conform with the EC Directive 2006/42/EC.

製造商 / Manufacturer: *

地址 / Address: *

* 對文件負責 /
responsible for documentation

產品 / Product:

類型 / Type:

申請標準 /

Applied standard:

專利 / Patent:

Erwin Halder KG

Erwin-Halder-Strasse 5 - 9

88480 Achstetten-Bronnen / Germany

螺紋頂上銷 / Threaded lifting pins

EH 22352.

DIN EN 13155:2020

US 11649847 B2



Achstetten-Bronnen, 02.2024

S. Halder
Stefan Halder, 總經理 / General Manager