

## 操作手冊 / Operating Manual

### !危險!

帶手柄的提升銷設計用於提升和保持點荷載 (不是人!)

帶手柄的提升銷不適合負載的永久旋轉。

土壤 (例如砂粒和研磨物, 油和乳液沉積物, 灰塵) 可以影響具有手柄的提升銷的功能。

使用損壞的帶手柄的提升銷可能會造成危險。在任何使用之前, 仔細檢查帶手柄的提升銷 (例如: 變形, 斷裂, 撕裂, 損壞, 缺少球, 腐蝕, 解鎖功能)。

帶手柄的提升銷受損必須立即停止使用。

### 操作與荷重

壓下按鈕(A), 鋼珠鬆開。放開按鈕(A), 鋼珠鎖緊

**注意:** 按鈕(A)鎖緊是利用彈簧的回復力, 不要長時間按著不放

### !Danger!

Lifting pins with handle are designed to lift and hold point loads **(not people!)**

Lifting pins with handle are **not suited for permanent rotation of the load.**

Soilings (e.g. grits and grinds, oil and emulsion deposits, dust..) can affect the functionality of the lifting pins with handle.

Using damaged lifting pins with handles can be perilous. **Before any use** carefully inspect the lifting pins with handle (i.e. deformities, breaks, rips, damages, missing balls, corrosion, unlocking function).

**Damaged lifting pins with handle must be withdrawn from service immediately.**

### Handling and Load

Release the balls by pressing button (A). Lock the balls by releasing button (A).

**Attention:** The button (A) is locked after springing back to initial position by means of the spring force. **Do not operate the button under load!**

尺寸 / Dimensions										運送力量 / Carrying force	定位~孔 / Location hole	🌡️	🏠	參考 No. / Art. No.
$d_1$	$l_1$	$d_2$	$d_3$	$d_4$	$d_5$	$l_2$	$l_3$	$l_4$	$l_5$	$F_1$	D	max.		
-0,04 -0,08	+0,6				min.	±0,5				[N]	H11	[°C]	[g]	
[mm]											[mm]			
8,0	35	9,35	21,5	14	9,85	8,75	18,7	36,0	100	500	8,0	250	136	22351.0005
8,3	35	9,65	21,5	14	10,05	8,75	18,7	36,0	100	500	8,3	250	142	22351.0010
10,0	50	11,70	21,5	14	12,20	10,20	18,7	36,5	100	500	10,0	250	154	22351.0015
12,0	50	14,20	21,5	14	14,70	11,00	18,7	36,5	100	500	12,0	250	177	22351.0020

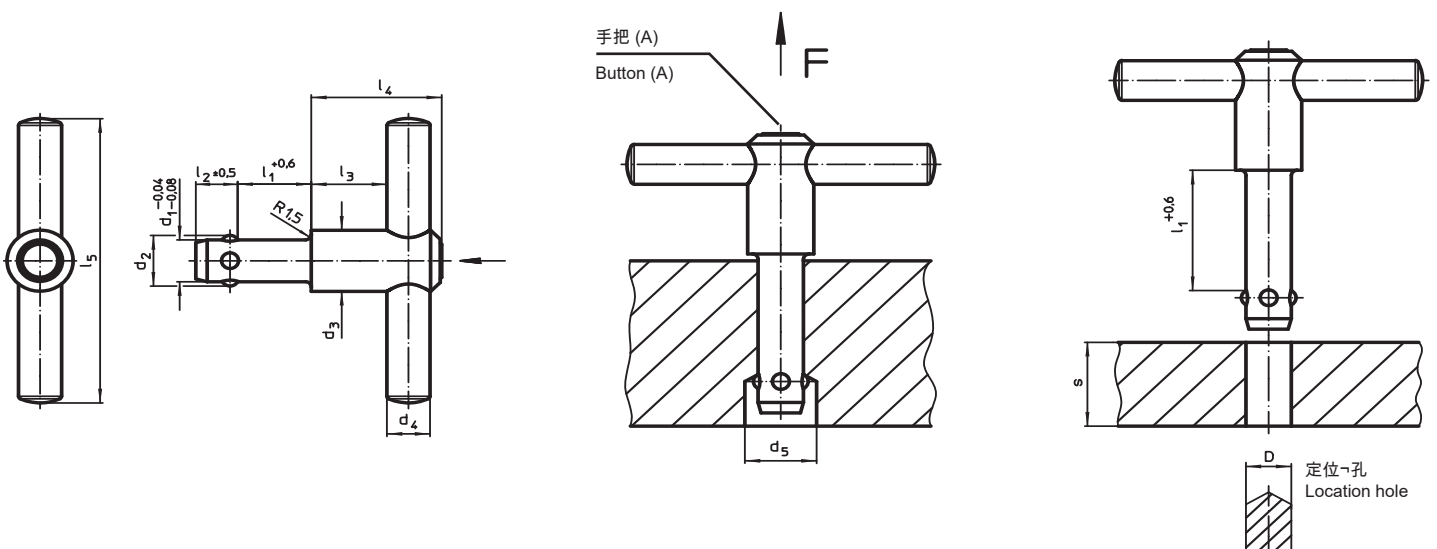

### 維護:

定位扣件每年至少 1 次要由合格人員作定期檢查

### 肉眼檢查:

磨損, 破裂, 撕裂, 鋼珠受損, 鉤環螺絲受損

### 特性檢查:

檢查鋼珠是否能彈回, 以及鉤環能否擺動

### Maintenance:

Lifting pins with handle must be taken out of service for proper inspection by a qualified person(s) at least once a year.

### Visual inspection:

Grits and grinds, breaks, rips, missing and damaged balls, corrosion or damages of the handle.

### Performance check:

Locking mechanism of the balls has to lock automatically by means of the spring force.

如果有疑問或發生誤解，德語版本的文件是至關重要的。

In case of doubt or in the event of misunderstandings, the German version of the document is crucial.

FR: La traduction du manuel d'utilisation original dans votre langue avec déclaration de conformité est disponible sous [www.halder.com](http://www.halder.com).  
IT: Le traduzioni delle istruzioni di produzione e le dichiarazioni di conformità nella tua lingua le puoi trovare al seguente indirizzo: [www.halder.com](http://www.halder.com).  
ES: Encontrará la traducción de las instrucciones originales del fabricante junto a la Declaración de Conformidad en su idioma en la página [www.halder.com](http://www.halder.com).  
CZ: Překlad originálního návodu k obsluze s prohlášením o shodě ve svém jazyce naleznete na internetových stránkách [www.halder.com](http://www.halder.com).  
RO: Traducerea instrucțiunilor producătorului și declarația de conformitate în limba maternă pe site-ul [www.halder.com](http://www.halder.com).  
PL: Tłumaczenie oryginalnej instrukcji obsługi oraz deklaracji zgodności w języku polskim znajdują Państwo na stronie internetowej [www.halder.com](http://www.halder.com).  
FI: Käännös alkuperäisistä valmistajan ohjeista vaatimustenmukaisuusvakuutuksineen löytyvät omalla kielellänne internetistä osoitteessa [www.halder.com](http://www.halder.com).  
SE: Du finner en översättning av tillverkarens instruktioner tillsammans med "letter of conformity" i ditt eget språk på [www.halder.com](http://www.halder.com).  
NL: U vindt de vertaling van de originele fabrikant instructies met de verklaring van overeenstemming in uw eigen taal op het internet onder [www.halder.com](http://www.halder.com).  
KR: 홈페이지 [www.halder.com](http://www.halder.com) 에서 해당국가의 언어로 제조사의 설명서를 보실 수 있습니다.  
CN: 您可以在以下网址找到中文版翻译的原厂操作指南与声明 [www.halder.com](http://www.halder.com).  
TW: 您可以在以下網址找到中文版翻譯的原廠操作指南與聲明 [www.halder.com](http://www.halder.com).  
JP: 使用説明書と製造者による EC 規則準拠証明は [www.halder.com](http://www.halder.com) からダウンロードできます。

## EEC - 致性聲明 / Original EC Declaration of conformity

此產品符合 EC 指令 2006/42/EC.

This product is conform with the EC Directive 2006/42/EC.

製造商 / Manufacturer: \*  
地址 / Address: \*

\* 對文件負責 /  
responsible for documentation

**Erwin Halder KG**  
**Erwin-Halder-Strasse 5 - 9**  
**88480 Achstetten-Bronnen**  
**Germany**



品名 / Product:  
品號 / Type:

**頂上梢 / Lifting Pin with handle**  
**EH 22351**

申請標準 /  
Applied standard:

**DIN EN 13155:2003+A2:2009**

Achstetten-Bronnen, 2020年10月

  
Stefan Halder, 總經理 / General Manager