

## 橡膠終端止動緩衝器 · 低型結構

EH 25150.



### 產品描述

彈性的，減幅的減噪軸承可以保護表面。橡膠緩衝件可被作為間隔件。  
硬度為 70 ±5° 支柱 A。

### 材質

軸承墊片

- 鋼，鍍鋅，鈍化

本體

- NBR

### 圖面

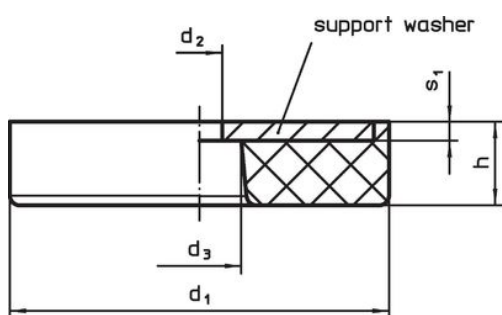

picture 1

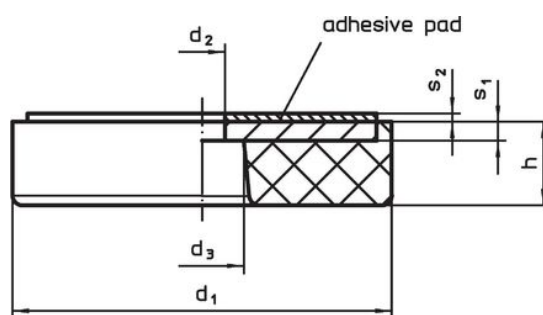

picture 2

### 訂單資訊

| d <sub>1</sub>    | h  | d <sub>2</sub><br>+0,5 | 尺寸                             |                |                | 彈簧比率 R<br>[N/mm] | 荷重能力<br>max.<br>[N] | 彈簧範圍<br>[mm] | 溫度          |      | 重量<br>[g] | 品號         |
|-------------------|----|------------------------|--------------------------------|----------------|----------------|------------------|---------------------|--------------|-------------|------|-----------|------------|
|                   |    |                        | d <sub>3</sub><br>+0,5<br>[mm] | s <sub>1</sub> | s <sub>2</sub> |                  |                     |              | min<br>[°C] | max. |           |            |
| 帶有通孔 – 相片 1       |    |                        |                                |                |                |                  |                     |              |             |      |           |            |
| 19                | 3  | 4                      | 7,5                            | 1,5            | 1,1            | 282              | 480                 | 1,70         | -30         | 120  | 2,8       | 25150.1119 |
| 19                | 7  | 4                      | 7,5                            | 1,5            | 1,1            | 213              | 373                 | 1,75         | -30         | 120  | 3,8       | 25150.1120 |
| 19                | 14 | 4                      | 7,5                            | 1,5            | 1,1            | 68               | 240                 | 3,50         | -30         | 120  | 5,6       | 25150.1121 |
| 25                | 3  | 4                      | 7,5                            | 1,5            | 1,1            | 1870             | 1870                | 1,00         | -30         | 120  | 5,4       | 25150.1125 |
| 25                | 8  | 4                      | 7,5                            | 1,5            | 1,1            | 349              | 698                 | 2,00         | -30         | 120  | 8,0       | 25150.1126 |
| 25                | 16 | 4                      | 7,5                            | 1,5            | 1,1            | 135              | 540                 | 4,00         | -30         | 120  | 12,0      | 25150.1127 |
| 32                | 4  | 5                      | 9,0                            | 2,0            | 1,1            | 1680             | 1680                | 1,00         | -30         | 120  | 12,0      | 25150.1132 |
| 32                | 9  | 5                      | 9,0                            | 2,0            | 1,1            | 548              | 1233                | 2,25         | -30         | 120  | 16,0      | 25150.1133 |
| 32                | 18 | 5                      | 9,0                            | 2,0            | 1,1            | 212              | 850                 | 4,00         | -30         | 120  | 23,0      | 25150.1134 |
| 38                | 4  | 5                      | 9,0                            | 2,0            | 1,1            | 1500             | 1500                | 1,00         | -30         | 120  | 17,0      | 25150.1138 |
| 38                | 10 | 5                      | 9,0                            | 2,0            | 1,1            | 704              | 1760                | 2,50         | -30         | 120  | 25,0      | 25150.1139 |
| 38                | 20 | 5                      | 9,0                            | 2,0            | 1,1            | 230              | 920                 | 4,00         | -30         | 120  | 37,0      | 25150.1140 |
| 50                | 5  | 6                      | 11,0                           | 2,5            | 1,1            | 3600             | 3600                | 1,00         | -30         | 120  | 39,0      | 25150.1150 |
| 50                | 11 | 6                      | 11,0                           | 2,5            | 1,1            | 1223             | 3670                | 3,00         | -30         | 120  | 51,0      | 25150.1151 |
| 50                | 22 | 6                      | 11,0                           | 2,5            | 1,1            | 500              | 2500                | 5,00         | -30         | 120  | 74,0      | 25150.1152 |
| 64                | 5  | 6                      | 11,0                           | 2,5            | 1,1            | 1460             | 1460                | 1,00         | -30         | 120  | 66,0      | 25150.1164 |
| 64                | 13 | 6                      | 11,0                           | 2,5            | 1,1            | 2016             | 6050                | 3,00         | -30         | 120  | 95,0      | 25150.1165 |
| 64                | 26 | 6                      | 11,0                           | 2,5            | 1,1            | 616              | 3700                | 6,00         | -30         | 120  | 141,0     | 25150.1166 |
| 帶有通孔以及黏著襯墊 – 相片 2 |    |                        |                                |                |                |                  |                     |              |             |      |           |            |
| 19                | 3  | 4                      | 7,5                            | 1,5            | 1,1            | 282              | 480                 | 1,70         | -30         | 120  | 2,9       | 25150.1219 |
| 19                | 7  | 4                      | 7,5                            | 1,5            | 1,1            | 213              | 373                 | 1,75         | -30         | 120  | 5,1       | 25150.1220 |
| 19                | 14 | 4                      | 7,5                            | 1,5            | 1,1            | 68               | 240                 | 3,50         | -30         | 120  | 6,9       | 25150.1221 |
| 25                | 3  | 4                      | 7,5                            | 1,5            | 1,1            | 1870             | 1870                | 1,00         | -30         | 120  | 6,9       | 25150.1225 |
| 25                | 8  | 4                      | 7,5                            | 1,5            | 1,1            | 349              | 698                 | 2,00         | -30         | 120  | 9,3       | 25150.1226 |
| 25                | 16 | 4                      | 7,5                            | 1,5            | 1,1            | 135              | 540                 | 4,00         | -30         | 120  | 13,0      | 25150.1227 |
| 32                | 4  | 5                      | 9,0                            | 2,0            | 1,1            | 1680             | 1680                | 1,00         | -30         | 120  | 13,0      | 25150.1232 |
| 32                | 9  | 5                      | 9,0                            | 2,0            | 1,1            | 548              | 1233                | 2,25         | -30         | 120  | 18,0      | 25150.1233 |
| 32                | 18 | 5                      | 9,0                            | 2,0            | 1,1            | 212              | 850                 | 4,00         | -30         | 120  | 25,0      | 25150.1234 |

| d <sub>1</sub> | h  | 尺寸                     |                        |                |                | 彈簧比率 R<br>[N/mm] | 荷重能力<br>max.<br>[N] | 彈簧範圍<br>[mm] | 溫度  |      | 重量<br>[g] | 品號         |
|----------------|----|------------------------|------------------------|----------------|----------------|------------------|---------------------|--------------|-----|------|-----------|------------|
|                |    | d <sub>2</sub><br>+0,5 | d <sub>3</sub><br>+0,5 | s <sub>1</sub> | s <sub>2</sub> |                  |                     |              | min | max. |           |            |
|                |    | [mm]                   |                        |                |                |                  |                     | [°C]         |     |      |           |            |
| 38             | 4  | 5                      | 9,0                    | 2,0            | 1,1            | 1500             | 1500                | 1,00         | -30 | 120  | 19,0      | 25150.1238 |
| 38             | 10 | 5                      | 9,0                    | 2,0            | 1,1            | 704              | 1760                | 2,50         | -30 | 120  | 26,0      | 25150.1239 |
| 38             | 20 | 5                      | 9,0                    | 2,0            | 1,1            | 230              | 920                 | 4,00         | -30 | 120  | 38,0      | 25150.1240 |
| 50             | 5  | 6                      | 11,0                   | 2,5            | 1,1            | 3600             | 3600                | 1,00         | -30 | 120  | 41,0      | 25150.1250 |
| 50             | 11 | 6                      | 11,0                   | 2,5            | 1,1            | 1223             | 3670                | 3,00         | -30 | 120  | 54,0      | 25150.1251 |
| 50             | 22 | 6                      | 11,0                   | 2,5            | 1,1            | 500              | 2500                | 5,00         | -30 | 120  | 77,0      | 25150.1252 |
| 64             | 5  | 6                      | 11,0                   | 2,5            | 1,1            | 1460             | 1460                | 1,00         | -30 | 120  | 71,0      | 25150.1264 |
| 64             | 13 | 6                      | 11,0                   | 2,5            | 1,1            | 2016             | 6050                | 3,00         | -30 | 120  | 99,0      | 25150.1265 |
| 64             | 26 | 6                      | 11,0                   | 2,5            | 1,1            | 616              | 3700                | 6,00         | -30 | 120  | 149,0     | 25150.1266 |

### 應用範例

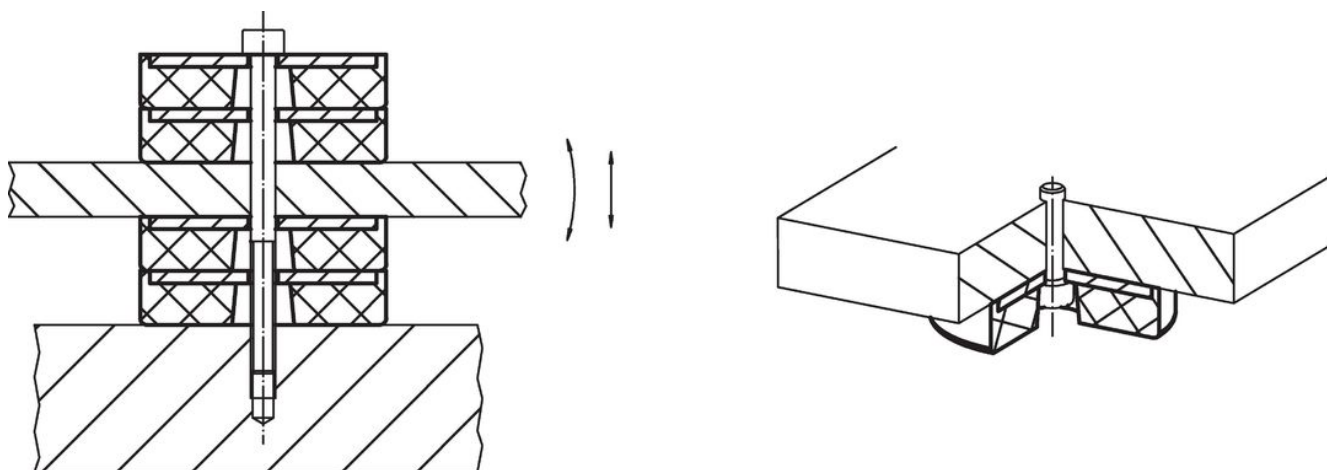

### 遵守

#### 符合 RoHS

含鉛 - 相容除了例外 6a / 6b / 6c.

#### 含有 >0.1% w/w 的 SVHC 物質

含鉛 - SVHC [REACH] 清單截至 2024 年 6 月 27 日

#### 包含 65 號提案的物質



接觸鉛會導致癌症和生殖危害。接觸鎳會導致癌症。

<https://www.P65Warnings.ca.gov/>

#### 不含衝突礦物

本產品不含來自剛果民主共和國或鄰近國家的任何被指定為“衝突礦物”的物質，例如鈿、錫、金或鎢。