

高度調整元件 · 定位

EH 25120.



產品描述

用於在軸承表面不平行時調平機器和裝置。
對於垂直調節，自鎖式高度調節元件配有細牙螺紋。所有元件都有一個用於緊固目的的通孔。轉向鎖用作最大調節高度的高度限制。

材質

- 熱處理鋼，鍍鋅，鉻化

圖面

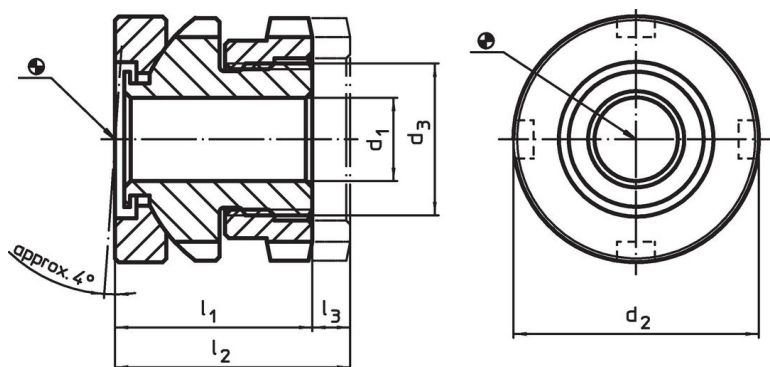



訂單資訊

d ₁	d ₂	尺寸 d ₃ [mm]	l ₁ ~	l ₂ ~	行程 l ₃ ~ [mm]	螺絲用 [mm]	靜態荷 重能力 max. [kN]	荷重能力 ¹⁾ max. [kN]	 [g]	品號
6,6	25	M15 x 1	22	26	4	M 6	40	30,7	66	25120.0206
6,6	32	M20 x 1	26	31	5	M 6	65	55,7	131	25120.0212
9,0	32	M20 x 1	26	31	5	M 8	65	48,0	124	25120.0214
11,0	32	M20 x 1	26	31	5	M10	65	37,9	117	25120.0216
11,0	45	M30 x 1,5	34	41	7	M10	120	92,9	340	25120.0222
13,5	45	M30 x 1,5	34	41	7	M12	120	80,4	320	25120.0224
17,5	45	M30 x 1,5	34	41	7	M16	120	45,5	324	25120.0226
17,5	58	M40 x 1,5	44	53	9	M16	210	136,0	775	25120.0232
22,0	58	M40 x 1,5	44	53	9	M20	210	90,0	641	25120.0234
26,0	58	M40 x 1,5	44	53	9	M24	210	37,0	683	25120.0236
22,0	70	M50 x 1,5	50	60	10	M20	330	210,0	1157	25120.0242
26,0	70	M50 x 1,5	50	60	10	M24	330	157,0	1114	25120.0244
33,0	70	M50 x 1,5	50	60	10	M30	330	53,0	990	25120.0246

¹⁾ Load capacity after deduction of the maximum preload force for screws 8.8.

配件

	適用於高度調整元件 尺寸 d ₂ [mm]	鑷刀型螺絲扳手尺寸 DIN 1810, 型式A [mm]	 [g]	品號
用於垂直調整的鑷刀形扳手				
	25	25 – 28	45	25120.0981
	32	30 – 32	46	25120.0982
	45	45 – 50	156	25120.0983
	58	58 – 62	250	25120.0984
	70	68 – 75	253	25120.0985

應用範例

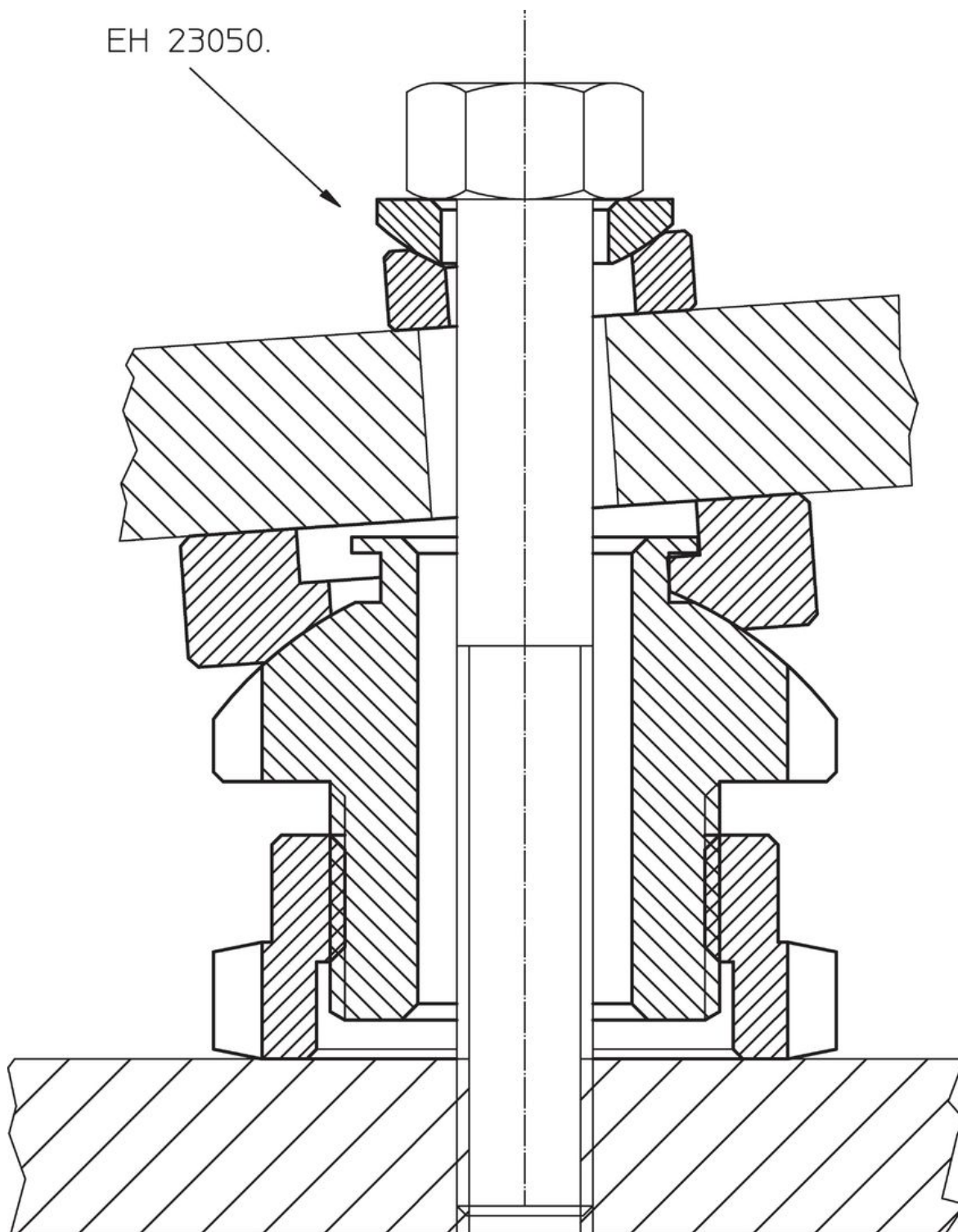

遵守

有關詳細的合規信息，請選擇所需的貨號。