

高度調整元件 · 高 EH 25120.



產品描述

對於機器和設備的流平性。
對於垂直調節，自鎖式高度調節元件配有細牙螺紋。所有元件都有一個用於緊固目的的通孔。轉向鎖用作最大調節高度的高度限制。

材質

- 熱處理鋼，鍍鋅，鉻化

圖面

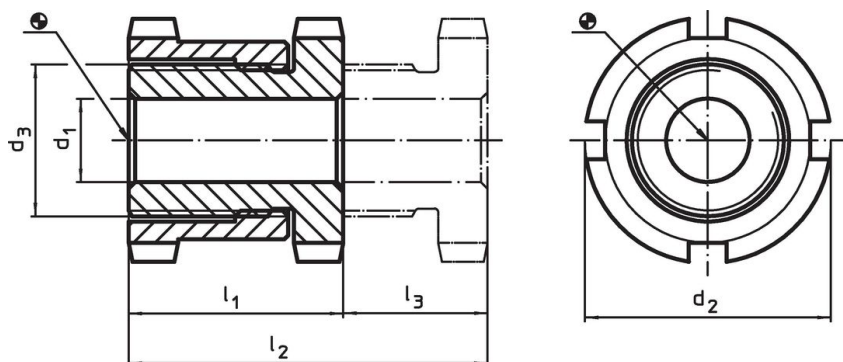



訂單資訊

d ₁	d ₂	尺寸 d ₃ [mm]	l ₁ ~	l ₂ ~	行程 l ₃ ~ [mm]	螺絲用 [mm]	靜態荷 重能力 max. [kN]	荷重能力 ¹⁾ max. [kN]	 [g]	品號
6,6	25	M15 x 1	28	43	15	M 6	40	30,7	68	25120.0106
6,6	32	M20 x 1	35	55	20	M 6	65	55,7	161	25120.0112
9,0	32	M20 x 1	35	55	20	M 8	65	48,0	152	25120.0114
11,0	32	M20 x 1	35	55	20	M10	65	37,9	142	25120.0116
11,0	45	M30 x 1,5	42	67	25	M10	120	92,9	371	25120.0122
13,5	45	M30 x 1,5	42	67	25	M12	120	80,4	356	25120.0124
17,5	45	M30 x 1,5	42	67	25	M16	120	45,5	326	25120.0126
17,5	58	M40 x 1,5	54	86	32	M16	210	136,0	835	25120.0132
22,0	58	M40 x 1,5	54	86	32	M20	210	90,0	771	25120.0134
26,0	58	M40 x 1,5	54	86	32	M24	210	37,0	705	25120.0136
22,0	70	M50 x 1,5	66	106	40	M20	330	210,0	1421	25120.0142
26,0	70	M50 x 1,5	66	106	40	M24	330	157,0	1329	25120.0144
33,0	70	M50 x 1,5	66	106	40	M30	330	53,0	1167	25120.0146

¹⁾ Load capacity after deduction of the maximum preload force for screws 8.8.

配件

	適用於高度調整元件 尺寸 d_2 [mm]	鑷刀型螺絲扳手尺寸 DIN 1810, 型式A [mm]	 [g]	品號
用於垂直調整的鑷刀形板手				
	25	25 – 28	45	25120.0981
	32	30 – 32	46	25120.0982
	45	45 – 50	156	25120.0983
	58	58 – 62	250	25120.0984
	70	68 – 75	253	25120.0985

應用範例

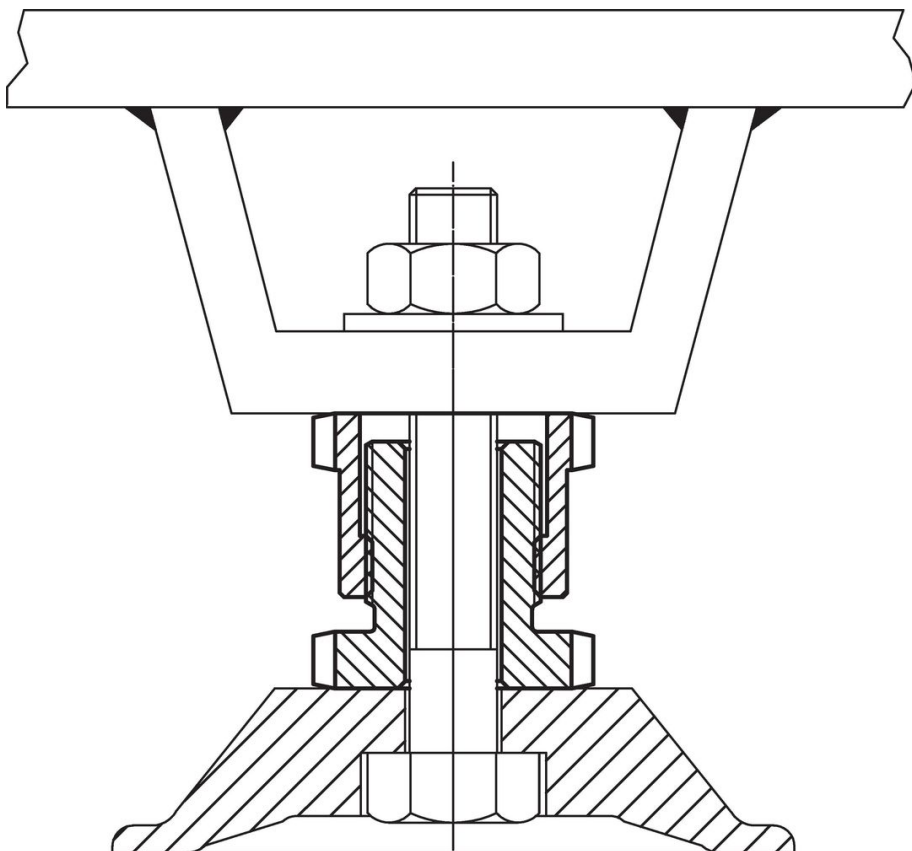

遵守

有關詳細的合規信息，請選擇所需的貨號。