

壓花螺帽·塑膠

EH 24820.



產品描述

材質

襯套

- 鋼，鍍鋅
- 不銹鋼 1.4305

把手

- 熱可塑性塑膠(PA)，黑色

圖面

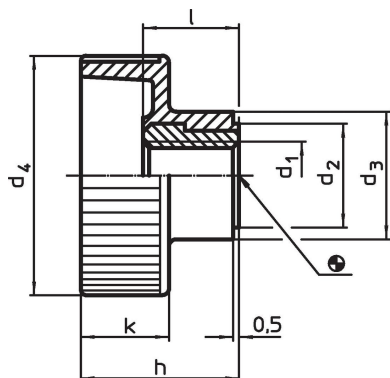

訂單資訊

				尺寸			溫度		重量 [g]	品號
d ₁	d ₂	d ₃	d ₄	h [mm]	k	l	min	max.		
鋼										
M 4	9	12	19	14,0	8,0	9,0	-30	80	4,5	24820.0004
M 5	9	12	19	14,0	8,0	9,0	-30	80	4,0	24820.0005
M 6	12	14	24	16,5	9,5	10,5	-30	80	7,0	24820.0006
M 8	14	16	30	19,5	11,0	11,5	-30	80	10,0	24820.0008
M10	16	18	36	22,5	12,5	14,0	-30	80	15,0	24820.0010
不銹鋼										
M 5	9	12	19	14,0	8,0	9,0	-30	80	4,0	24820.0205
M 6	12	14	24	16,5	9,5	10,5	-30	80	7,0	24820.0206
M 8	14	16	30	19,5	11,0	11,5	-30	80	10,0	24820.0208

應用範例

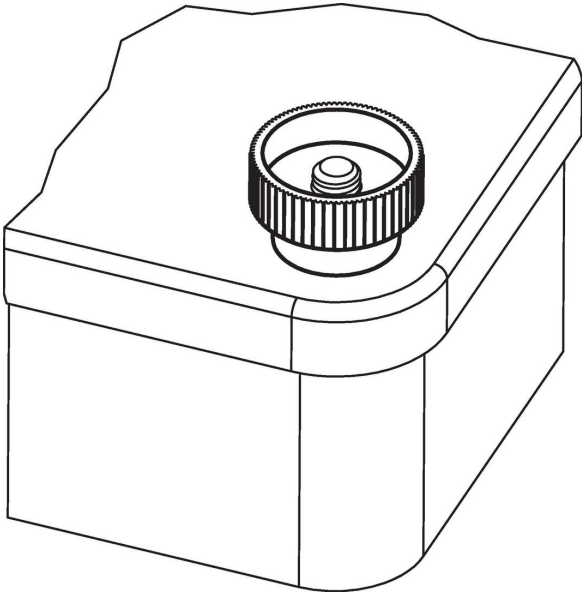

遵守

有關詳細的合規信息，請選擇所需的貨號。