

## 圓盤式手輪 · 輕合金

### EH 24600.



#### 產品描述

有握把凹槽在後側。  
對於所有的手輪，其輪殼經切銷而成，鋼圈經由車削，所有面經過鏡面加工處理。不切銷的表面則噴砂處理。跟鋼圈一起鏡面拋光，因此在大多數情況下，此手輪不需要額外的烤漆。

#### 材質

長柄大槌零件

- 鋼，鍍鋅

手輪

- 鋁永久模鑄造

圓柱形把手 EH 24530

- DIN 7708 - 熱固性塑膠 (PF 31)，黑色 (接近色號 RAL 9005)

#### 組裝

軸端華司 EH 22270。用於軸向緊固。

#### 更多資訊

#### 更多產品

- 軸端華司
- 圓柱形把手，旋轉

#### 圖面

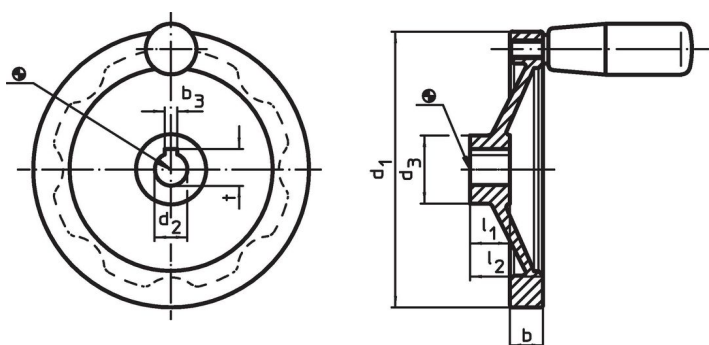

輪殼鍵槽的方向可能與圖中所示的不同。

#### 訂單資訊

尺寸						中心鍵槽 DIN 6885 規格表 1		一致。cyl.把手 EH 24530.	🌡️	🏷️	品號
d <sub>1</sub>	d <sub>2</sub> H7	d <sub>3</sub>	b	l <sub>1</sub>	l <sub>2</sub> ~	b <sub>3</sub>	t	[mm]	max.	[g]	
[mm]						[mm]		[mm]	[°C]		
<b>無輪殼鍵槽，無圓柱形手柄</b>											
80	10	26	13,0	16	26	-	-	-	-	121	24600.0000
80	12	26	13,0	16	26	-	-	-	-	139	24600.0001
100	10	28	14,0	17	30	-	-	-	-	203	24600.0005
100	12	28	14,0	17	30	-	-	-	-	205	24600.0006
125	12	31	15,0	18	33	-	-	-	-	307	24600.0010
125	14	31	15,0	18	33	-	-	-	-	298	24600.0011
140	14	36	16,5	19	36	-	-	-	-	430	24600.0015
140	16	36	16,5	19	36	-	-	-	-	417	24600.0016
160	14	36	18,0	20	39	-	-	-	-	540	24600.0020
160	16	36	18,0	20	39	-	-	-	-	533	24600.0021
200	18	42	20,5	24	45	-	-	-	-	849	24600.0030
200	20	42	20,5	24	45	-	-	-	-	866	24600.0031
250	22	48	23,0	28	51	-	-	-	-	1495	24600.0040
250	26	48	23,0	28	51	-	-	-	-	1441	24600.0041
<b>有輪殼鍵槽，無圓柱形把手</b>											
80	10	26	13,0	16	26	3	11,4	-	-	139	24600.0100
80	12	26	13,0	16	26	4	13,8	-	-	128	24600.0101
100	10	28	14,0	17	30	3	11,4	-	-	201	24600.0105
100	12	28	14,0	17	30	4	13,8	-	-	194	24600.0106
125	12	31	15,0	18	33	4	13,8	-	-	291	24600.0110
125	14	31	15,0	18	33	5	16,3	-	-	288	24600.0111
140	14	36	16,5	19	36	5	16,3	-	-	413	24600.0115
140	16	36	16,5	19	36	5	18,3	-	-	397	24600.0116

尺寸						中心鍵槽 DIN 6885 規格表 1		一致。cyl.把手 EH 24530.	max. [°C]	[g]	品號
d <sub>1</sub>	d <sub>2</sub> H7	d <sub>3</sub>	b	l <sub>1</sub>	l <sub>2</sub> ~	b <sub>3</sub>	t				
[mm]						[mm]		[mm]			
160	14	36	18,0	20	39	5	16,3	-	-	529	24600.0120
160	16	36	18,0	20	39	5	18,3	-	-	528	24600.0121
200	18	42	20,5	24	45	6	20,8	-	-	880	24600.0130
200	20	42	20,5	24	45	6	22,8	-	-	870	24600.0131
250	22	48	23,0	28	51	6	24,8	-	-	1515	24600.0140
250	26	48	23,0	28	51	8	29,3	-	-	1496	24600.0141
無輪穀鍵槽 含 圓柱 把手 EH 24530.											
80	10	26	13,0	16	26	-	-	18 x M 6	110	160	24600.0200
80	12	26	13,0	16	26	-	-	18 x M 6	110	160	24600.0201
100	10	28	14,0	17	30	-	-	21 x M 6	110	255	24600.0205
100	12	28	14,0	17	30	-	-	21 x M 6	110	255	24600.0206
125	12	31	15,0	18	33	-	-	23 x M 8	110	390	24600.0210
125	14	31	15,0	18	33	-	-	23 x M 8	110	390	24600.0211
140	14	36	16,5	19	36	-	-	23 x M 8	110	510	24600.0215
140	16	36	16,5	19	36	-	-	23 x M 8	110	510	24600.0216
160	14	36	18,0	20	39	-	-	26 x M10	110	675	24600.0220
160	16	36	18,0	20	39	-	-	26 x M10	110	675	24600.0221
200	18	42	20,5	24	45	-	-	26 x M10	110	995	24600.0230
200	20	42	20,5	24	45	-	-	26 x M10	110	995	24600.0231
250	22	48	23,0	28	51	-	-	28 x M10	110	1625	24600.0240
250	26	48	23,0	28	51	-	-	28 x M10	110	1625	24600.0241
有輪穀鍵槽 有圓柱形 把手 EH 24530.											
80	10	26	13,0	16	26	3	11,4	18 x M 6	110	160	24600.0300
80	12	26	13,0	16	26	4	13,8	18 x M 6	110	160	24600.0301
100	10	28	14,0	17	30	3	11,4	21 x M 6	110	255	24600.0305
100	12	28	14,0	17	30	4	13,8	21 x M 6	110	255	24600.0306
125	12	31	15,0	18	33	4	13,8	23 x M 8	110	390	24600.0310
125	14	31	15,0	18	33	5	16,3	23 x M 8	110	390	24600.0311
140	14	36	16,5	19	36	5	16,3	23 x M 8	110	510	24600.0315
140	16	36	16,5	19	36	5	18,3	23 x M 8	110	510	24600.0316
160	14	36	18,0	20	39	5	16,3	26 x M10	110	572	24600.0320
160	16	36	18,0	20	39	5	18,3	26 x M10	110	675	24600.0321
200	18	42	20,5	24	45	6	20,8	26 x M10	110	995	24600.0330
200	20	42	20,5	24	45	6	22,8	26 x M10	110	995	24600.0331
250	22	48	23,0	28	51	6	24,8	28 x M10	110	1625	24600.0340
250	26	48	23,0	28	51	8	29,3	28 x M10	110	1625	24600.0341

遵守

符合 RoHS

含鉛 - 相容除了例外 6a / 6b / 6c.

含有 >0.1% w/w 的 SVHC 物質

含鉛 - SVHC [REACH] 清單截至 2024 年 1 月 23 日

包含 65 號提案的物質



接觸鉛會導致癌症和生殖危害。接觸鎳會導致癌症。

<https://www.P65Warnings.ca.gov/>

不含衝突礦物

本產品不含來自剛果民主共和國或鄰近國家的任何被指定為“衝突礦物”的物質，例如鉭、錫、金或鎢。