

球形旋鈕 · DIN 319

EH 24560.



產品描述

DIN 319 球形把手是無縫，且經過拋光的。

材質

襯套

- 鋼，鍍鋅
- 黃銅

珠子

- 熱固性塑膠 (PF 31)，黑色 (接近色號 RAL 9005)
- 熱固塑料 PF 31，紅色 (接近色號 RAL 3003)

組裝

適用於型式 M 元件之組裝操作說明：
以鑿頭輕敲的方式安裝，固定於定位無須使用
固接劑。對於反作用元件而言，- h9-配合即已
足夠。

圖面

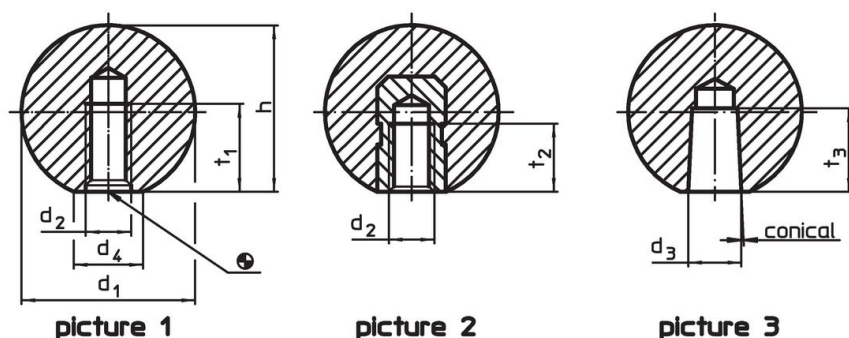

訂單資訊

| 尺寸 | | | | | | | | 雙頭螺栓用 h9 | 🌡️ max. | 📦 [g] | 品號 |
|------------------------|----------------|----------------|---------------------|--------|-----------------------|-----------------------|-----------------------|-------------|------------|----------|--------------------------|
| d ₁ | d ₂ | d ₃ | d ₄ ~ | h ~ | t ₁ min | t ₂ min | t ₃ min | [mm] | [°C] | [g] | |
| 有成形螺紋，型式 C – 相片 1, 黑色 | | | | | | | | | | | |
| 16 | M 4 | - | 8 | 15,0 | 7 | - | - | - | 110 | 3,2 | 24560.0016 |
| 20 | M 5 | - | 12 | 18,0 | 9 | - | - | - | 110 | 5,2 | 24560.0020 |
| 25 | M 6 | - | 15 | 22,5 | 11 | - | - | - | 110 | 10,0 | 24560.0025 |
| 32 | M 8 | - | 18 | 29,0 | 14 | - | - | - | 110 | 22,0 | 24560.0032 |
| 40 | M10 | - | 22 | 37,0 | 18 | - | - | - | 110 | 42,0 | 24560.0040 |
| 50 | M12 | - | 28 | 46,0 | 21 | - | - | - | 110 | 86,0 | 24560.0050 |
| 有螺紋的襯套，型式 E – 相片 2, 黑色 | | | | | | | | | | | |
| 16 | M 4 | - | 8 | 15,0 | - | 6,0 | - | - | 110 | 3,9 | 24560.0116 ¹⁾ |
| 20 | M 5 | - | 12 | 18,0 | - | 7,5 | - | - | 110 | 8,0 | 24560.0120 |
| 25 | M 6 | - | 15 | 22,5 | - | 9,0 | - | - | 110 | 14,0 | 24560.0125 |
| 32 | M 8 | - | 18 | 29,0 | - | 12,0 | - | - | 110 | 26,0 | 24560.0132 |
| 40 | M10 | - | 22 | 37,0 | - | 15,0 | - | - | 110 | 56,0 | 24560.0140 |
| 50 | M12 | - | 28 | 46,0 | - | 18,0 | - | - | 110 | 108,0 | 24560.0150 |
| 有成形螺紋，型式 C – 相片 1, 紅色 | | | | | | | | | | | |
| 16 | M 4 | - | 8 | 15,0 | 7 | - | - | - | 110 | 3,2 | 24560.0516 |
| 20 | M 5 | - | 12 | 18,0 | 9 | - | - | - | 110 | 5,2 | 24560.0520 |
| 25 | M 6 | - | 15 | 22,5 | 11 | - | - | - | 110 | 10,0 | 24560.0525 |
| 32 | M 8 | - | 18 | 29,0 | 14 | - | - | - | 110 | 22,0 | 24560.0532 |
| 40 | M10 | - | 22 | 37,0 | 18 | - | - | - | 110 | 42,0 | 24560.0540 |
| 50 | M12 | - | 28 | 46,0 | 21 | - | - | - | 110 | 86,0 | 24560.0550 |

¹⁾ 襯套從黃銅

| 尺寸 | | | | | | | | 雙頭螺栓用 | 🌡️ | 📦 | 品號 |
|------------------------|----------------|----------------|----------------|------|----------------|----------------|----------------|-------|------|-------|--------------------------|
| d ₁ | d ₂ | d ₃ | d ₄ | h | t ₁ | t ₂ | t ₃ | h9 | max. | [g] | |
| | | | | [mm] | min | min | min | [mm] | [°C] | | |
| 有螺紋的襯套，型式 E – 相片 2, 紅色 | | | | | | | | | | | |
| 16 | M 4 | – | 8 | 15,0 | – | 6,0 | – | – | 110 | 3,9 | 24560.0616 ¹⁾ |
| 20 | M 5 | – | 12 | 18,0 | – | 7,5 | – | – | 110 | 8,0 | 24560.0620 |
| 25 | M 6 | – | 15 | 22,5 | – | 9,0 | – | – | 110 | 14,0 | 24560.0625 |
| 32 | M 8 | – | 18 | 29,0 | – | 12,0 | – | – | 110 | 26,0 | 24560.0632 |
| 40 | M10 | – | 22 | 37,0 | – | 15,0 | – | – | 110 | 56,0 | 24560.0640 |
| 50 | M12 | – | 28 | 46,0 | – | 18,0 | – | – | 110 | 108,0 | 24560.0650 |
| 有斜度孔 型式 M – 相片 3, 黑色 | | | | | | | | | | | |
| 16 | – | 4 | 8 | 15,0 | – | – | 9 | 4 | 110 | 2,7 | 24560.0216 |
| 20 | – | 5 | 12 | 18,0 | – | – | 12 | 5 | 110 | 5,1 | 24560.0220 |
| 25 | – | 6 | 15 | 22,5 | – | – | 15 | 6 | 110 | 9,3 | 24560.0225 |
| 32 | – | 8 | 18 | 29,0 | – | – | 15 | 8 | 110 | 19,0 | 24560.0232 |
| 40 | – | 10 | 22 | 37,0 | – | – | 20 | 10 | 110 | 39,0 | 24560.0240 |
| 50 | – | 12 | 28 | 46,0 | – | – | 22 | 12 | 110 | 84,0 | 24560.0250 |

¹⁾ 襯套從黃銅

應用範例

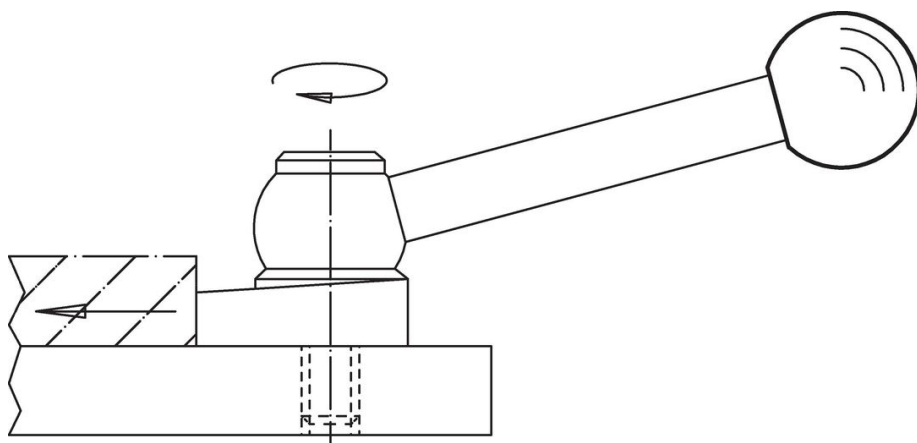

遵守

符合 RoHS

符合指令 2011/65/EU 和指令 2015/863

不含 SVHC 物質

不含超過 0.1% w/w 的 SVHC 物質 - 截至 2024 年 6 月 27 日的 SVHC 清單。

不含 65 號提案物質

不包括 65 號提案物質

<https://www.P65Warnings.ca.gov/>

不含衝突礦物

本產品不含來自剛果民主共和國或鄰近國家的任何被指定為“衝突礦物”的物質，例如鈮、錫、金或鎢。