

把手 · DIN 39
EH 24450.



產品描述

材質

- 鋼，車削，鍍鋅，鈍化
- 鍍鋅

圖面

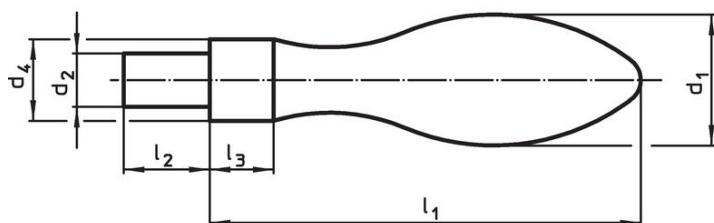

圖片 1

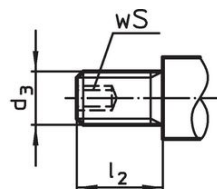

圖片 2

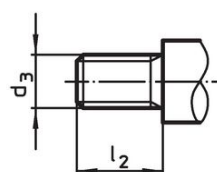

圖片 3

訂單資訊

d ₁	d ₂ h8	d ₃	尺寸 d ₄ h13 [mm]	l ₁ ~	l ₂	l ₃	WS [mm]	 [g]	品號
含平滑把手，型式 D - 相片 1, 鋼									
16	7	-	10	50	11	7	-	45	24450.0016
20	8	-	13	64	13	8	-	92	24450.0020
25	10	-	16	80	14	10	-	179	24450.0025
32	13	-	20	100	21	13	-	356	24450.0032
36	16	-	22	112	26	14	-	519	24450.0036
含公牙把手，型式 E - 相片 2, 鋼									
16	-	M 6	10	50	11	7	3	43	24450.0116
20	-	M 8	13	64	13	8	4	88	24450.0120
25	-	M10	16	80	14	10	5	175	24450.0125
32	-	M12	20	100	21	13	6	340	24450.0132
36	-	M16	22	112	26	14	8	509	24450.0136
含公牙把手，型式 E - 相片 3, 不銹鋼									
16	-	M 6	10	50	11	7	-	45	24450.0316
20	-	M 8	13	64	13	8	-	92	24450.0320
25	-	M10	16	80	14	10	-	186	24450.0325

應用範例

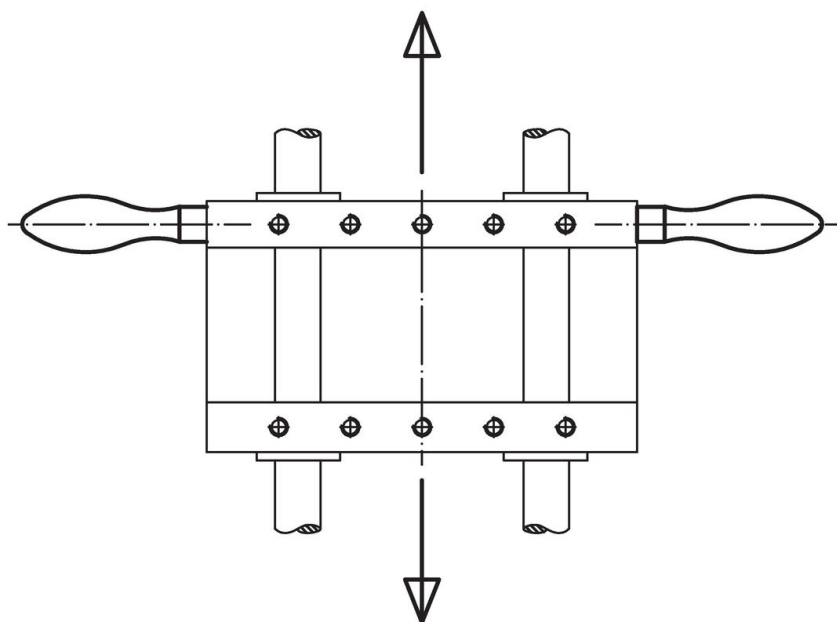

遵守

有關詳細的合規信息，請選擇所需的貨號。