

螺旋千斤頂 EH 23470.



產品描述

梯形自鎖式螺紋元件。含有最終安全裝置之心軸。支托元件這類可藉由T形槽加以固定的元件，可用以固定千斤頂，使其不致於在更換工件時滑離定位。此外，可用以將螺旋型千斤頂固定於垂直的固夾面上，而螺旋型千斤頂通常係用於工件的支撐。自我對準型蓋子的使用可確保支承面的正確對準。將對中定位板作為中間元件時，可將 52、70 及 100 等尺寸的螺旋型千斤頂上下固定在一起。

材質

自校調整蓋

- 鋼，表面硬化，染黑

托座

- 鋼，染黑

螺旋千斤頂

- 鋼1.0503亮漆



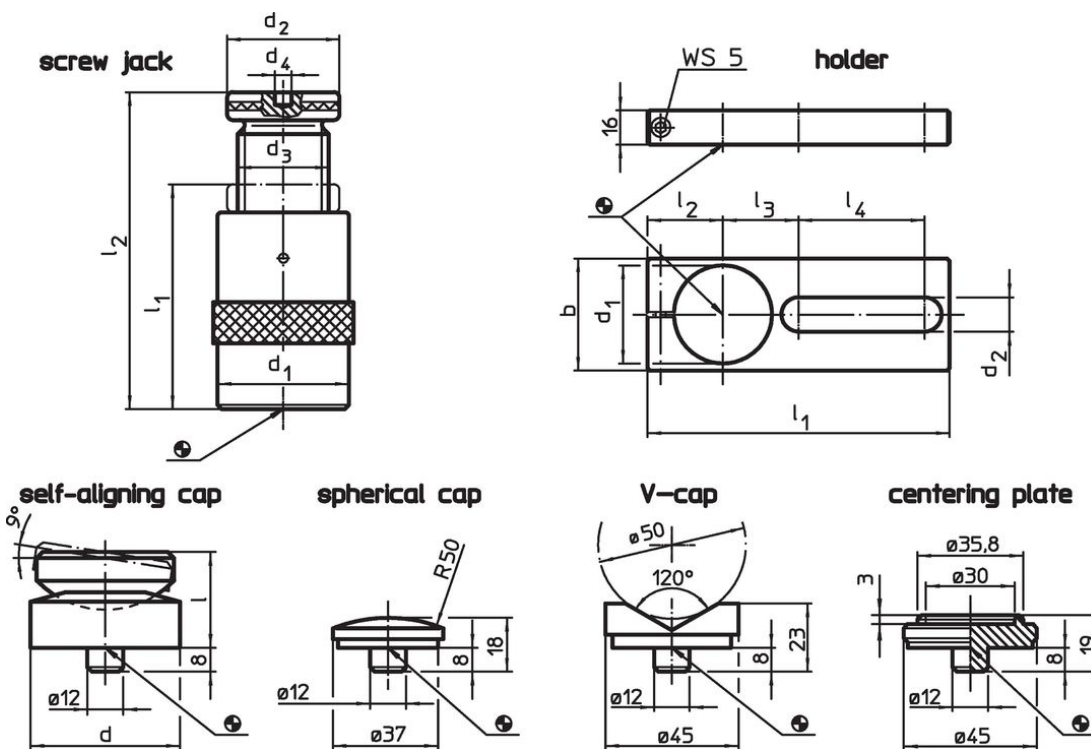



圖面



訂單資訊

l ₂ 夾持高度 max. [mm]	l ₁ min	尺寸				荷重能力 [kN]	[g]	品號
		d ₁ [mm]	d ₂	d ₃	d ₄ [mm]			
千斤頂								
50	38	31	31	Tr 20 x 4	-	15	191	23470.0005
52	42	50	50	Tr 30 x 4	12	60	539	23470.0006
70	50	50	50	Tr 30 x 4	12	60	645	23470.0007
100	70	50	50	Tr 30 x 4	12	60	900	23470.0010
140	100	69	69	Tr 40 x 7	12	100	2614	23470.0014
210	140	80	70	Tr 50 x 8	12	170	4336	23470.0021
300	190	100	80	Tr 65 x 10	12	350	9680	23470.0030

配件

	d	d ₁	b	d ₂	尺寸					螺絲千斤頂 [mm]	 [g]	品號
					l	l ₁	l ₂	l ₃	l ₄			
[mm]												
托座												
	-	31	40	18,5	-	175	30	35	90	50	516	23470.0232
	-	50	60	20,5	-	190	38	46	90	52/ 70/100	879	23470.0250
	-	69	80	24,5	-	210	48	54	90	140	1279	23470.0270
自行校準蓋												
	50	-	-	-	32	-	-	-	-	52/ 70/100	399	23470.0350
	65	-	-	-	35	-	-	-	-	140/210	716	23470.0365
球形蓋												
	-	-	-	-	-	-	-	-	-	52/ 70/100/140/210/300	75	23470.0171
V型蓋												
	-	-	-	-	-	-	-	-	-	52/ 70/100/140/210/300	138	23470.0172
中心板												
	-	-	-	-	-	-	-	-	-	52/ 70/100	107	23470.0170

遵守

有關詳細的合規信息，請選擇所需的貨號。