

垂直切換夾 · with horizontal base

EH 23330.



產品描述

由於它們具有良好的運動功率和易於操作的特性，肘節夾具適用於廣泛的用途。這些肘桿夾具可用於金屬加工行業，適用於鑽孔，焊接，折彎，研磨，測試和裝配，也可用於木材和塑料行業的膠合，鑽孔，切割和銼削夾具。

肘節式夾具的“肘節”原理允許夾具大而快地打開。如果夾具鬆開時，工件可不受阻礙的被取出。大功率傳動通過低手力產生最大夾持力。夾具是自鎖的，它們保持鎖定，抵抗加工部件時產生的力。

肘節式夾具由高質量的部件製成，設計用於連續使用。

耐油的符合人體工程學的雙組分手柄，抓握面積增加，表面柔軟，易於使用。

快速可調的夾緊螺釘由保持器提供。

材質

夾具
• 鋼，鍍鋅，鈍化
• 不銹鋼

鉚釘
• 不銹鋼
• 鋼

把手
• 塑膠

夾持螺絲
• 鋼，回火，鍍鋅
• 不銹鋼

緊固帽蓋
• 橡膠，黑色

更多資訊

參考

作為配件的替換夾合螺絲，在網路商店上有提供。

圖面

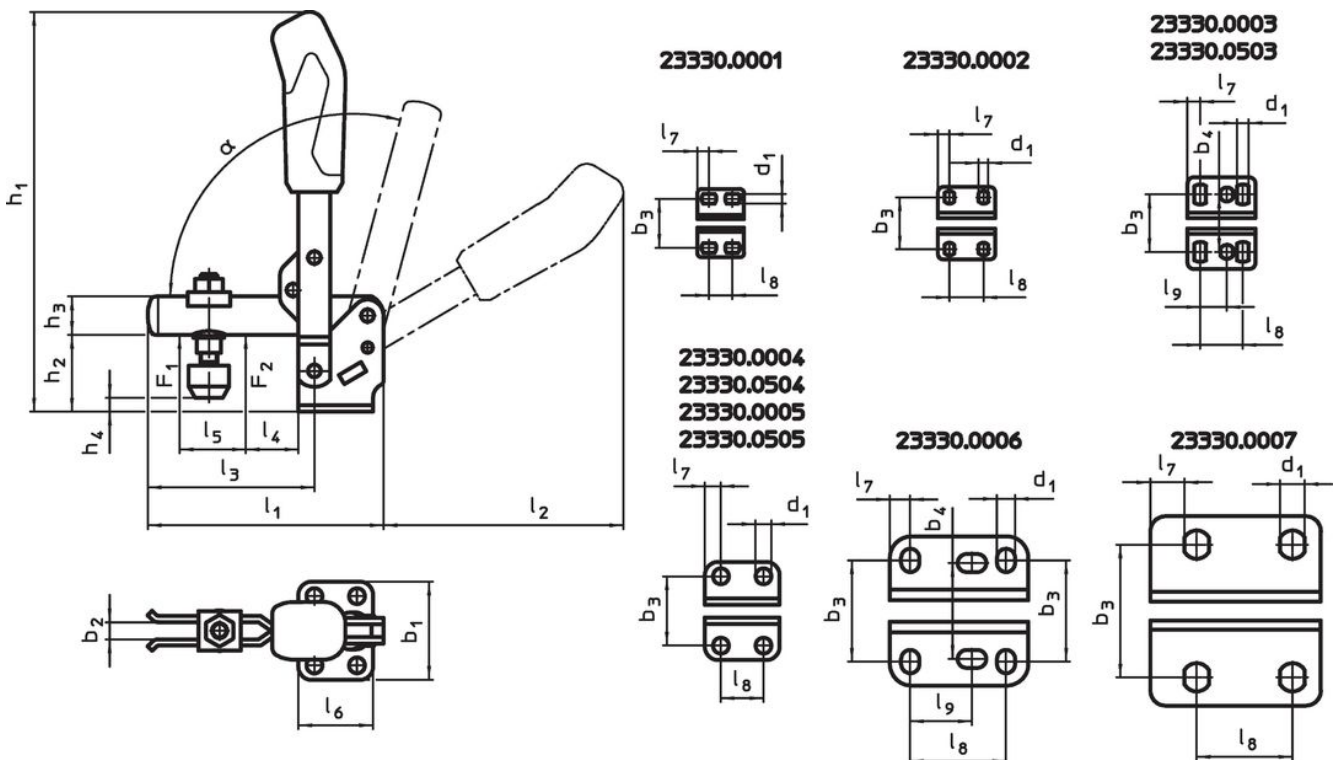



訂單資訊

公稱 尺寸	夾持螺絲 [mm]	尺寸																		夾持力		α	minmax [°C]	 [g]	品號		
		d ₁	b ₁	b ₂	b ₃	b ₄	h ₁	h ₂	h ₃	h ₄ min	h ₄ max.	l ₁	l ₂	l ₃	l ₄	l ₅	l ₆	l ₇	l ₈	l ₉	F ₁					F ₂	[kN]
鋼																											
1	M 4 x 25	4,5	32	4	23,0	-	81,0	18,0	8	-1,5	3,5	49	50	31,0	5,5	14	22	5,5	8,5 - 13,5	-	0,5	0,7	95°	-10	80	66	23330.0001
2	M 5 x 30	4,5	34	5	22,5 - 26,0	-	98,5	19,0	10	-4,0	2,0	61	59	39,0	6,0	18	27	5,5	16,0	-	0,6	1,1	95°	-10	80	114	23330.0002
3	M 6 x 35	5,5	43	6	23,0 - 31,0	27	129,0	23,0	12	-3,0	4,5	78	80	52,0	11,0	25	32	6,0	20,0	12,5	0,8	1,2	105° ¹⁾	-10	80	192	23330.0003
4	M 8 x 45	7,5	46	8	32,5	-	186,0	33,0	18	2,0	11,0	112	112	79,0	19,0	37	35	7,5	20,0	-	1,2	2,5	105° ¹⁾	-10	80	410	23330.0004
5	M 8 x 65	8,6	64	10	43,5 - 46,5	-	221,0	42,5	20	-6,0	22,5	141	130	101,0	16,0	54	53	13,0	32,0	-	1,7	3,0	105° ¹⁾	-10	80	687	23330.0005
6	M12 x 80	8,5	70	14	45,0 - 50,0	45	281,0	55,8	25	-3,0	27,5	195	185	140,0	34,0	73	65	9,5	45,0	26,5 - 31,5	3,0	5,0	115° ¹⁾	-10	80	1492	23330.0006
7	M12 x 110	13,0	100	14	37,5 - 72,5	-	333,0	81,0	30	-2,5	55,0	231	206	165,5	28,0	89	90	24,5	50,5	-	3,4	5,5	140° ¹⁾	-10	80	2000	23330.0007
不銹鋼																											
3	M 6 x 35	5,5	43	6	23,0 - 31,0	27	129,0	23,0	12	-3,0	4,5	78	80	52,0	11,0	25	32	6,0	20,0	12,5	0,8	1,2	105° ¹⁾	-10	80	195	23330.0503
4	M 8 x 45	7,5	46	8	32,5	-	186,0	33,0	18	2,0	11,0	112	112	79,0	19,0	37	35	7,5	20,0	-	1,2	2,5	105° ¹⁾	-10	80	430	23330.0504
5	M 8 x 65	8,6	64	10	43,5 - 46,5	-	221,0	42,5	20	-6,0	22,5	141	130	101,0	16,0	54	53	13,0	32,0	-	1,7	3,0	105° ¹⁾	-10	80	697	23330.0505

¹⁾ 通過按壓止動銷可將手柄的開啟角度改為60°。

配件

	尺寸 d ₂ [mm]	 [g]	品號
夾緊螺釘 (肘節夾的備件), 鋼			
	M 4 x 25	6,2	23330.9001
	M 5 x 30	11,0	23330.9002
	M 6 x 35	16,0	23330.9003
	M 8 x 45	38,0	23330.9005
	M 8 x 65	57,0	23330.9006
	M12 x 80	147,0	23330.9007
	M12 x 110	170,0	23330.9008
夾緊螺釘 (肘節夾的備件), 不鏽鋼			
	M 6 x 35	16,0	23330.9503
	M 8 x 45	38,0	23330.9504
	M 8 x 65	57,0	23330.9505

應用範例

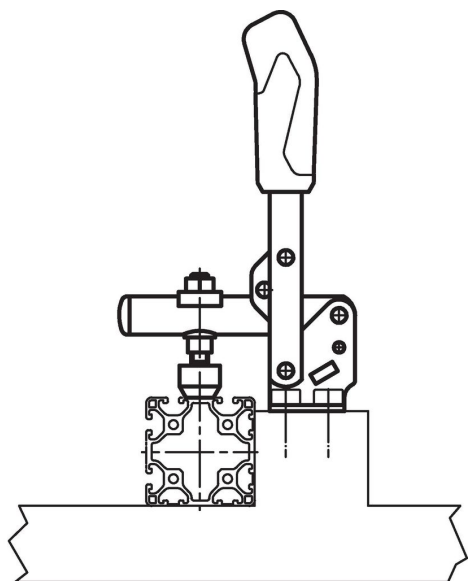

遵守

有關詳細的合規信息，請選擇所需的貨號。