

定位珠螺絲·有頭 EH 22710.



產品描述

球頭推力螺釘還可用於定位和夾緊、緊固或支撐非平行表面。

材質

珠子

- 軸承鋼，硬化
- 不鏽鋼，硬化

螺絲

- 鋼，熱處理， $1200 \pm 100 \text{ N/mm}^2$
- 不鏽鋼 1.4305

更多資訊

注意事項

特殊的樣式歡迎洽詢。

參考

螺紋鎖附依需求，請參閱附錄 - 技術數據 -

圖面

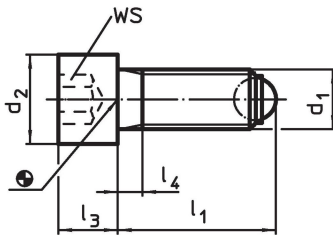

訂單資訊

d ₁	l ₁ ~	尺寸			球直徑	WS [mm]	靜態荷重能力 ¹⁾ max. [kN]	[g]	品號
		d ₂	l ₃	l ₄					
圓珠子，鋼或不鏽鋼鋼(相片1), 熱處理鋼									
M 6	20,8	10	6	3,0	4,0	5	9	6,1	22710.0062
M 6	30,8	10	6	3,0	4,0	5	9	7,9	22710.0064
M 6	40,8	10	6	16,0	4,0	5	9	9,9	22710.0066
M 8	21,2	13	8	3,5	5,5	6	15	13,0	22710.0082
M 8	36,2	13	8	3,5	5,5	6	15	17,0	22710.0084
M 8	51,2	13	8	22,0	5,5	6	15	23,0	22710.0086
M10	26,7	16	10	4,5	7,0	8	20	24,0	22710.0102
M10	41,7	16	10	4,5	7,0	8	20	32,0	22710.0104
M10	61,7	16	10	28,0	7,0	8	20	44,0	22710.0106
M12	32,0	18	12	5,0	8,5	10	30	39,0	22710.0122
M12	52,0	18	12	5,0	8,5	10	30	52,0	22710.0124
M12	82,0	18	12	44,0	8,5	10	30	80,0	22710.0126
M16	43,3	24	16	6,0	12,0	14	60	94,0	22710.0162
M16	63,3	24	16	6,0	12,0	14	60	122,0	22710.0164
M16	83,3	24	16	36,0	12,0	14	60	154,0	22710.0166
M20	54,2	30	20	7,5	15,0	17	90	186,0	22710.0202
M20	84,2	30	20	28,0	15,0	17	90	255,0	22710.0204
M20	104,2	30	20	48,0	15,0	17	90	306,0	22710.0206
M24	64,7	36	24	9,0	18,0	19	120	327,0	22710.0242
M24	94,7	36	24	30,0	18,0	19	120	428,0	22710.0244
M24	124,7	36	24	60,0	18,0	19	120	532,0	22710.0246
圓珠子，鋼或不鏽鋼鋼(相片1), 不銹鋼									
M 6	20,8	10	6	3,0	4,0	5	9	6,1	22710.0752
M 6	30,8	10	6	3,0	4,0	5	9	7,9	22710.0754
M 6	40,8	10	6	16,0	4,0	5	9	9,9	22710.0756
M 8	21,2	13	8	3,5	5,5	6	15	13,0	22710.0762
M 8	36,2	13	8	3,5	5,5	6	15	17,0	22710.0764
M 8	51,2	13	8	22,0	5,5	6	15	23,0	22710.0766
M10	26,7	16	10	4,5	7,0	8	20	24,0	22710.0772

¹⁾ 荷重能力報告書不適用於不銹鋼

d ₁	l ₁ ~	尺寸				球直徑	WS [mm]	靜態荷重能力 ¹⁾ max. [kN]	 [g]	品號
		d ₂	l ₃	l ₄	[mm]					
M10	41,7	16	10	4,5	7,0	8	20	32,0	22710.0774	
M10	61,7	16	10	28,0	7,0	8	20	44,0	22710.0776	
M12	32,0	18	12	5,0	8,5	10	30	39,0	22710.0782	
M12	52,0	18	12	5,0	8,5	10	30	52,0	22710.0784	
M12	82,0	18	12	44,0	8,5	10	30	80,0	22710.0786	
M16	43,3	24	16	6,0	12,0	14	60	94,0	22710.0792	
M16	63,3	24	16	6,0	12,0	14	60	122,0	22710.0794	
M16	83,3	24	16	36,0	12,0	14	60	154,0	22710.0796	

¹⁾*荷重能力報告書不適用於不銹鋼

應用範例

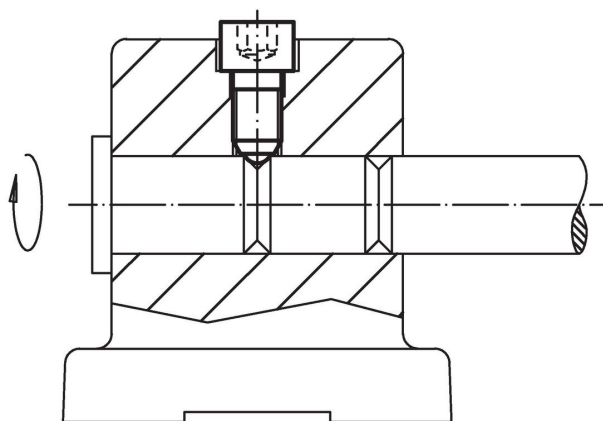

遵守

符合 RoHS

符合指令 2011/65/EU 和指令 2015/863

不含 SVHC 物質

不含超過 0.1% w/w 的 SVHC 物質 - 截至 2024 年 1 月 23 日的 SVHC 清單。

不含 65 號提案物質

不包括 65 號提案物質

<https://www.P65Warnings.ca.gov/>

不含衝突礦物

本產品不含來自剛果民主共和國或鄰近國家的任何被指定為“衝突礦物”的物質，例如鉭、錫、金或鎳。