

## 分割定位柱 · 帶六角環和鎖定，不銹鋼 A4 EH 22120.



### 產品描述

索引柱塞用於索引鑽孔。  
不銹鋼 A4 版本確保最大的耐腐蝕性。

### 材質

- 本體
- 不銹鋼 1.4401
- 固定梢子
- 不銹鋼 1.4401 鍍鍍
- 手把
- 熱塑性 PA 6，黑灰色，無光澤
  - 不銹鋼 1.4401
- 固定螺帽
- 不銹鋼 1.4401

### 更多資訊

#### 注意事項

不可移動的旋鈕。  
螺帽必須個別購買。

### 圖面

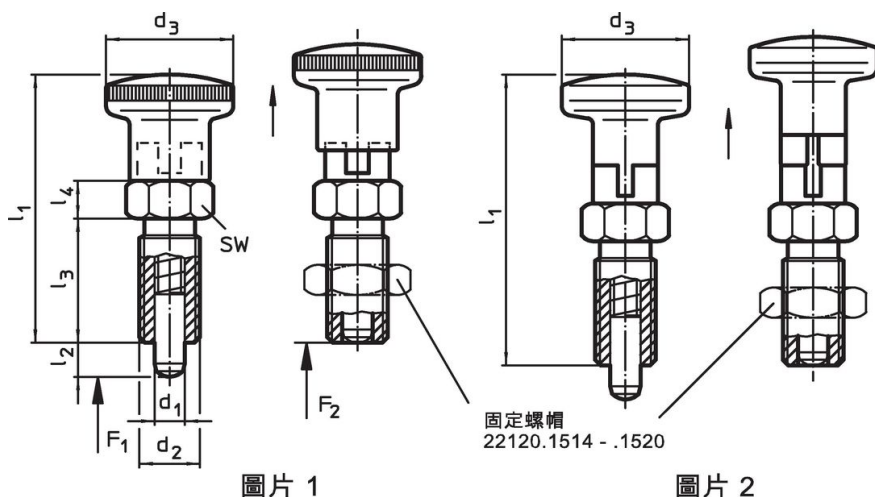

圖片 1

圖片 2

### 訂單資訊

尺寸							彈簧荷重 <sup>1)</sup>		溫度		重量 [g]	品號	
d <sub>1</sub>	d <sub>2</sub>	l <sub>2</sub> min	d <sub>3</sub>	l <sub>1</sub>	l <sub>3</sub>	l <sub>4</sub>	F <sub>1</sub> ~	F <sub>2</sub> ~	min	max.			
[mm]							[N]		[°C]		[g]		
-0,02													
-0,05													
帶熱塑性塑料旋鈕 – 相片 1													
4	M 8 x 1	4	16	35,0	16	5	3,5	11	-30	80	12	22120.1144	
4	M 8 x 1	6	16	35,0	22	6	4,5	16	-30	80	11	22120.1164	
5	M10 x 1	5	19	35,0	16	5	3,0	11	-30	80	20	22120.1145	
5	M10 x 1	8	19	48,0	22	6	4,0	20	-30	80	18	22120.1165	
6	M12 x 1,5	6	23	40,0	18	6	3,0	12	-30	80	33	22120.1146	
6	M12 x 1,5	9	23	58,0	26	8	6,0	23	-30	80	33	22120.1166	
8	M16 x 1,5	8	28	58,0	26	8	7,0	26	-30	80	67	22120.1168	
8	M16 x 1,5	12	28	40,0	18	6	3,0	14	-30	80	70	22120.1148	
10	M16 x 1,5	12	28	58,0	26	8	7,5	32	-30	80	70	22120.1180	
12	M20 x 1,5	15	33	71,5	33	10	9,0	32	-30	80	141	22120.1182	
帶不銹鋼旋鈕 – 相片 2													
4	M 8 x 1	4	16	35,0	16	5	3,5	11	-	100	21	22120.1154	
4	M 8 x 1	6	16	35,0	16	5	3,0	11	-	100	22	22120.1174	
5	M10 x 1	5	18	40,0	18	6	3,0	12	-	100	36	22120.1155	
5	M10 x 1	8	18	40,0	18	6	3,0	14	-	100	37	22120.1175	

<sup>1)</sup> 統計平均值

d <sub>1</sub> -0,02 -0,05	d <sub>2</sub>	尺寸					彈簧荷重 <sup>1)</sup>		溫度		重量 [g]	品號	
		l <sub>2</sub> min	d <sub>3</sub>	l <sub>1</sub>	l <sub>3</sub>	l <sub>4</sub>	F <sub>1</sub> ~ [N]	F <sub>2</sub> ~ [N]	min	max.			
[mm]												[°C]	[g]
6	M12 x 1,5	6	22	48,0	22	6	4,5	16	-	100	60	<a href="#">22120.1156</a>	
6	M12 x 1,5	9	22	48,0	22	6	4,0	20	-	100	63	<a href="#">22120.1176</a>	
8	M16 x 1,5	8	27	58,0	26	8	6,0	23	-	100	117	<a href="#">22120.1178</a>	
8	M16 x 1,5	12	27	58,0	26	8	7,0	26	-	100	118	<a href="#">22120.1158</a>	
10	M16 x 1,5	12	27	58,0	26	8	7,5	32	-	100	135	<a href="#">22120.1190</a>	
12	M20 x 1,5	15	32	71,5	33	10	9,0	32	-	100	229	<a href="#">22120.1192</a>	

<sup>1)</sup> 統計平均值

## 配件

鎖緊螺母	尺寸	扳手尺寸	重量	品號
	d <sub>2</sub> [mm]	[mm]	[g]	
鎖緊螺母 ISO 8675 (DIN 439), 不銹鋼 1.4401				
	M 8 x 1	13	2,8	<a href="#">22120.1514</a>
	M12 x 1,5	18	7,6	<a href="#">22120.1516</a>
	M10 x 1	16	5,4	<a href="#">22120.1515</a>
	M16 x 1,5	24	18,0	<a href="#">22120.1518</a>
	M20 x 1,5	30	33,0	<a href="#">22120.1520</a>

## 遵守

有關詳細的合規信息，請選擇所需的貨號。