

分割螺栓 EH 22120.



產品描述

索引螺栓用於索引
塑膠把手有較佳的握緊觸感。

材質

本體

- 切削鋼， 染黑
- 不鏽鋼 1.4305

固定梢子

- 鋼， 硬化
- 不銹鋼 1.4305， 鍍線

扣住

- 切削鋼， 染黑
- 乾燥的粉末金屬 1.4404

塑膠蓋

- 熱塑性的， 黑色， 無光澤的

操作

藉由旋轉分割螺栓 180°， 銷子將會縮回並被固定在凹槽處 (此時銷子不會彈出)。

更多資訊

注意事項

螺帽必須個別購買。

更多產品

- 支持座, 用於分割螺栓和分割定位柱, 壓鑄
- 定位襯套, 適用於分割螺栓和分割定位柱
- 支持座, 適用於分割螺栓和分割定位柱

圖面

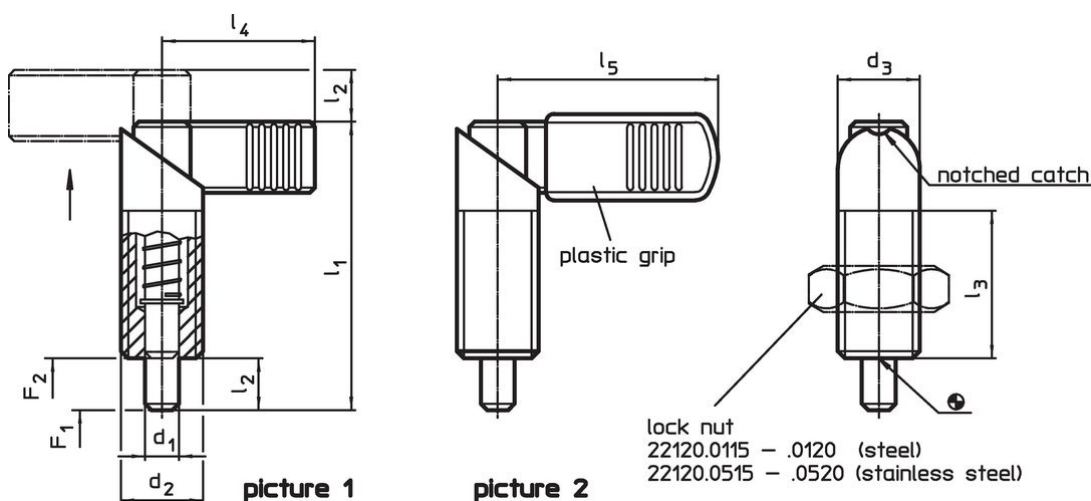

訂單資訊

尺寸			尺寸					彈簧荷重 ¹⁾		溫度		重量	品號
d ₁	d ₂	d ₃	l ₁	l ₂	l ₃	l ₄	l ₅	F ₁	F ₂	min	max.	[g]	
-0,02 -0,04								~	~				
[mm]													
[N]													
[°C]													
把手無塑膠披覆 - 相片 1, 易削切鋼													
4	M10 x 1	10	37,5	6	19	21	-	7,0	20,0	-	250	17	22120.0302
5	M10 x 1	10	37,5	6	19	21	-	7,0	20,0	-	250	18	22120.0304
6	M10 x 1	10	37,5	6	19	21	-	7,0	20,0	-	250	18	22120.0306
5	M12 x 1,5	12	47,0	8	26	26	-	8,5	19,5	-	250	29	22120.0313
6	M12 x 1,5	12	47,0	8	26	26	-	8,5	19,5	-	250	29	22120.0314
6	M16 x 1,5	16	56,0	10	30	32	-	11,5	30,5	-	250	75	22120.0316
8	M12 x 1,5	12	47,0	8	26	26	-	8,5	19,5	-	250	30	22120.0315
8	M16 x 1,5	16	56,0	10	30	32	-	11,5	30,5	-	250	61	22120.0317
8	M20 x 1,5	20	69,0	12	36	37	-	21,0	57,5	-	250	121	22120.0318
10	M16 x 1,5	16	56,0	10	30	32	-	11,5	30,5	-	250	64	22120.0319
10	M20 x 1,5	20	69,0	12	36	37	-	21,0	57,5	-	250	128	22120.0320
12	M20 x 1,5	20	69,0	12	36	37	-	21,0	57,5	-	250	127	22120.0322

¹⁾ 統計平均值

d ₁ -0,02 -0,04	d ₂	d ₃	尺寸					彈簧荷重 ¹⁾		min max.	[°C]	[g]	品號
			l ₁	l ₂	l ₃	l ₄	l ₅	F ₁ ~	F ₂ ~				
			[mm]					[N]					
把手無塑膠披覆 – 相片 1, 不銹鋼													
4	M10 x 1	10	37,5	6	19	21	–	7,0	20,0	–	250	17	22120.0308
5	M10 x 1	10	37,5	6	19	21	–	7,0	20,0	–	250	18	22120.0310
6	M10 x 1	10	37,5	6	19	21	–	7,0	20,0	–	250	18	22120.0312
5	M12 x 1,5	12	47,0	8	26	26	–	8,5	19,5	–	250	29	22120.0323
6	M12 x 1,5	12	47,0	8	26	26	–	8,5	19,5	–	250	29	22120.0324
6	M16 x 1,5	16	56,0	10	30	32	–	11,5	30,5	–	250	75	22120.0326
8	M12 x 1,5	12	47,0	8	26	26	–	8,5	19,5	–	250	30	22120.0325
8	M16 x 1,5	16	56,0	10	30	32	–	11,5	30,5	–	250	61	22120.0327
8	M20 x 1,5	20	69,0	12	36	37	–	21,0	57,5	–	250	121	22120.0328
10	M16 x 1,5	16	56,0	10	30	32	–	11,5	30,5	–	250	64	22120.0329
10	M20 x 1,5	20	69,0	12	36	37	–	21,0	57,5	–	250	128	22120.0330
12	M20 x 1,5	20	69,0	12	36	37	–	21,0	57,5	–	250	127	22120.0332
把手有塑膠披覆 – 相片 2, 易削切鋼													
5	M12 x 1,5	12	47,0	8	26	–	32	8,5	19,5	-30	80	30	22120.0353
6	M12 x 1,5	12	47,0	8	26	–	32	8,5	19,5	-30	80	30	22120.0354
6	M16 x 1,5	16	56,0	10	30	–	42	11,5	30,5	-30	80	61	22120.0356
8	M12 x 1,5	12	47,0	8	26	–	32	8,5	19,5	-30	80	32	22120.0355
8	M16 x 1,5	16	56,0	10	30	–	42	11,5	30,5	-30	80	63	22120.0357
8	M20 x 1,5	20	69,0	12	36	–	52	21,0	57,5	-30	80	124	22120.0358
10	M16 x 1,5	16	56,0	10	30	–	42	11,5	30,5	-30	80	66	22120.0359
10	M20 x 1,5	20	69,0	12	36	–	52	21,0	57,5	-30	80	128	22120.0360
12	M20 x 1,5	20	69,0	12	36	–	52	21,0	57,5	-30	80	131	22120.0362
把手有塑膠披覆 – 相片 2, 不銹鋼													
5	M12 x 1,5	12	47,0	8	26	–	32	8,5	19,5	-30	80	30	22120.0363
6	M12 x 1,5	12	47,0	8	26	–	32	8,5	19,5	-30	80	30	22120.0364
6	M16 x 1,5	16	56,0	10	30	–	42	11,5	30,5	-30	80	61	22120.0366
8	M12 x 1,5	12	47,0	8	26	–	32	8,5	19,5	-30	80	32	22120.0365
8	M16 x 1,5	16	56,0	10	30	–	42	11,5	30,5	-30	80	63	22120.0367
8	M20 x 1,5	20	69,0	12	36	–	52	21,0	57,5	-30	80	124	22120.0368
10	M16 x 1,5	16	56,0	10	30	–	42	11,5	30,5	-30	80	66	22120.0369
10	M20 x 1,5	20	69,0	12	36	–	52	21,0	57,5	-30	80	128	22120.0370
12	M20 x 1,5	20	69,0	12	36	–	52	21,0	57,5	-30	80	131	22120.0372

¹⁾ 統計平均值

配件

	尺寸 d ₂ [mm]	扳手尺寸 [mm]	[g]	品號
鎖緊螺母 ISO 8675 (DIN 439), 鋼				
	M10 x 1	16	5,2	22120.0115
	M12 x 1,5	18	7,5	22120.0116
	M16 x 1,5	24	15,0	22120.0118
	M20 x 1,5	30	32,0	22120.0120
鎖緊螺母 ISO 8675 (DIN 439), 不銹鋼				
	M10 x 1	16	5,2	22120.0515
	M12 x 1,5	18	7,5	22120.0516
	M16 x 1,5	24	15,0	22120.0518
	M20 x 1,5	30	32,0	22120.0520

遵守

有關詳細的合規信息，請選擇所需的貨號。