

分割定位柱精實的 · 有六角環和鎖固

EH 22110.



產品描述

索引柱塞用於索引鑽孔。
含鎖/不含鎖具有相同高度。
由於螺栓縮回,分割定位柱可以完全被鎖入。

材質

- 本體**
- 鋼, 染黑
 - 不鏽鋼 1.4305
- 固定梢子**
- 鋼, 硬化
 - 不銹鋼 1.4305, 鍍鎳
- 手把**
- 塑膠(PA6), 黑色, 無光澤的
 - 熱塑性塑膠 PA 6, 紅色, 暗淡

組裝

螺絲長度可由分割定位柱襯套調整 (EH 22120.)。

操作

旋鈕被拉出, 轉90度並由一個槽口夾住 (此時鎖銷不應突出)。

更多資訊

注意事項

不可移動的旋鈕。
螺帽必須個別購買。

更多產品

- 支持座, 用於分割螺栓和分割定位柱, 壓鑄
- 定位襯套, 適用於分割螺栓和分割定位柱
- 距離調整環, 適用於分割定位柱

圖面

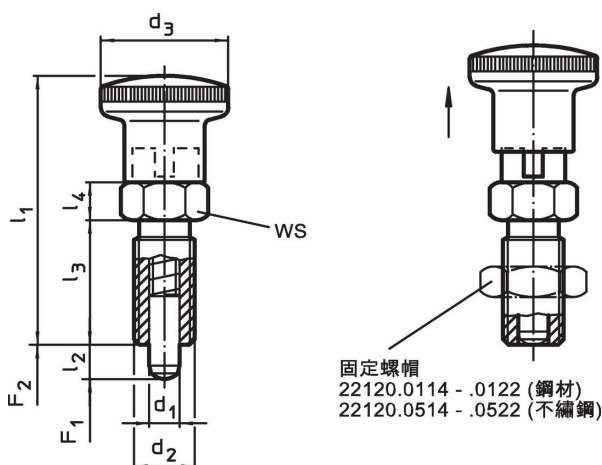

訂單資訊

尺寸			WS	彈簧荷重 ¹⁾		溫度		品號					
d ₁	d ₂	l ₂ min		F ₁ ~	F ₂ ~	min	max.						
-0,02				[N]		[°C]	[g]						
-0,05			[mm]										
帶旋鈕, 黑色, 鋼													
4	M 8 x 1	4	16	35,0	16	5	10	4,5	12,0	-30	80	12	22110.0123
4	M 8 x 1	6	16	35,0	16	5	10	4,0	12,5	-30	80	12	22110.0124
5	M10 x 1	5	19	40,0	18	6	12	5,0	15,0	-30	80	20	22110.0126
5	M10 x 1	8	19	40,0	18	6	12	5,0	18,0	-30	80	20	22110.0127
6	M12 x 1,5	6	23	48,0	22	6	14	6,5	19,0	-30	80	31	22110.0129
6	M12 x 1,5	9	23	48,0	22	6	14	6,0	25,0	-30	80	33	22110.0130
8	M16 x 1,5	8	28	58,0	26	8	17	8,5	26,0	-30	80	65	22110.0132
8	M16 x 1,5	12	28	58,0	26	8	17	8,5	28,0	-30	80	68	22110.0133
10	M16 x 1,5	12	28	58,0	26	8	17	9,5	38,0	-30	80	69	22110.0135
12	M20 x 1,5	15	33	67,0	33	10	22	11,5	40,0	-30	80	125	22110.0136
16	M24 x 2	20	33	78,5	38	12	27	13,0	54,0	-30	80	219	22110.0137

¹⁾ 統計平均值

d ₁ -0,02 -0,05	d ₂	l ₂ min	尺寸				WS [mm]	彈簧荷重 ¹⁾		min max. [°C]	[g]	品號	
			d ₃ [mm]	l ₁	l ₃	l ₄		F ₁ ~ [N]	F ₂ ~ [N]				
帶旋鈕，黑色，不銹鋼													
4	M 8 x 1	4	16	35,0	16	5	10	4,5	12,0	-30	80	12	22110.0223
4	M 8 x 1	6	16	35,0	16	5	10	4,0	12,5	-30	80	12	22110.0224
5	M10 x 1	5	19	40,0	18	6	12	5,0	15,0	-30	80	20	22110.0226
5	M10 x 1	8	19	40,0	18	6	12	5,0	18,0	-30	80	20	22110.0227
6	M12 x 1,5	6	23	48,0	22	6	14	6,5	19,0	-30	80	31	22110.0229
6	M12 x 1,5	9	23	48,0	22	6	14	6,0	25,0	-30	80	33	22110.0230
8	M16 x 1,5	8	28	58,0	26	8	17	8,5	26,0	-30	80	65	22110.0232
8	M16 x 1,5	12	28	58,0	26	8	17	8,5	28,0	-30	80	68	22110.0233
10	M16 x 1,5	12	28	58,0	26	8	17	9,5	38,0	-30	80	69	22110.0235
12	M20 x 1,5	15	33	67,0	33	10	22	11,5	40,0	-30	80	125	22110.0236
16	M24 x 2	20	33	78,5	38	12	27	13,0	54,0	-30	80	219	22110.0237
帶旋鈕，紅色，鋼													
4	M 8 x 1	4	16	35,0	16	5	10	4,5	12,0	-30	80	11	22110.2123
4	M 8 x 1	6	16	35,0	16	5	10	4,0	12,5	-30	80	13	22110.2124
5	M10 x 1	5	19	40,0	18	6	12	5,0	15,0	-30	80	21	22110.2126
5	M10 x 1	8	19	40,0	18	6	12	5,0	18,0	-30	80	21	22110.2127
6	M12 x 1,5	6	23	48,0	22	6	14	6,5	19,0	-30	80	33	22110.2129
6	M12 x 1,5	9	23	48,0	22	6	14	6,0	25,0	-30	80	32	22110.2130
8	M16 x 1,5	8	28	58,0	26	8	17	8,5	26,0	-30	80	65	22110.2132
8	M16 x 1,5	12	28	58,0	26	8	17	8,5	28,0	-30	80	69	22110.2133
10	M16 x 1,5	12	28	58,0	26	8	17	9,5	38,0	-30	80	70	22110.2135
12	M20 x 1,5	15	33	71,5	33	10	22	11,5	40,0	-30	80	127	22110.2136
16	M24 x 2	20	33	78,5	38	12	27	13,0	54,0	-30	80	200	22110.2137
帶旋鈕，紅色，不銹鋼													
4	M 8 x 1	4	16	35,0	16	5	10	4,5	12,0	-30	80	11	22110.2223
4	M 8 x 1	6	16	35,0	16	5	10	4,0	12,5	-30	80	13	22110.2224
5	M10 x 1	5	19	40,0	18	6	12	5,0	15,0	-30	80	21	22110.2226
5	M10 x 1	8	19	40,0	18	6	12	5,0	18,0	-30	80	21	22110.2227
6	M12 x 1,5	6	23	48,0	22	6	14	6,5	19,0	-30	80	33	22110.2229
6	M12 x 1,5	9	23	48,0	22	6	14	6,0	25,0	-30	80	32	22110.2230
8	M16 x 1,5	8	28	58,0	26	8	17	8,5	26,0	-30	80	65	22110.2232
8	M16 x 1,5	12	28	58,0	26	8	17	8,5	28,0	-30	80	69	22110.2233
10	M16 x 1,5	12	28	58,0	26	8	17	9,5	38,0	-30	80	70	22110.2235
12	M20 x 1,5	15	33	71,5	33	10	22	11,5	40,0	-30	80	127	22110.2236
16	M24 x 2	20	33	78,5	38	12	27	13,0	54,0	-30	80	200	22110.2237

¹⁾ 統計平均值

配件

	尺寸	扳手尺寸	[g]	品號
	d ₂ [mm]	[mm]		
鎖緊螺母 ISO 8675 (DIN 439), 鋼				
	M 8 x 1	13	2,7	22120.0114
	M10 x 1	16	5,2	22120.0115
	M12 x 1,5	18	7,5	22120.0116
	M16 x 1,5	24	15,0	22120.0118
	M20 x 1,5	30	32,0	22120.0120
	M24 x 2	36	58,0	22120.0122
鎖緊螺母 ISO 8675 (DIN 439), 不銹鋼				
	M 8 x 1	13	2,7	22120.0514
	M10 x 1	16	5,2	22120.0515
	M12 x 1,5	18	7,5	22120.0516
	M16 x 1,5	24	15,0	22120.0518
	M20 x 1,5	30	32,0	22120.0520
	M24 x 2	36	58,0	22120.0522

應用範例

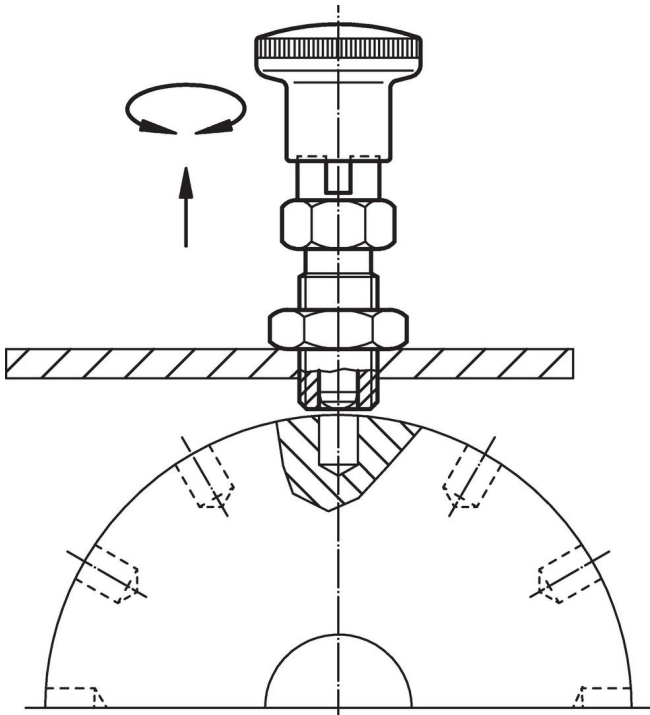

遵守

有關詳細的合規信息，請選擇所需的貨號。