

分割定位柱的迷你分割

EH 22110.



產品描述

特別適合鎖附薄板。
效能於最小空間需求。

材質

本體
• 鋼，鍍鋅
• 不鏽鋼 1.4305

固定梢子
• 不鏽鋼 1.4305

手把
• 塑膠(PA6)，黑色，無光澤的
• 熱塑性塑膠 PA 6，紅色，暗淡

組裝

鎖入迷你分割定位柱。提起旋鈕，六角將會鬆開以便組立。

螺絲長度可由分割定位柱襯套調整 (EH 22120.)。

操作

當使用自鎖型旋鈕，拉出旋鈕，轉30度並由一個缺口夾住。

更多資訊

注意事項

不可移動的旋鈕。

更多產品

- 距離調整環，適用於分割定位柱

圖面

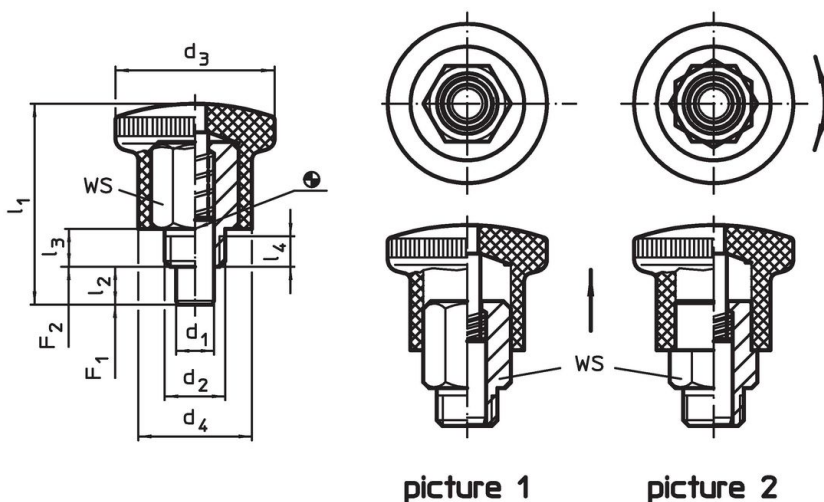

picture 1

picture 2

訂單資訊

尺寸								WS	彈簧荷重 ¹⁾		溫度		重量	品號
d ₁	d ₂	d ₃	d ₄	l ₁	l ₂ min	l ₃	l ₄ min		F ₁ ~	F ₂ ~	min	max.		
0 -0,06								[N]		[°C]				
無鎖定，旋鈕黑色 – 相片 1, 鋼														
4	M 8 x 0,75	21	15	26,5	5	5	3,5	10	4,5	12	-30	80	14	22110.0024
5	M 8 x 0,75	21	15	26,5	5	5	3,5	10	4,5	12	-30	80	14	22110.0026
6	M10 x 1	25	18	34,0	7	7	4,5	12	5,0	18	-30	80	25	22110.0028
7	M10 x 1	25	18	34,0	7	7	4,5	12	5,0	18	-30	80	26	22110.0030
without locking, knob red – 相片 1, 鋼														
4	M 8 x 0,75	21	15	26,5	5	5	3,5	10	4,5	12	-30	80	14	22110.2024
5	M 8 x 0,75	21	15	26,5	5	5	3,5	10	4,5	12	-30	80	14	22110.2026
6	M10 x 1	25	18	34,0	7	7	4,5	12	5,0	18	-30	80	25	22110.2028
7	M10 x 1	25	18	34,0	7	7	4,5	12	5,0	18	-30	80	25	22110.2030

¹⁾ 統計平均值

d ₁ 0 -0,06	d ₂	d ₃	尺寸					WS [mm]	彈簧荷重 ¹⁾		溫度		重量 [g]	品號
			d ₄	l ₁	l ₂ min	l ₃	l ₄ min		F ₁ ~ [N]	F ₂ ~ [N]	min [°C]	max.		
帶鎖定，旋鈕黑色 – 相片 2, 鋼														
4	M 8 x 0,75	21	15	26,5	5	5	3,5	10	4,5	12	-30	80	13	22110.0034
5	M 8 x 0,75	21	15	26,5	5	5	3,5	10	4,5	12	-30	80	14	22110.0036
6	M10 x 1	25	18	34,0	7	7	4,5	12	5,0	18	-30	80	24	22110.0038
7	M10 x 1	25	18	34,0	7	7	4,5	12	5,0	18	-30	80	25	22110.0040
帶鎖定，旋鈕紅色 – 相片 2, 鋼														
4	M 8 x 0,75	21	15	26,5	5	5	3,5	10	4,5	12	-30	80	13	22110.2034
5	M 8 x 0,75	21	15	26,5	5	5	3,5	10	4,5	12	-30	80	14	22110.2036
6	M10 x 1	25	18	34,0	7	7	4,5	12	5,0	18	-30	80	24	22110.2038
7	M10 x 1	25	18	34,0	7	7	4,5	12	5,0	18	-30	80	25	22110.2040
無鎖定，旋鈕黑色 – 相片 1, 不銹鋼														
4	M 8 x 0,75	21	15	26,5	5	5	3,5	10	4,5	12	-30	80	14	22110.0044
5	M 8 x 0,75	21	15	26,5	5	5	3,5	10	4,5	12	-30	80	14	22110.0046
6	M10 x 1	25	18	34,0	7	7	4,5	12	5,0	18	-30	80	25	22110.0048
7	M10 x 1	25	18	34,0	7	7	4,5	12	5,0	18	-30	80	26	22110.0050
without locking, knob red – 相片 1, 不銹鋼														
4	M 8 x 0,75	21	15	26,5	5	5	3,5	10	4,5	12	-30	80	14	22110.2044
5	M 8 x 0,75	21	15	26,5	5	5	3,5	10	4,5	12	-30	80	14	22110.2046
6	M10 x 1	25	18	34,0	7	7	4,5	12	5,0	18	-30	80	25	22110.2048
7	M10 x 1	25	18	34,0	7	7	4,5	12	5,0	18	-30	80	25	22110.2050
帶鎖定，旋鈕黑色 – 相片 2, 不銹鋼														
4	M 8 x 0,75	21	15	26,5	5	5	3,5	10	4,5	12	-30	80	13	22110.0054
5	M 8 x 0,75	21	15	26,5	5	5	3,5	10	4,5	12	-30	80	14	22110.0056
6	M10 x 1	25	18	34,0	7	7	4,5	12	5,0	18	-30	80	24	22110.0058
7	M10 x 1	25	18	34,0	7	7	4,5	12	5,0	18	-30	80	25	22110.0060
帶鎖定，旋鈕紅色 – 相片 2, 不銹鋼														
4	M 8 x 0,75	21	15	26,5	5	5	3,5	10	4,5	12	-30	80	13	22110.2054
5	M 8 x 0,75	21	15	26,5	5	5	3,5	10	4,5	12	-30	80	14	22110.2056
6	M10 x 1	25	18	34,0	7	7	4,5	12	5,0	18	-30	80	24	22110.2058
7	M10 x 1	25	18	34,0	7	7	4,5	12	5,0	18	-30	80	25	22110.2060

¹⁾ 統計平均值

應用範例



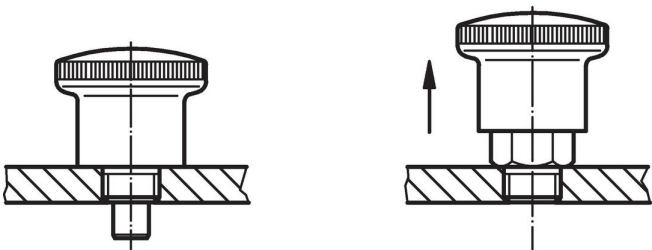
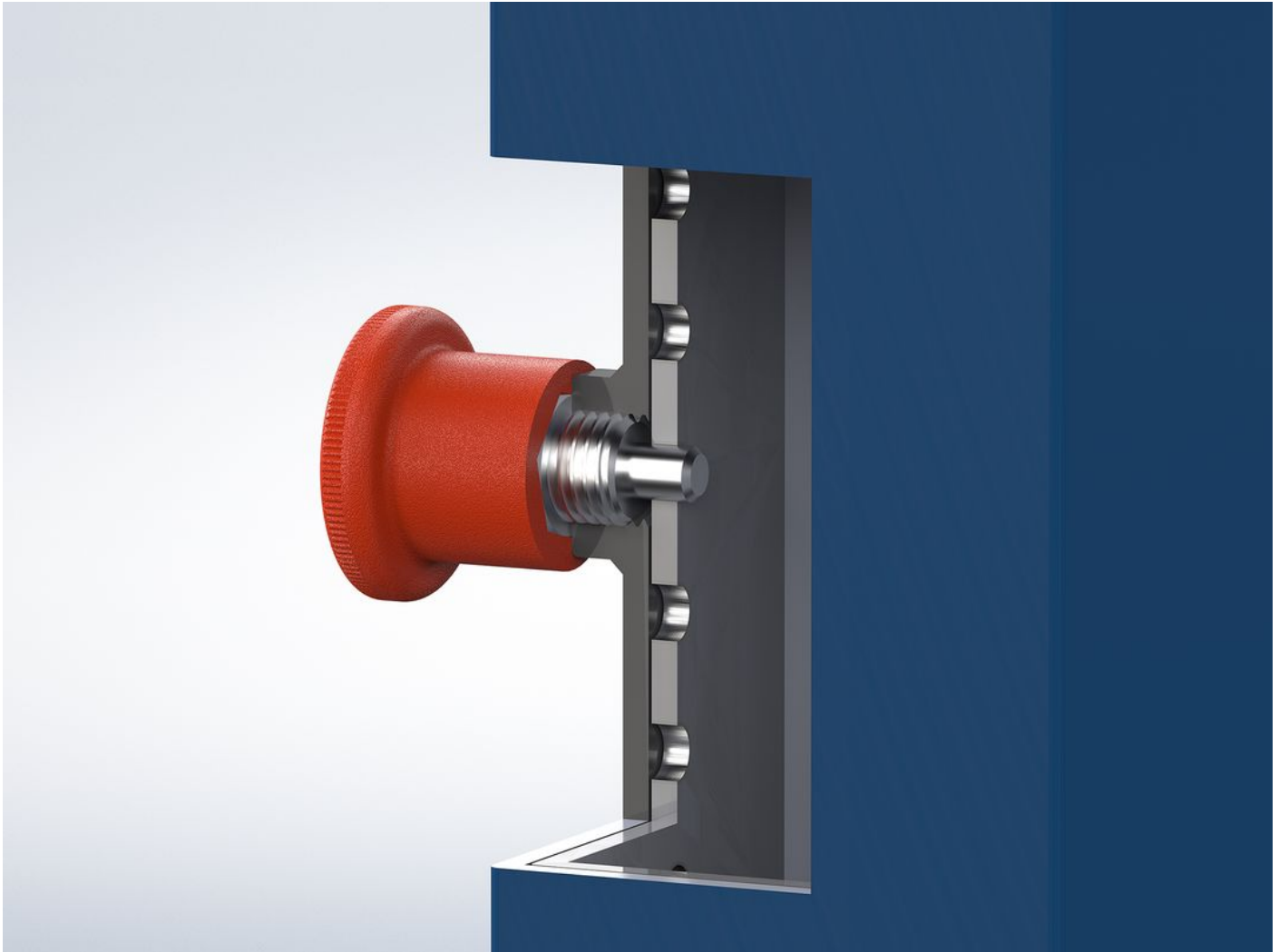

遵守

有關詳細的合規信息，請選擇所需的貨號。