

## 定位柱 · 有內六角形 EH 22060.



### 產品描述

適用於定位、供壓或頂舉。

### 材質

螺絲形支撐座  
 • 切削鋼，硬化，染黑  
 • 得林白塑膠 (POM)  
 • 不鏽鋼 1.4305, 氮化

### 本體

• 切削鋼，染黑  
 • 不鏽鋼 1.4305

### 彈簧

• 不銹鋼

### 組裝

定位柱可藉由溝槽或內六角來固定及移除。  
 利用專用工具在溝槽上固定 (頂銷端)

### 特性

標準彈簧荷重: 無標示  
 重彈簧荷重: 以兩條線標示

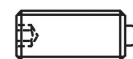

Standard spring load

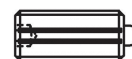

Heavy spring load

### 更多資訊

### 注意事項

特殊的樣式歡迎洽詢。  
 定位柱經過特別測試，以得知其彈簧的範圍和作用。

### 參考

螺紋鎖附依需求，請參閱附錄 - 技術數據 -

### 更多產品

- 定位柱, 有內六角和密封墊
- 托座, 用於定位柱

### 圖面

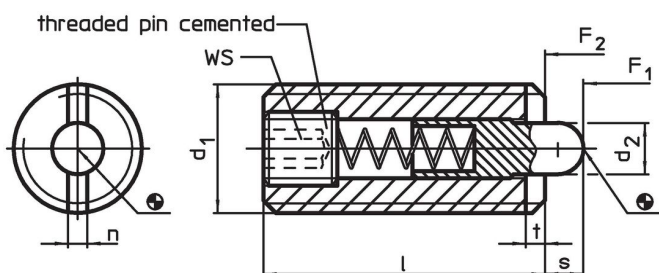

### 訂單資訊

| d <sub>1</sub> | d <sub>2</sub> | 尺寸 |     |     | WS  | 行程<br>s | 彈簧荷重 <sup>1)</sup>  |                     | 溫度  |      | 重量<br>[g] | 品號         |
|----------------|----------------|----|-----|-----|-----|---------|---------------------|---------------------|-----|------|-----------|------------|
|                |                | l  | n   | t   |     |         | F <sub>1</sub><br>~ | F <sub>2</sub><br>~ | min | max. |           |            |
| [mm]           |                |    |     |     |     |         |                     |                     |     |      |           |            |
| 切削鋼, 標準彈簧荷重    |                |    |     |     |     |         |                     |                     |     |      |           |            |
| M 3            | 1,0            | 12 | 0,4 | 0,5 | 0,7 | 1,0     | 2,5                 | 3                   | -   | 250  | 0,4       | 22060.0003 |
| M 4            | 1,5            | 15 | 0,6 | 0,6 | 1,3 | 1,5     | 4,0                 | 16                  | -   | 250  | 0,9       | 22060.0004 |
| M 5            | 2,4            | 18 | 1,2 | 0,8 | 1,5 | 2,3     | 6,0                 | 20                  | -   | 250  | 1,7       | 22060.0005 |
| M 6            | 2,7            | 20 | 1,3 | 0,9 | 2,0 | 2,5     | 7,0                 | 22                  | -   | 250  | 2,8       | 22060.0006 |
| M 8            | 3,5            | 22 | 1,5 | 1,4 | 2,5 | 3,0     | 8,0                 | 38                  | -   | 250  | 5,7       | 22060.0008 |
| M10            | 4,0            | 22 | 1,5 | 1,4 | 3,0 | 3,0     | 10,0                | 38                  | -   | 250  | 9,2       | 22060.0010 |
| M12            | 6,0            | 28 | 2,7 | 2,0 | 4,0 | 4,0     | 10,0                | 54                  | -   | 250  | 16,0      | 22060.0012 |
| M16            | 7,5            | 32 | 3,2 | 2,5 | 5,0 | 5,0     | 38,0                | 100                 | -   | 250  | 35,0      | 22060.0016 |
| M20            | 10,0           | 40 | 3,7 | 3,0 | 6,0 | 7,0     | 58,0                | 140                 | -   | 250  | 67,0      | 22060.0020 |
| M24            | 12,0           | 52 | 3,7 | 3,0 | 8,0 | 10,0    | 80,0                | 180                 | -   | 250  | 129,0     | 22060.0024 |

<sup>1)</sup> 統計平均值

| d <sub>1</sub>           | d <sub>2</sub> | 尺寸        |     |     | WS<br>[mm] | 行程<br>s<br>[mm] | 彈簧荷重 <sup>1)</sup>         |                            | min<br>max.<br>[°C] | g   | 品號    |            |
|--------------------------|----------------|-----------|-----|-----|------------|-----------------|----------------------------|----------------------------|---------------------|-----|-------|------------|
|                          |                | l<br>[mm] | n   | t   |            |                 | F <sub>1</sub><br>~<br>[N] | F <sub>2</sub><br>~<br>[N] |                     |     |       |            |
| <b>切削鋼，增強彈簧荷重</b>        |                |           |     |     |            |                 |                            |                            |                     |     |       |            |
| M 5                      | 2,4            | 18        | 1,2 | 0,8 | 1,5        | 2,3             | 15,0                       | 44                         | -                   | 250 | 1,6   | 22060.0105 |
| M 6                      | 2,7            | 20        | 1,3 | 0,9 | 2,0        | 2,5             | 20,0                       | 48                         | -                   | 250 | 2,8   | 22060.0106 |
| M 8                      | 3,5            | 22        | 1,5 | 1,4 | 2,5        | 3,0             | 26,0                       | 70                         | -                   | 250 | 5,7   | 22060.0108 |
| M10                      | 4,0            | 22        | 1,5 | 1,4 | 3,0        | 3,0             | 26,0                       | 70                         | -                   | 250 | 9,1   | 22060.0110 |
| M12                      | 6,0            | 28        | 2,7 | 2,0 | 4,0        | 4,0             | 51,0                       | 122                        | -                   | 250 | 16,0  | 22060.0112 |
| M16                      | 7,5            | 32        | 3,2 | 2,5 | 5,0        | 5,0             | 72,0                       | 164                        | -                   | 250 | 26,0  | 22060.0116 |
| M20                      | 10,0           | 40        | 3,7 | 3,0 | 6,0        | 7,0             | 88,0                       | 206                        | -                   | 250 | 67,0  | 22060.0120 |
| M24                      | 12,0           | 52        | 3,7 | 3,0 | 8,0        | 10,0            | 94,0                       | 250                        | -                   | 250 | 129,0 | 22060.0124 |
| <b>切削鋼，梢子得林塑膠，標準彈簧荷重</b> |                |           |     |     |            |                 |                            |                            |                     |     |       |            |
| M 4                      | 1,5            | 15        | 0,6 | 0,6 | 1,3        | 1,5             | 4,0                        | 16                         | -30                 | 50  | 0,9   | 22060.0204 |
| M 5                      | 2,4            | 18        | 1,2 | 0,8 | 1,5        | 2,3             | 6,0                        | 20                         | -30                 | 50  | 1,5   | 22060.0205 |
| M 6                      | 2,7            | 20        | 1,3 | 0,9 | 2,0        | 2,5             | 7,0                        | 22                         | -30                 | 50  | 2,3   | 22060.0206 |
| M 8                      | 3,5            | 22        | 1,5 | 1,4 | 2,5        | 3,0             | 8,0                        | 38                         | -30                 | 50  | 5,0   | 22060.0208 |
| M10                      | 4,0            | 22        | 1,5 | 1,4 | 3,0        | 3,0             | 10,0                       | 38                         | -30                 | 50  | 8,1   | 22060.0210 |
| M12                      | 6,0            | 28        | 2,7 | 2,0 | 4,0        | 4,0             | 10,0                       | 54                         | -30                 | 50  | 14,0  | 22060.0212 |
| M16                      | 7,5            | 32        | 3,2 | 2,5 | 5,0        | 5,0             | 38,0                       | 100                        | -30                 | 50  | 31,0  | 22060.0216 |
| M20                      | 10,0           | 40        | 3,7 | 3,0 | 6,0        | 7,0             | 58,0                       | 140                        | -30                 | 50  | 77,0  | 22060.0220 |
| M24                      | 12,0           | 52        | 3,7 | 3,0 | 8,0        | 10,0            | 80,0                       | 180                        | -30                 | 50  | 143,0 | 22060.0224 |
| <b>不銹鋼，標準彈簧荷重</b>        |                |           |     |     |            |                 |                            |                            |                     |     |       |            |
| M 3                      | 1,0            | 12        | 0,4 | 0,5 | 0,7        | 1,0             | 2,5                        | 3                          | -                   | 250 | 0,9   | 22060.0403 |
| M 4                      | 1,5            | 15        | 0,6 | 0,6 | 1,3        | 1,5             | 4,0                        | 16                         | -                   | 250 | 0,9   | 22060.0404 |
| M 5                      | 2,4            | 18        | 1,2 | 0,8 | 1,5        | 2,3             | 6,0                        | 20                         | -                   | 250 | 1,7   | 22060.0405 |
| M 6                      | 2,7            | 20        | 1,3 | 0,9 | 2,0        | 2,5             | 6,0                        | 22                         | -                   | 250 | 2,8   | 22060.0406 |
| M 8                      | 3,5            | 22        | 1,5 | 1,4 | 2,5        | 3,0             | 8,0                        | 38                         | -                   | 250 | 4,6   | 22060.0408 |
| M10                      | 4,0            | 22        | 1,5 | 1,4 | 3,0        | 3,0             | 10,0                       | 38                         | -                   | 250 | 9,5   | 22060.0410 |
| M12                      | 6,0            | 28        | 2,7 | 2,0 | 4,0        | 4,0             | 10,0                       | 54                         | -                   | 250 | 16,0  | 22060.0412 |
| M16                      | 7,5            | 32        | 3,2 | 2,5 | 5,0        | 5,0             | 38,0                       | 100                        | -                   | 250 | 34,0  | 22060.0416 |
| M20                      | 10,0           | 40        | 3,7 | 3,0 | 6,0        | 7,0             | 58,0                       | 140                        | -                   | 250 | 67,0  | 22060.0420 |
| M24                      | 12,0           | 52        | 3,7 | 3,0 | 8,0        | 10,0            | 80,0                       | 180                        | -                   | 250 | 164,0 | 22060.0424 |
| <b>不銹鋼，增加彈簧荷重</b>        |                |           |     |     |            |                 |                            |                            |                     |     |       |            |
| M 5                      | 2,4            | 18        | 1,2 | 0,8 | 1,5        | 2,3             | 15,0                       | 44                         | -                   | 250 | 2,2   | 22060.0505 |
| M 6                      | 2,7            | 20        | 1,3 | 0,9 | 2,0        | 2,5             | 20,0                       | 48                         | -                   | 250 | 4,1   | 22060.0506 |
| M 8                      | 3,5            | 22        | 1,5 | 1,4 | 2,5        | 3,0             | 26,0                       | 70                         | -                   | 250 | 7,4   | 22060.0508 |
| M10                      | 4,0            | 22        | 1,5 | 1,4 | 3,0        | 3,0             | 26,0                       | 70                         | -                   | 250 | 12,0  | 22060.0510 |
| M12                      | 6,0            | 28        | 2,7 | 2,0 | 4,0        | 4,0             | 51,0                       | 122                        | -                   | 250 | 22,0  | 22060.0512 |
| M16                      | 7,5            | 32        | 3,2 | 2,5 | 5,0        | 5,0             | 72,0                       | 164                        | -                   | 250 | 46,0  | 22060.0516 |
| M20                      | 10,0           | 40        | 3,7 | 3,0 | 6,0        | 7,0             | 88,0                       | 206                        | -                   | 250 | 87,0  | 22060.0520 |
| M24                      | 12,0           | 52        | 3,7 | 3,0 | 8,0        | 10,0            | 94,0                       | 250                        | -                   | 250 | 167,0 | 22060.0524 |
| <b>不銹鋼，梢子得林塑膠，標準彈簧荷重</b> |                |           |     |     |            |                 |                            |                            |                     |     |       |            |
| M 4                      | 1,5            | 15        | 0,6 | 0,6 | 1,3        | 1,5             | 4,0                        | 16                         | -30                 | 50  | 0,9   | 22060.0604 |
| M 5                      | 2,4            | 18        | 1,2 | 0,8 | 1,5        | 2,3             | 6,0                        | 20                         | -30                 | 50  | 1,6   | 22060.0605 |
| M 6                      | 2,7            | 20        | 1,3 | 0,9 | 2,0        | 2,5             | 7,0                        | 22                         | -30                 | 50  | 2,5   | 22060.0606 |
| M 8                      | 3,5            | 22        | 1,5 | 1,4 | 2,5        | 3,0             | 8,0                        | 38                         | -30                 | 50  | 5,1   | 22060.0608 |
| M10                      | 4,0            | 22        | 1,5 | 1,4 | 3,0        | 3,0             | 10,0                       | 38                         | -30                 | 50  | 8,5   | 22060.0610 |
| M12                      | 6,0            | 28        | 2,7 | 2,0 | 4,0        | 4,0             | 10,0                       | 54                         | -30                 | 50  | 14,0  | 22060.0612 |
| M16                      | 7,5            | 32        | 3,2 | 2,5 | 5,0        | 5,0             | 38,0                       | 100                        | -30                 | 50  | 31,0  | 22060.0616 |
| M20                      | 10,0           | 40        | 3,7 | 3,0 | 6,0        | 7,0             | 58,0                       | 140                        | -30                 | 50  | 77,0  | 22060.0620 |
| M24                      | 12,0           | 52        | 3,7 | 3,0 | 8,0        | 10,0            | 80,0                       | 180                        | -30                 | 50  | 143,0 | 22060.0624 |
| <b>不銹鋼，熱塑性塑膠銷，重彈簧負載</b>  |                |           |     |     |            |                 |                            |                            |                     |     |       |            |
| M 5                      | 2,4            | 18        | 1,2 | 0,8 | 1,5        | 2,3             | 15,0                       | 44                         | -30                 | 50  | 1,9   | 22060.0705 |
| M 6                      | 2,7            | 20        | 1,3 | 0,9 | 2,0        | 2,5             | 20,0                       | 48                         | -30                 | 50  | 3,6   | 22060.0706 |
| M 8                      | 3,5            | 22        | 1,5 | 1,4 | 2,5        | 3,0             | 26,0                       | 70                         | -30                 | 50  | 6,6   | 22060.0708 |
| M10                      | 4,0            | 22        | 1,5 | 1,4 | 3,0        | 3,0             | 26,0                       | 70                         | -30                 | 50  | 11,0  | 22060.0710 |
| M12                      | 6,0            | 28        | 2,7 | 2,0 | 4,0        | 4,0             | 51,0                       | 122                        | -30                 | 50  | 20,0  | 22060.0712 |
| M16                      | 7,5            | 32        | 3,2 | 2,5 | 5,0        | 5,0             | 72,0                       | 164                        | -30                 | 50  | 43,0  | 22060.0716 |
| M20                      | 10,0           | 40        | 3,7 | 3,0 | 6,0        | 7,0             | 88,0                       | 206                        | -30                 | 50  | 75,0  | 22060.0720 |
| M24                      | 12,0           | 52        | 3,7 | 3,0 | 8,0        | 10,0            | 94,0                       | 250                        | -30                 | 50  | 146,0 | 22060.0724 |

<sup>1)</sup> 統計平均值

配件

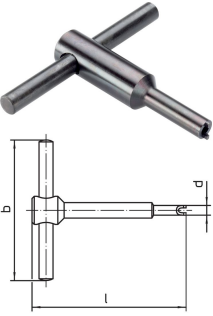
|   | d <sub>1</sub> | b   | 尺寸    |     | [g] | 品號                         |
|---|----------------|-----|-------|-----|-----|----------------------------|
|   |                |     | d     | l   |     |                            |
| 用於通過插槽安裝的組裝工具 (銷側)  |                |     |       |     |     |                            |
|  | M 3            | 50  | 2,35  | 55  | 17  | <a href="#">22060.0903</a> |
|   | M 4            | 50  | 3,00  | 55  | 18  | <a href="#">22060.0904</a> |
|   | M 5            | 50  | 4,00  | 60  | 21  | <a href="#">22060.0905</a> |
|   | M 6            | 60  | 4,70  | 60  | 30  | <a href="#">22060.0906</a> |
|   | M 8            | 60  | 6,45  | 70  | 39  | <a href="#">22060.0908</a> |
|   | M10            | 80  | 8,00  | 80  | 66  | <a href="#">22060.0910</a> |
|   | M12            | 80  | 9,80  | 80  | 72  | <a href="#">22060.0912</a> |
|   | M16            | 100 | 13,50 | 105 | 144 | <a href="#">22060.0916</a> |
|   | M20            | 100 | 17,00 | 115 | 162 | <a href="#">22060.0920</a> |
|   | M24            | 100 | 19,90 | 100 | 258 | <a href="#">22070.0838</a> |

應用範例

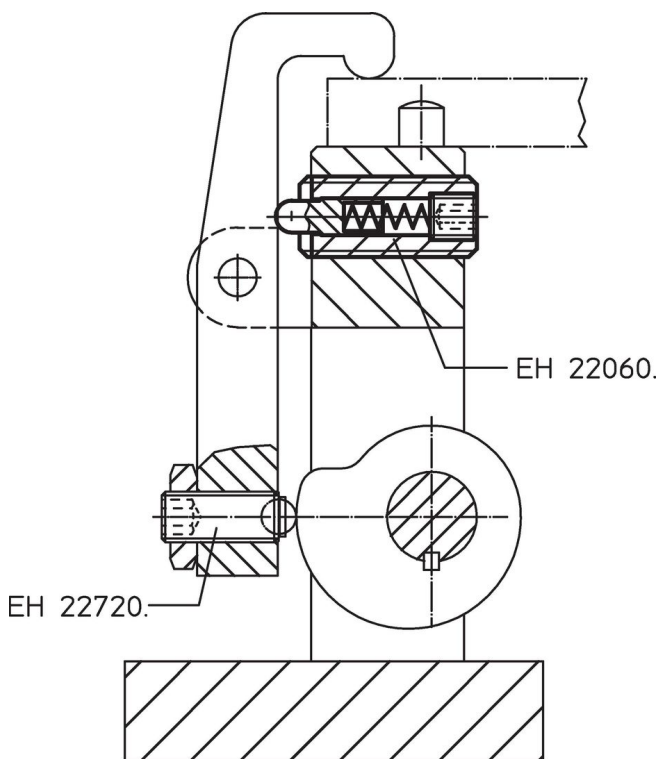

遵守

有關詳細的合規信息，請選擇所需的貨號。