

## 螺紋頂上銷 · 自鎖，帶把手

22354.5008



### 產品描述

此承載元件可普遍用於利用人力來運輸工件、工件夾持系統、揚聲器箱、容器等。  
Heavy-duty lifting element with handle for quick and easy use. For lifting loads, the threaded lifting pin is inserted into a threaded hole. In contrast to a ringbolt, time-consuming screwing in and out is therefore unnecessary.  
抗腐蝕和摩擦，因此適用於戶外。非常紮實，高負載力的沉澱硬化銷。

### 材質

梢子零件  
• 不鏽鋼 1.4542，沉澱硬化

把手  
• 鋁，藍電鍍

按鈕  
• 鋁，橘色，陽極

螺紋元件  
• 不鏽鋼 1.4542，沉澱硬化

彈簧  
• 不銹鋼

### 組裝

Threaded lifting pins can be mounted into a thread that is true to gauge.

Mounting:

1. Press in the button and hold it down.
2. Insert the threaded lifting pin.
3. Release the button (The button must be back in its original position. A clearly visible green marking on the press button indicates the correct position.)
4. Tighten the threaded lifting pin by hand, until it bears completely on the bearing surface.
5. It must be ensured that the threaded segments are engaged in the mounting thread.

Dismantling:

1. Unscrew the threaded lifting pin approx. a quarter of a turn anticlockwise.
2. Press in the button and hold it down.
3. Remove the threaded lifting pin.
4. Release the button.

### 操作

Each threaded lifting pin is supplied with operating instructions. This document is also available for download as a PDF.

### 圖面

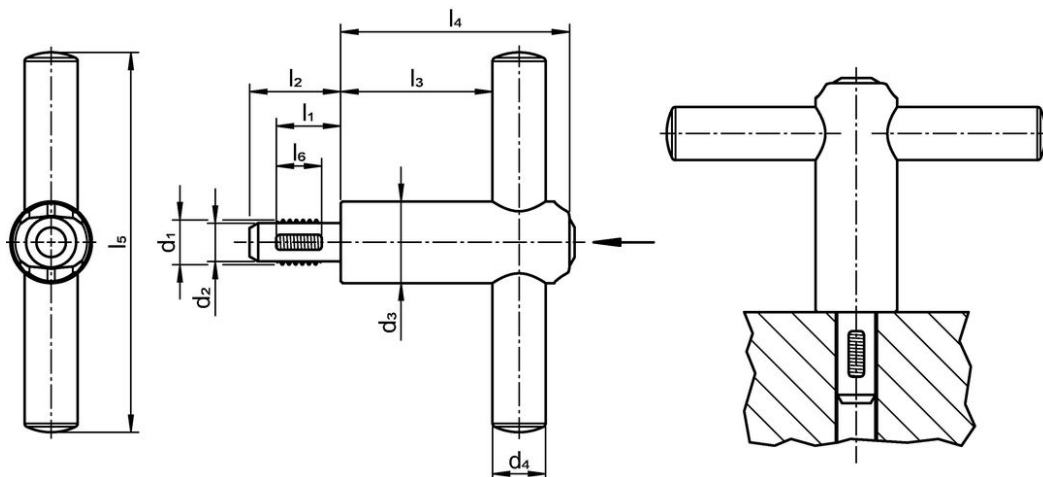

### 訂單資訊

尺寸										荷重能力	定位螺牙	溫度	重量	品號
d <sub>1</sub>	l <sub>1</sub>	d <sub>2</sub> -0,07	d <sub>3</sub>	d <sub>4</sub>	l <sub>2</sub>	l <sub>3</sub>	l <sub>4</sub>	l <sub>5</sub>	l <sub>6</sub>	F <sub>1</sub>		max.		
[mm]										[N]	[mm]	[°C]	[g]	
M8	12	6,62	21,5	14	17,3	40	60,3	100	8	500	M8	250	194	22354.5008

應用範例

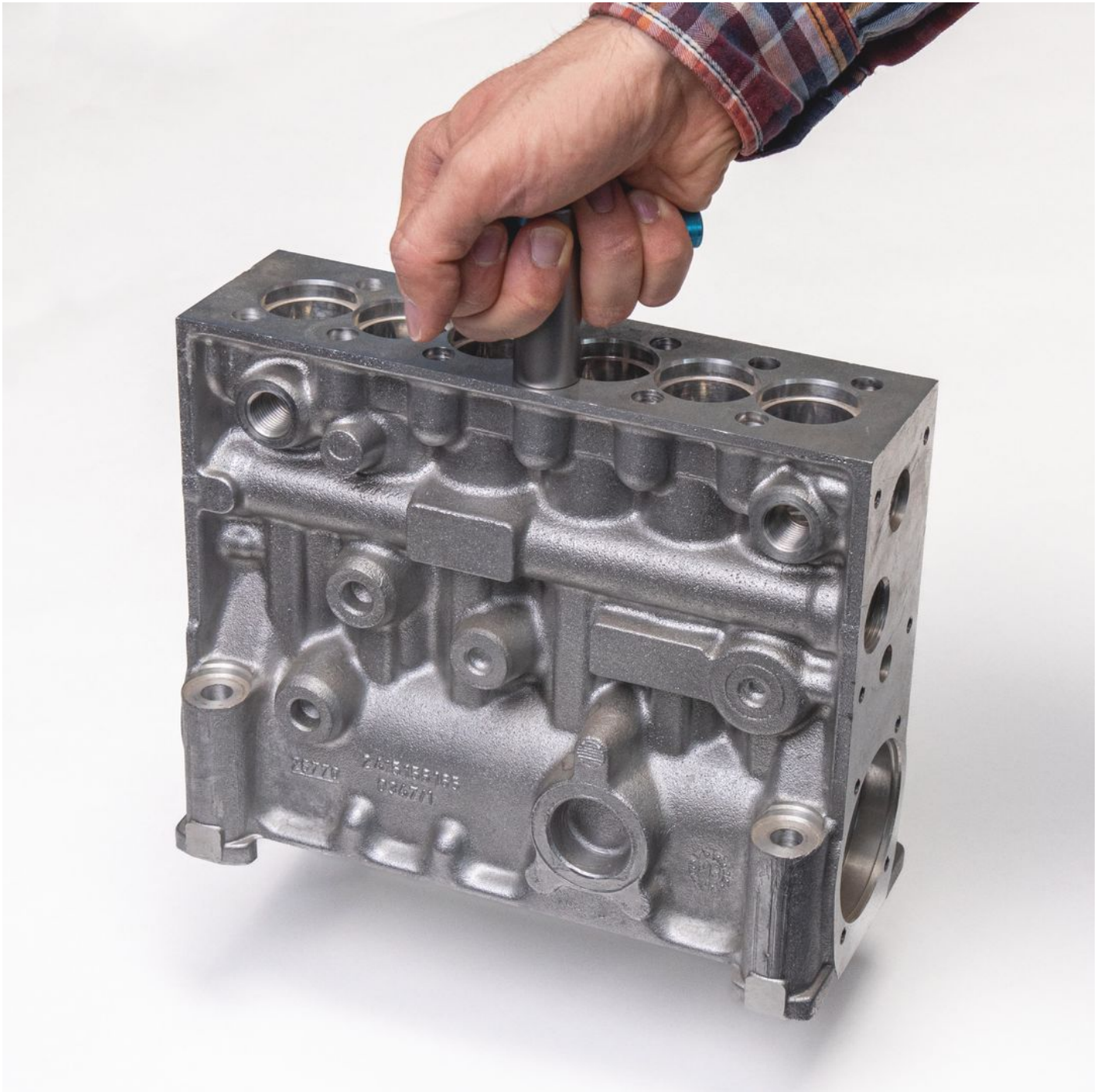



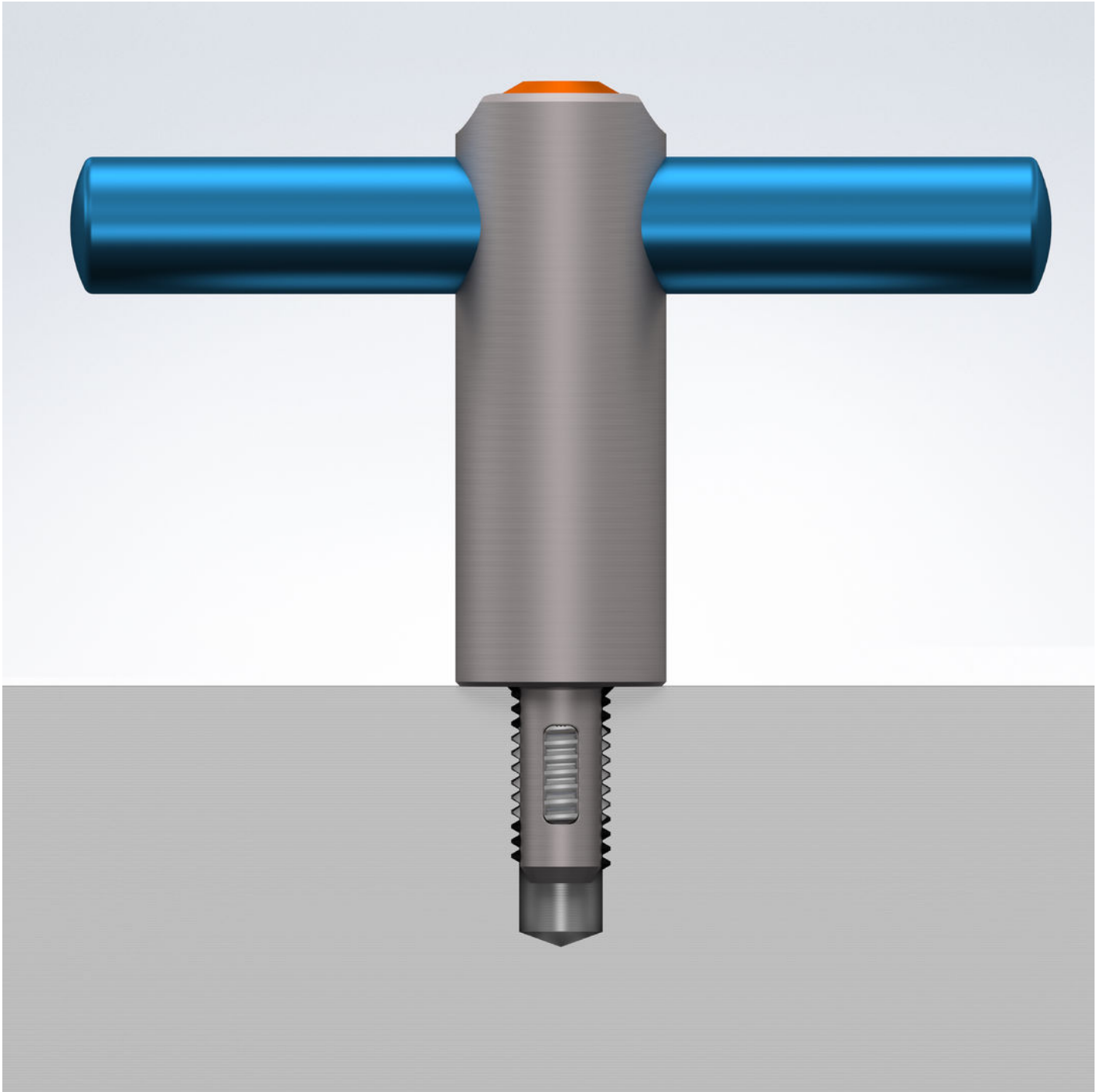

#### 遵守

##### 不符合 RoHS

不符合指令 2011/65/EU 和指令 2015/863

##### 含有 >0.1% w/w 的 SVHC 物質

含鉛 - SVHC [REACH] 清單截至 2024 年 6 月 27 日

##### 包含 65 號提案的物質



接觸鉛會導致癌症和生殖危害。接觸鎳會導致癌症。

<https://www.P65Warnings.ca.gov/>

##### 不含衝突礦物

本產品不含來自剛果民主共和國或鄰近國家的任何被指定為“衝突礦物”的物質，例如鈹、錫、金或鎢。