

Gängstift • med kultapp
EH 22570.

Produktbeskrivning

Gängstift med kultapp (EH 22570) kan kombineras med tryckplatta EH 22570.

Material

- Automatstål, 5.8 svartoxiderat
- Rostfritt stål 1.4305

Mer information

Ytterligare produkter

- Tryckplatta, plast

Ritning

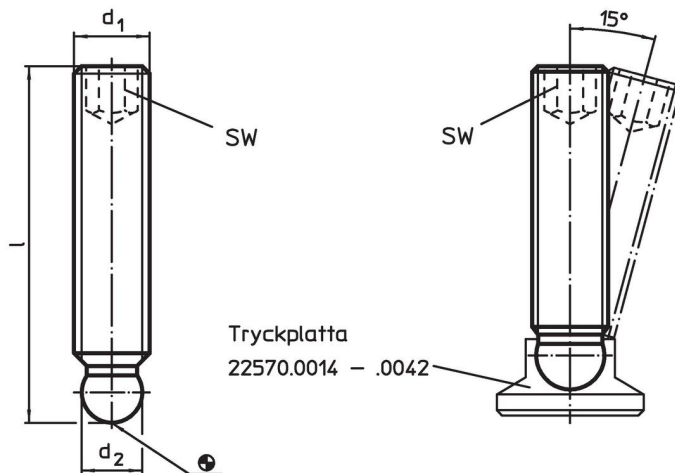

Orderinformation

d ₁	Dimension l [mm]	d ₂ +0,05	SW [mm]	 [g]	Art.nr.
Automatstål					
M 6	30	4,5	3	5,1	22570.0210
M 6	40	4,5	3	5,9	22570.0214
M 6	50	4,5	3	7,6	22570.0218
M 8	25	6,1	4	5,8	22570.0219
M 8	40	6,1	4	11,0	22570.0220
M 8	50	6,1	4	14,0	22570.0224
M 8	63	6,1	4	18,0	22570.0228
M10	40	7,8	5	16,0	22570.0248
M10	50	7,8	5	21,0	22570.0250
M10	63	7,8	5	27,0	22570.0254
M10	80	7,8	5	36,0	22570.0258
M12	40	9,4	6	23,0	22570.0316
M12	63	9,4	6	39,0	22570.0320
M12	80	9,4	6	51,0	22570.0324
M12	100	9,4	6	65,0	22570.0328
Rostfritt stål					
M 6	30	4,5	3	5,1	22570.0410
M 6	40	4,5	3	5,9	22570.0414
M 6	50	4,5	3	7,6	22570.0418
M 8	25	6,1	4	5,8	22570.0419
M 8	40	6,1	4	11,0	22570.0420
M 8	50	6,1	4	14,0	22570.0424
M 8	63	6,1	4	18,0	22570.0428
M10	40	7,8	5	16,0	22570.0448
M10	50	7,8	5	21,0	22570.0450
M10	63	7,8	5	27,0	22570.0454

d ₁	Dimension l [mm]	d ₂ +0,05	SW [mm]	 [g]	Art.nr.
M10	80	7,8	5	36,0	22570.0458
M12	40	9,4	6	23,0	22570.0516
M12	63	9,4	6	39,0	22570.0520
M12	80	9,4	6	51,0	22570.0524
M12	100	9,4	6	65,0	22570.0528

Användningsexempel

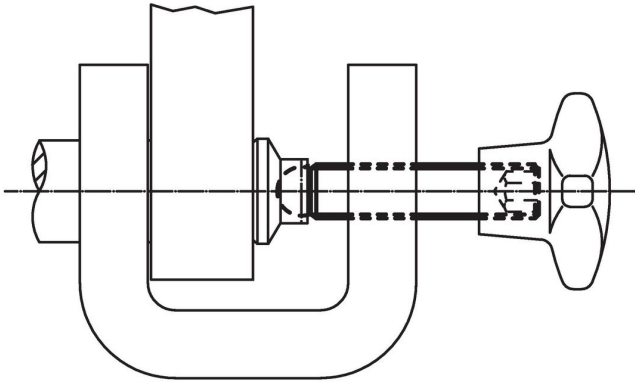

Överensstämmelse

För detaljerad överensstämmelseinformation, välj önskat artikelnummer.