

Indexbultar • med sexkantkrage och låsning, rostfritt stål A4 EH 22120.



Produktbeskrivning

Indexbultar används för indexering av hål.
Den rostfria A4-versionen säkerställer maximal korrosionsbeständighet.

Material

Kropp

- Rostfritt stål 1.4401

Låsplanne

- Rostfritt stål 1.4401 förnicklat

Grepp

- Thermoplast PA 6, gråsvart, matt
- Rostfritt stål 1.4401

Låsmutter

- Rostfritt stål 1.4401

Mer information

Not

Knopp ej demonterbar
Låsmutter beställs separat.

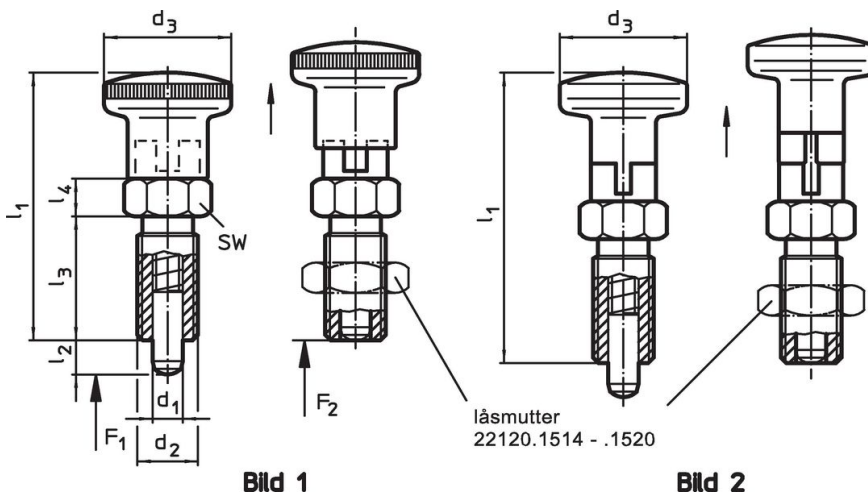

Ritning



Orderinformation



Dimension							Fj. tryck ¹⁾		min. max.		[g]	Art.nr.
d ₁	d ₂	l ₂ min.	d ₃	l ₁	l ₃	l ₄	F ₁ ~	F ₂ ~	min.	max.		
[mm]							[N]		[°C]			
med knopp av termoplast – Bild 1												
4	M 8 x 1	4	16	35,0	16	5	3,5	11	-30	80	12	22120.1144
4	M 8 x 1	6	16	35,0	16	6	4,5	16	-30	80	11	22120.1164
5	M10 x 1	5	19	35,0	16	5	3,0	11	-30	80	20	22120.1145
5	M10 x 1	8	19	48,0	22	6	4,0	20	-30	80	18	22120.1165
6	M12 x 1,5	6	23	40,0	18	6	3,0	12	-30	80	33	22120.1146
6	M12 x 1,5	9	23	58,0	26	8	6,0	23	-30	80	33	22120.1166
8	M16 x 1,5	8	28	58,0	26	8	7,0	26	-30	80	67	22120.1168
8	M16 x 1,5	12	28	40,0	18	6	3,0	14	-30	80	70	22120.1148
10	M16 x 1,5	12	28	58,0	26	8	7,5	32	-30	80	70	22120.1180
12	M20 x 1,5	15	33	71,5	33	10	9,0	32	-30	80	141	22120.1182
med knopp av rostfritt stål – Bild 2												
4	M 8 x 1	4	16	35,0	16	5	3,5	11	-	100	21	22120.1154
4	M 8 x 1	6	16	35,0	16	5	3,0	11	-	100	22	22120.1174
5	M10 x 1	5	18	40,0	18	6	3,0	12	-	100	36	22120.1155
5	M10 x 1	8	18	40,0	18	6	3,0	14	-	100	37	22120.1175

¹⁾ Statistiskt medelvärde

d ₁ -0,02 -0,05	d ₂	Dimension					Fj. tryck ¹⁾		 min. max.		 [g]	Art.nr.
		l ₂ min.	d ₃	l ₁	l ₃	l ₄	F ₁ ~ [N]	F ₂ ~ [N]	[°C]			
[mm]												
6	M12 x 1,5	6	22	48,0	22	6	4,5	16	-	100	60	22120.1156
6	M12 x 1,5	9	22	48,0	22	6	4,0	20	-	100	63	22120.1176
8	M16 x 1,5	8	27	58,0	26	8	6,0	23	-	100	117	22120.1178
8	M16 x 1,5	12	27	58,0	26	8	7,0	26	-	100	118	22120.1158
10	M16 x 1,5	12	27	58,0	26	8	7,5	32	-	100	135	22120.1190
12	M20 x 1,5	15	32	71,5	33	10	9,0	32	-	100	229	22120.1192

¹⁾ Statistiskt medelvärde

Tillbehör

	Dimension	Nyckel storlek	 [g]	Art.nr.
	d ₂ [mm]	[mm]	[g]	
Låsmutter ISO 8675 (DIN 439), Rostfritt stål 1.4401				
	M 8 x 1	13	2,8	22120.1514
	M12 x 1,5	18	7,6	22120.1516
	M10 x 1	16	5,4	22120.1515
	M16 x 1,5	24	18,0	22120.1518
	M20 x 1,5	30	33,0	22120.1520

Överensstämmelse

För detaljerad överensstämmelseinformation, välj önskat artikelnummer.