

Indexbultar kompakt • med sexkant och låsning

EH 22110.

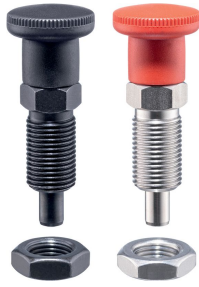

Produktbeskrivning

Indexbultar används för indexering av hål.
Modeller med / utan låsning har samma bygghöjd.
Tack vare gängsläppningen kan indexbulten skruvas helt in.

Material

Kropp

- Stål, svartoxiderat
- Rostfritt stål 1.4305

Låspinne

- Stål, härdat
- Rostfritt stål 1.4305, förnicklat

Grepp

- Termoplast (PA 6), svart, matt
- Termoplast PA 6, röd, matt

Montering

Gänglängden kan justeras genom distansringar för indexbultar (EH 22120.).

Drift

Knoppen dras ut och vrids 90° och säkras med ett hack (när låspinnen inte får skjuta ut).

Mer information

Not

Knopp ej demonterbar
Låsmutter beställs separat.

Ytterligare produkter

- Hållare, för indexbultar, gjuten zink,
- Lokaliseringsbussningar, för indexbultar
- Distansring, för indexbultar

Ritning

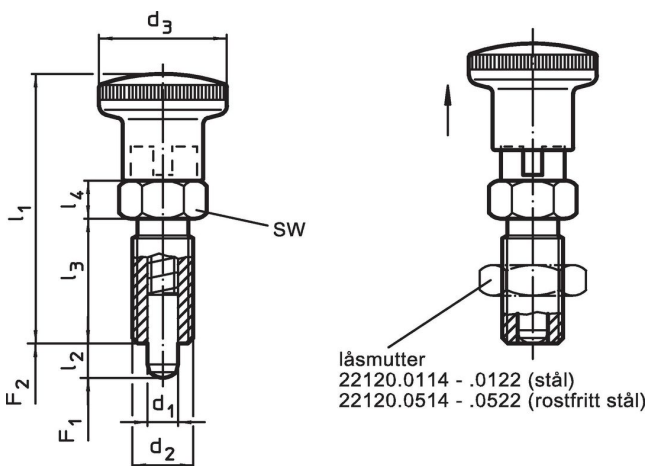

Orderinformation



d ₁	d ₂	Dimension					SW	Fj. tryck ¹⁾		min. max.		[g]	Art.nr.
		l ₂ min.	d ₃	l ₁	l ₃	l ₄		F ₁ ~	F ₂ ~	[°C]			
-0,02 -0,05			[mm]				[mm]	[N]		[°C]			
med knopp, svart, Stål													
4	M 8 x 1	4	16	35,0	16	5	10	4,5	12,0	-30	80	12	22110.0123
4	M 8 x 1	6	16	35,0	16	5	10	4,0	12,5	-30	80	12	22110.0124
5	M10 x 1	5	19	40,0	18	6	12	5,0	15,0	-30	80	20	22110.0126
5	M10 x 1	8	19	40,0	18	6	12	5,0	18,0	-30	80	20	22110.0127
6	M12 x 1,5	6	23	48,0	22	6	14	6,5	19,0	-30	80	31	22110.0129
6	M12 x 1,5	9	23	48,0	22	6	14	6,0	25,0	-30	80	33	22110.0130
8	M16 x 1,5	8	28	58,0	26	8	17	8,5	26,0	-30	80	65	22110.0132
8	M16 x 1,5	12	28	58,0	26	8	17	8,5	28,0	-30	80	68	22110.0133
10	M16 x 1,5	12	28	58,0	26	8	17	9,5	38,0	-30	80	69	22110.0135
12	M20 x 1,5	15	33	67,0	33	10	22	11,5	40,0	-30	80	125	22110.0136
16	M24 x 2	20	33	78,5	38	12	27	13,0	54,0	-30	80	219	22110.0137

¹⁾ Statistiskt medelvärde

d ₁ -0,02 -0,05	d ₂	Dimension					SW [mm]	Fj. tryck ¹⁾		min. max.		[g]	Art.nr.			
		l ₂ min.	d ₃	l ₁	l ₃	l ₄		F ₁ ~	F ₂ ~	[°C]						
[mm]													[N]	[N]	[°C]	[g]
med knapp, svart, Rostfritt stål																
4	M 8 x 1	4	16	35,0	16	5	10	4,5	12,0	-30	80	12	22110.0223			
4	M 8 x 1	6	16	35,0	16	5	10	4,0	12,5	-30	80	12	22110.0224			
5	M10 x 1	5	19	40,0	18	6	12	5,0	15,0	-30	80	20	22110.0226			
5	M10 x 1	8	19	40,0	18	6	12	5,0	18,0	-30	80	20	22110.0227			
6	M12 x 1,5	6	23	48,0	22	6	14	6,5	19,0	-30	80	31	22110.0229			
6	M12 x 1,5	9	23	48,0	22	6	14	6,0	25,0	-30	80	33	22110.0230			
8	M16 x 1,5	8	28	58,0	26	8	17	8,5	26,0	-30	80	65	22110.0232			
8	M16 x 1,5	12	28	58,0	26	8	17	8,5	28,0	-30	80	68	22110.0233			
10	M16 x 1,5	12	28	58,0	26	8	17	9,5	38,0	-30	80	69	22110.0235			
12	M20 x 1,5	15	33	67,0	33	10	22	11,5	40,0	-30	80	125	22110.0236			
16	M24 x 2	20	33	78,5	38	12	27	13,0	54,0	-30	80	219	22110.0237			
med knapp, röd, Stål																
4	M 8 x 1	4	16	35,0	16	5	10	4,5	12,0	-30	80	11	22110.2123			
4	M 8 x 1	6	16	35,0	16	5	10	4,0	12,5	-30	80	13	22110.2124			
5	M10 x 1	5	19	40,0	18	6	12	5,0	15,0	-30	80	21	22110.2126			
5	M10 x 1	8	19	40,0	18	6	12	5,0	18,0	-30	80	21	22110.2127			
6	M12 x 1,5	6	23	48,0	22	6	14	6,5	19,0	-30	80	33	22110.2129			
6	M12 x 1,5	9	23	48,0	22	6	14	6,0	25,0	-30	80	32	22110.2130			
8	M16 x 1,5	8	28	58,0	26	8	17	8,5	26,0	-30	80	65	22110.2132			
8	M16 x 1,5	12	28	58,0	26	8	17	8,5	28,0	-30	80	69	22110.2133			
10	M16 x 1,5	12	28	58,0	26	8	17	9,5	38,0	-30	80	70	22110.2135			
12	M20 x 1,5	15	33	71,5	33	10	22	11,5	40,0	-30	80	127	22110.2136			
16	M24 x 2	20	33	78,5	38	12	27	13,0	54,0	-30	80	200	22110.2137			
med knapp, röd, Rostfritt stål																
4	M 8 x 1	4	16	35,0	16	5	10	4,5	12,0	-30	80	11	22110.2223			
4	M 8 x 1	6	16	35,0	16	5	10	4,0	12,5	-30	80	13	22110.2224			
5	M10 x 1	5	19	40,0	18	6	12	5,0	15,0	-30	80	21	22110.2226			
5	M10 x 1	8	19	40,0	18	6	12	5,0	18,0	-30	80	21	22110.2227			
6	M12 x 1,5	6	23	48,0	22	6	14	6,5	19,0	-30	80	33	22110.2229			
6	M12 x 1,5	9	23	48,0	22	6	14	6,0	25,0	-30	80	32	22110.2230			
8	M16 x 1,5	8	28	58,0	26	8	17	8,5	26,0	-30	80	65	22110.2232			
8	M16 x 1,5	12	28	58,0	26	8	17	8,5	28,0	-30	80	69	22110.2233			
10	M16 x 1,5	12	28	58,0	26	8	17	9,5	38,0	-30	80	70	22110.2235			
12	M20 x 1,5	15	33	71,5	33	10	22	11,5	40,0	-30	80	127	22110.2236			
16	M24 x 2	20	33	78,5	38	12	27	13,0	54,0	-30	80	200	22110.2237			

¹⁾ Statistiskt medelvärde

Tillbehör

	Dimension	Nyckel storlek	[g]	Art.nr.
	d ₂ [mm]	[mm]		
Låsmutter ISO 8675 (DIN 439), Stål				
	M 8 x 1	13	2,7	22120.0114
	M10 x 1	16	5,2	22120.0115
	M12 x 1,5	18	7,5	22120.0116
	M16 x 1,5	24	15,0	22120.0118
	M20 x 1,5	30	32,0	22120.0120
	M24 x 2	36	58,0	22120.0122
Låsmutter ISO 8675 (DIN 439), Rostfritt stål				
	M 8 x 1	13	2,7	22120.0514
	M10 x 1	16	5,2	22120.0515
	M12 x 1,5	18	7,5	22120.0516
	M16 x 1,5	24	15,0	22120.0518
	M20 x 1,5	30	32,0	22120.0520
	M24 x 2	36	58,0	22120.0522

Användningsexempel

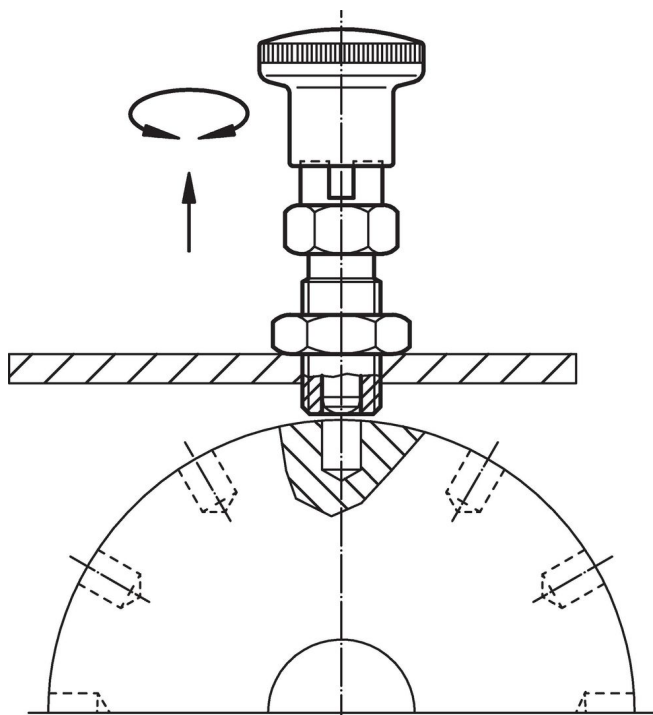

Överensstämmelse

För detaljerad överensstämmelseinformation, välj önskat artikelnummer.