

## Indexbultar • with mounting flange, horizontal, stainless steel

EH 22110.



### Produktbeskrivning

Indexbultar används för indexering av hål.

### Material

#### Huset

- Stainless steel 1.4308, precision casting, bright, matt blasted

#### Lås-pinne

- Rostfritt stål 1.4305

#### Grepp

- Termoplast (PA 6), svart, matt

#### Draging

- Rostfritt stål 1.4310

### Montering

Montering med hjälp av bricka ISO 7092.

### Drift

Vid användandet av läsbar modell, knappen dras ut, vrid den 90° och säkra med spåret (när lås-pinne inte får skjuta ut).

### Mer information

### Not

Knopp ej demonterbar

### Ritning

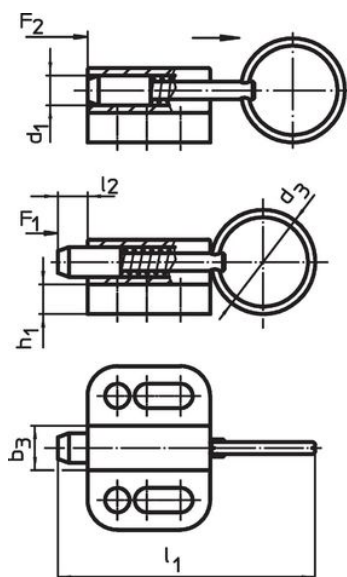

utan låsning

**Bild 1**

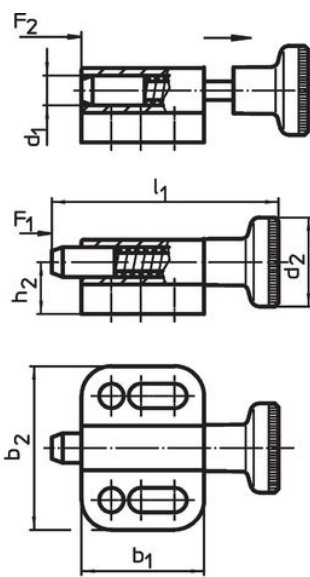

utan låsning

**Bild 2**

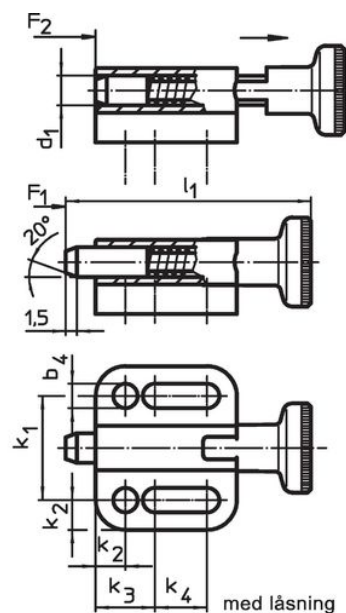

med låsning

**Bild 3**

### Orderinformation

Dimension															Fj. tryck <sup>1)</sup>		Temperatur		Vikt	Art.nr.				
d <sub>1</sub>	d <sub>2</sub>	d <sub>3</sub>	b <sub>1</sub>	b <sub>2</sub>	b <sub>3</sub>	b <sub>4</sub>	h <sub>1</sub>	h <sub>2</sub>	k <sub>1</sub>	k <sub>2</sub>	k <sub>3</sub>	k <sub>4</sub>	l <sub>1</sub>	l <sub>2</sub>	F <sub>1</sub>	F <sub>2</sub>	min.	max.			[g]			
h11						-0,2			±0,05					min.	~	~		[°C]						
[mm]																					[N]	[°C]	[g]	
<b>Med draging, ingen låsning – Bild 1</b>																								
4	-	14	16,5	22	6,0	3,3	4,0	7,0	14	4,0	8	4,5	34,5	4	3	12	-	100	12	22110.2304				
5	-	18	22,0	28	8,0	4,3	4,5	9,5	18	5,0	10	7,0	45,0	5	5	24	-	100	24	22110.2305				
6	-	24	27,5	32	10,0	5,4	5,0	10,5	21	5,5	12	10,0	57,5	6	5	21	-	100	42	22110.2306				
8	-	30	33,0	34	12,0	5,4	6,0	12,5	23	5,5	12	15,5	71,0	8	6	22	-	100	67	22110.2308				
10	-	30	35,0	39	14,5	6,5	6,0	14,5	27	6,0	15	13,5	75,0	10	4	25	-	100	93	22110.2310				
<b>Med knapp, ingen låsning – Bild 2</b>																								
4	12	-	16,5	22	6,0	3,3	4,0	7,0	14	4,0	8	4,5	30,5	4	3	12	-30	80	14	22110.2324				
5	16	-	22,0	28	8,0	4,3	4,5	9,5	18	5,0	10	7,0	40,0	5	5	24	-30	80	26	22110.2325				
6	18	-	27,5	32	10,0	5,4	5,0	10,5	21	5,5	12	10,0	49,0	6	5	21	-30	80	44	22110.2326				
8	21	-	33,0	34	12,0	5,4	6,0	12,5	23	5,5	12	15,5	59,0	8	6	22	-30	80	67	22110.2328				
10	25	-	35,0	39	14,5	6,5	6,0	14,5	27	6,0	15	13,5	67,5	10	4	25	-30	80	99	22110.2330				

<sup>1)</sup> Statistiskt medelvärde

Dimension															Fj. tryck <sup>1)</sup>		min.   max.		[g]	Art.nr.	
d <sub>1</sub> h11	d <sub>2</sub>	d <sub>3</sub>	b <sub>1</sub>	b <sub>2</sub>	b <sub>3</sub>	b <sub>4</sub> -0,2	h <sub>1</sub>	h <sub>2</sub>	k <sub>1</sub> ±0,05	k <sub>2</sub>	k <sub>3</sub>	k <sub>4</sub>	l <sub>1</sub>	l <sub>2</sub> min.	F <sub>1</sub> ~	F <sub>2</sub> ~	min.	max.			[N]
<b>Med knopp och låsning – Bild 3</b>																					
4	12	–	19,0	22	6,0	3,3	4,0	7,0	14	4,0	8	7,0	33,0	4	3	12	-30	80	15	<a href="#">22110.2344</a>	
5	16	–	25,5	28	8,0	4,3	4,5	9,5	18	5,0	10	10,5	43,5	5	5	24	-30	80	30	<a href="#">22110.2345</a>	
6	18	–	30,5	32	10,0	5,4	5,0	10,5	21	5,5	12	13,0	52,0	6	5	21	-30	80	48	<a href="#">22110.2346</a>	
8	21	–	37,5	34	12,0	5,4	6,0	12,5	23	5,5	12	20,0	63,5	8	6	22	-30	80	68	<a href="#">22110.2348</a>	
10	25	–	40,0	39	14,5	6,5	6,0	14,5	27	6,0	15	18,5	72,5	10	4	25	-30	80	109	<a href="#">22110.2350</a>	

<sup>1)</sup> Statistiskt medelvärde

## Överensstämmelse

### RoHS-kompatibel

Överensstämmer med direktiv 2011/65/EU och direktiv 2015/863

### Innehåller inte SVHC-ämnen

Inga SVHC-ämnen med mer än 0,1 % w/w - SVHC-lista [REACH] per 27.06.2024.

### Innehåller inte ämnen i proposition 65

Inga Proposition 65-ämnen inkluderade  
<https://www.P65Warnings.ca.gov/>

### Fri från konfliktmineraler