

Centrerande spänndorn • cylindrisk

23340.0512



Produktbeskrivning

The centering clamping mandrels, cylindrical are ideal for use in fixture construction. They enable workpieces to be clamped with a hole on their inside diameter and therefore without interfering clamping edges. The centering clamping mandrels can be mounted on grid and fixture plates, for example, by pressing them into bores or screwing them into threads.

They enable exact positioning, offer precise repeat accuracy and achieve high holding forces when clamping parts with holes. The centering clamping mandrels offer the possibility of fixing complex workpieces without external clamping elements to enable these components to be machined on 5 sides.

The centering clamping mandrels, cylindrical have the following characteristics:

- Clamping stroke max. 0.7 mm
- Two versions - for press-in or screw-in
- Made of stainless steel or free-cutting steel
- Clamping body can be machined very easily (for adaptation to bore diameter)

Material

Kropp

- Automatstål

Spännskruv

- stål

Montering

The centering clamping mandrel can be adjusted to the respective diameter by turning or milling.

Picture 1 - Mounting in bore hole or socket.

Thread for clamping screw required.

Picture 2 – Mounting in thread.

Clamping screw for the mounting.

Remove from body.

Srew-in centering clamping elements and tighten using the wrench size (WS₂).

Drift

It is operated using the conical clamping screw (WS1). This expands the body by up to 0.7 mm.

Ritning

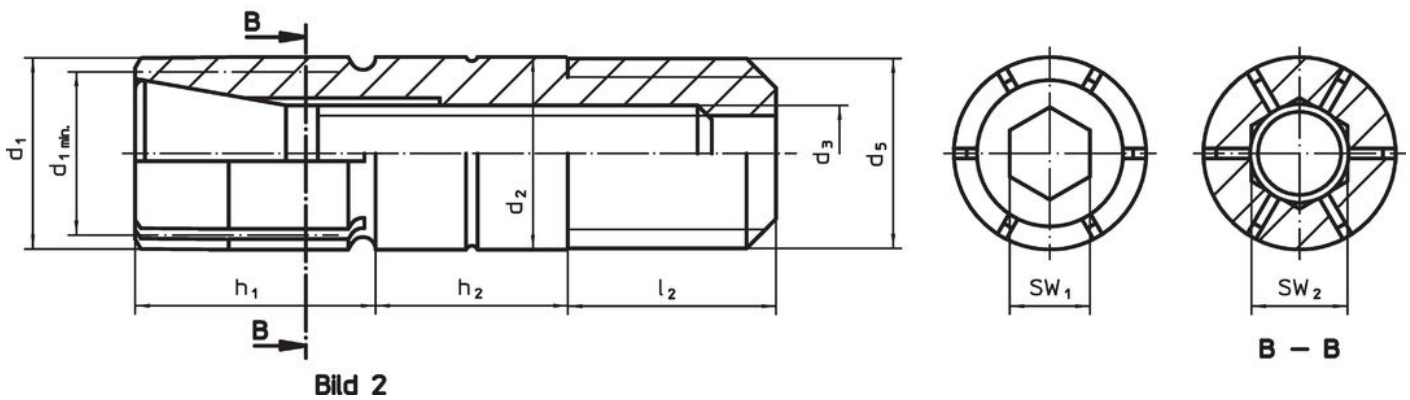
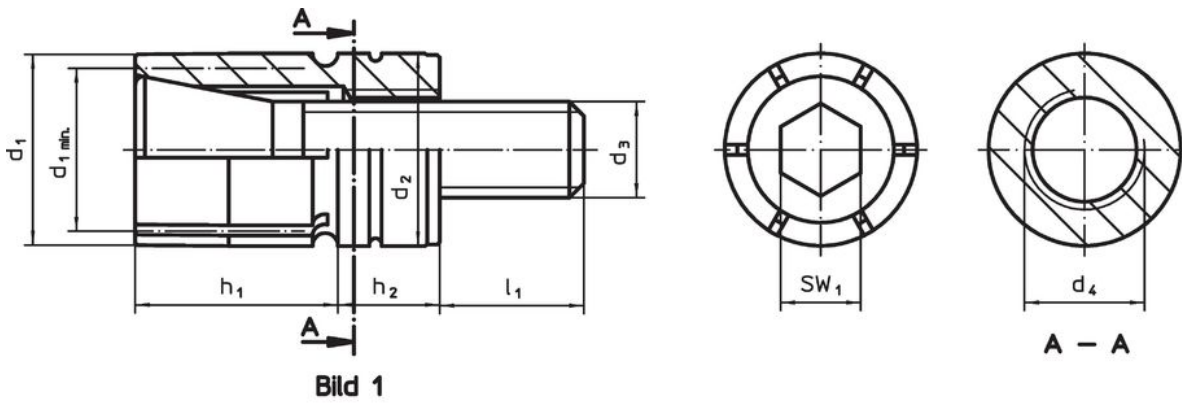

Orderinformation

d ₁	d ₁ min.	d ₂ -0,025	Dimension					SW SW ₁	Antal segment	Spännkraft max. [kN]	Åtdragnings moment max. [Nm]	Lokali- serings hål [mm]	[g]	Art.nr.
			d ₃	d ₄	h ₁	h ₂	l ₁							
press-fit – Bild 1, Automatstål														
12	10,5	12	M6	M8	12,7	6,35	11,1	5	6	8,5	17	12	17	23340.0512

Användningsexempel

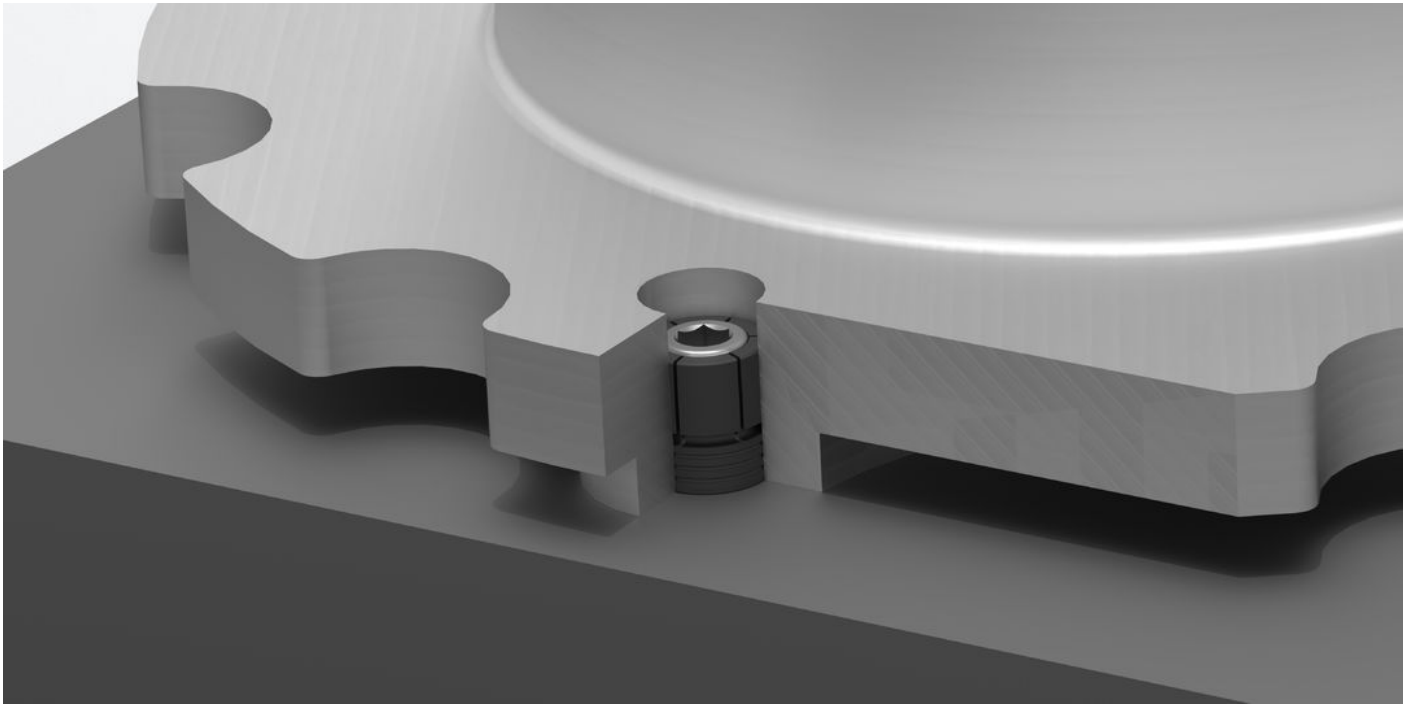

Överensstämmelse

RoHS-kompatibel

Överensstämmer med direktiv 2011/65/EU och direktiv 2015/863

Innehåller inte SVHC-ämnen

Inga SVHC-ämnen med mer än 0,1 % w/w - SVHC-lista [REACH] per 23.01.2024.

Innehåller inte ämnen i proposition 65

Inga Proposition 65-ämnen inkluderade
<https://www.P65Warnings.ca.gov/>

Fri från konfliktmineraler

Denna produkt innehåller inga ämnen betecknade som konfliktmineraler" såsom tantal, tenn, guld eller volfram från Demokratiska republiken Kongo eller angränsande länder."