

Hållare • till fjädrande tryckstift

22045.0008



Produktbeskrivning

Holders are used to mount spring plungers on the side. Ball-ended thrust screws, thrust screws, grub screws or similar can also be screwed into the thread.

The mounting thread is positioned 90° to the mounting direction in the holder. The slotted holes allow precise positioning of the holder during installation.

Material

- Stainless steel 1.4308, precision casting, matt blasted

Montering

Slotted holes are provided for mounting the holder. This allows it to be positioned precisely in the longitudinal direction. The mounting thread, e.g. for a spring plungers, is continuous. This means that a lock nut can be used to secure it after adjustment.

Ritning

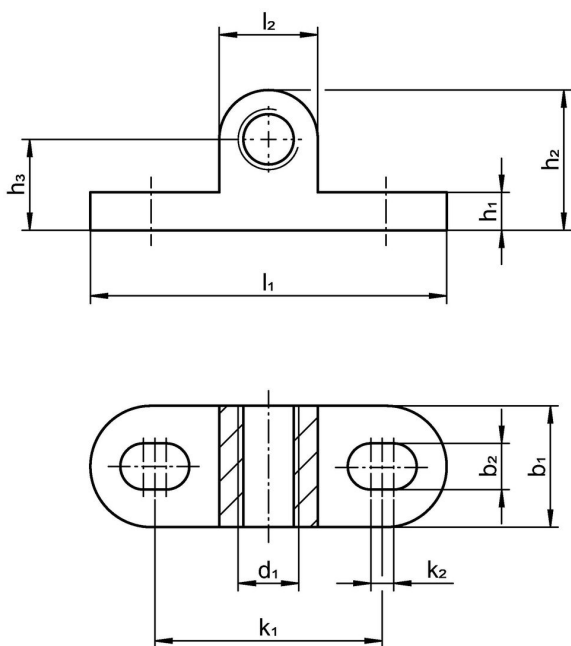

Orderinformation

d ₁	b ₁	b ₂	h ₁	Dimension						För bultar	[g]	Art.nr.		
				h ₂	h ₃	k ₁	k ₂	l ₁	l ₂					
[mm]												[mm]		
dubbelsidig														
M8	16	6	5	18,5	12	30	3	47	13	M6	35	22045.0008		

Överensstämmelse

RoHS-kompatibel

Överensstämmer med direktiv 2011/65/EU och direktiv 2015/863

Innehåller inte SVHC-ämnen

Inga SVHC-ämnen med mer än 0,1 % w/w - SVHC-lista [REACH] per 27.06.2024.

Innehåller inte ämnen i proposition 65

Inga Proposition 65-ämnen inkluderade
<https://www.P65Warnings.ca.gov/>

Fri från konfliktmineraler

Denna produkt innehåller inga ämnen betecknade som konfliktmineraler" såsom tantal, tenn, guld eller volfram från Demokratiska republiken Kongo eller angränsande länder."