

Bridă Pitbull® EH 23290.



Descrierea produsului

Pitbull® - pentru înălțimi de montare joase, cu o forță de prindere mare și efect de fixare pe masă. O-ringul servește la ridicarea bridei în momentul eliberării.

The knife edge version (picture 1) is especially suited for blanks.

The blunt edged version (picture 2) allows you to cover nearly all types of application. The version made of brass provides for clamping that is gentle, yet secure.

The Pitbull® Clamp with machinable edge (picture 3) has been designed with a machining add-on that allows for a contour to be milled into the workpiece. This version from hardened steel combines good machinability with excellent wear resistance.

The Pitbull® Clamps are distinguished by the following characteristics:

- space-saving design
- extra low construction height
- high clamping / tensioning force with pull-down effect
- ideal for multi-side machining and multiple clamping systems

Material

Clemă

- Oțel, călit
- Alamă
- Oțel, calit

Șurub

- Oțel tratat termic, călit

O-ring

- NBR

Mai multe informații

Note

The o-ring is used to lift the clamp off when it is released.

Desen



Figura 1



Figura 2

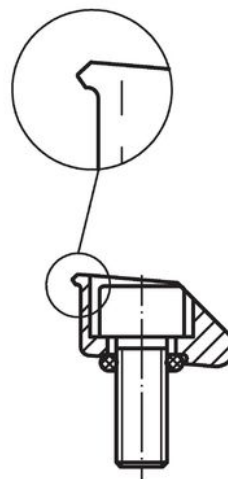
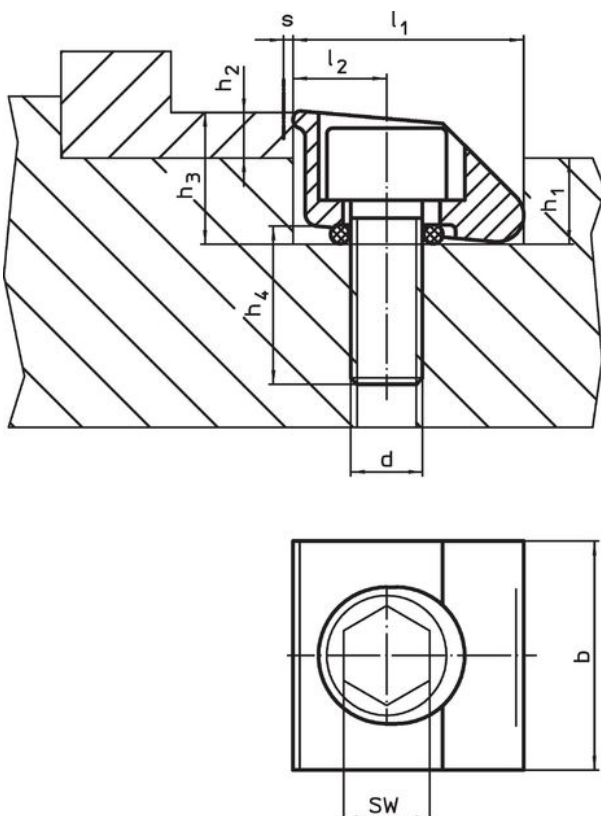

Figura 3

Informații comandă

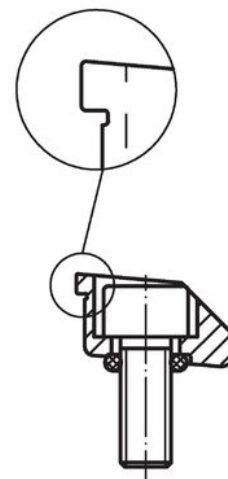
d	b	Dimensiuni								Distanța prindere s	SW	Forța de strângere max.	Moment strângere max.	Temperatură		Greutate	Ref. Nr.
		l ₁ H9	l ₂	l ₃	h ₁	h ₂ min.	h ₃ ~	h ₄ ~	min.					max.			
[mm]										[mm]	[kN]	[Nm]	[°C]		[g]		
cu cant ascuțit – figura 1, Oțel																	
M 4	12,7	12,70	5,10	–	4,8	2,6	7,4	8	0,4	3	2,6	6,0	-30	80	7,5	23290.0052	
M 6	19,1	19,05	7,60	–	7,1	3,8	10,9	11	0,6	5	8,0	17,0	-30	80	22,0	23290.0054	
M10	25,4	25,40	10,20	–	11,4	6,3	17,8	17	1,2	8	15,0	40,0	-30	80	66,0	23290.0056	
M12	38,1	38,10	15,20	–	16,3	9,5	25,8	21	1,9	10	25,0	120,0	-30	80	195,0	23290.0058	
muchie teșită – figura 2, Oțel																	
M 4	12,7	12,70	5,10	–	4,8	2,6	7,4	8	0,4	3	2,6	6,0	-30	80	6,2	23290.0062	
M 6	19,1	19,05	7,60	–	7,1	3,8	10,9	11	0,6	5	8,0	17,0	-30	80	22,0	23290.0064	
M10	25,4	25,40	10,20	–	11,4	6,3	17,8	17	1,2	8	15,0	40,0	-30	80	65,0	23290.0066	
M12	38,1	38,10	15,20	–	16,3	9,5	25,8	21	1,9	10	25,0	120,0	-30	80	201,0	23290.0068	
muchie teșită – figura 2, Alama																	
M 4	12,7	12,70	5,10	–	4,8	2,6	7,4	8	0,4	3	1,5	2,8	-30	80	7,3	23290.0204	
M 6	19,1	19,05	7,60	–	7,1	3,8	10,9	11	0,6	5	4,0	5,6	-30	80	23,0	23290.0206	
with machined edge; for form-fitting clamping – figura 3, Oțel, calit																	
M10	25,4	26,90	10,16	1,5	11,4	6,3	17,8	17	1,2	8	15,0	40,0	-30	80	71,0	23290.0310	
M12	38,1	42,60	15,24	4,5	16,3	9,5	25,8	21	1,9	10	25,0	120,0	-30	80	220,0	23290.0312	

Exemplu de aplicație

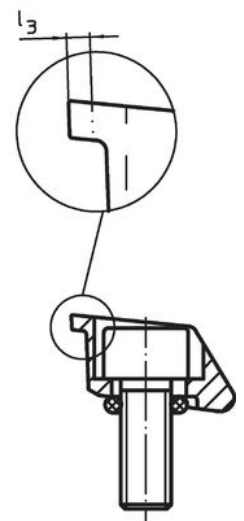
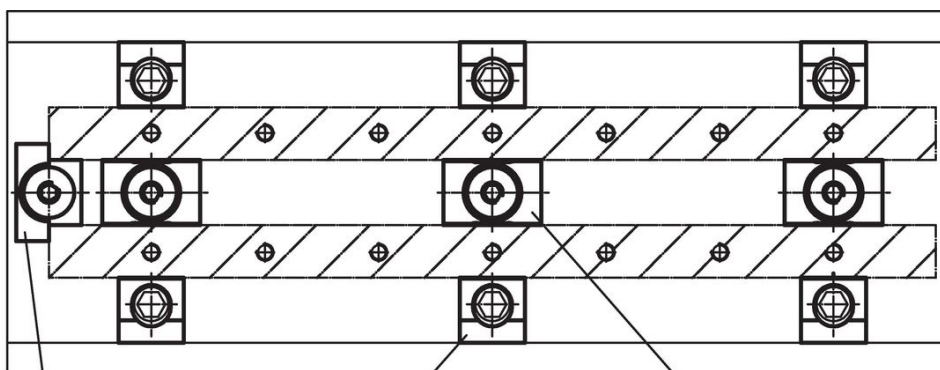
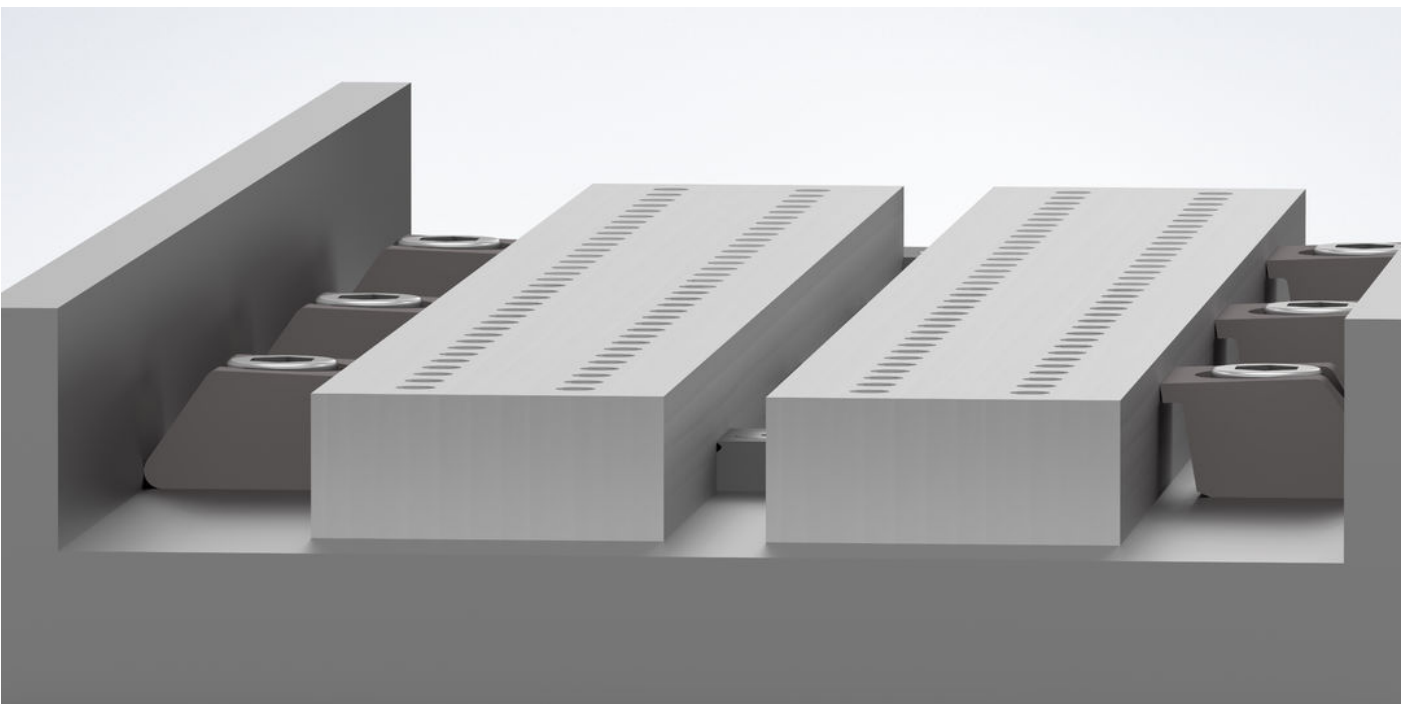

Opritor
23290.0104

Clemă Pitbull
ex. 23290.0052

Gheară de strângere
ex. 23290.0101

Reclamație

Conform RoHS

Sunt conforme Directivei 2011/65/UE și Directivei 2015/863.

Nu conțin materiale SVHC

Nu conține substanțe SVHC cu mai mult de 0,1% w/w - lista SVHC din 27.06.2024.

Nu conține substanțe din Declarația 65

Nu conține substanțe din Declarația 65.

<https://www.P65Warnings.ca.gov/>

Nu conține Minerale de conflict

Acest produs nu conține substanțe desemnate drept „minerale de conflict” precum tantalul, staniul, aurul sau wolfram din Republica Democratică Congo sau din țările adiacente.