

## Elemente de fixare cu excentric · with slot tenon

23270.0418



### Descrierea produsului

The eccentric clamping clamps can be used for quick and easy workpiece clamping directly on the machine table or a base plate with T-slots.

These eccentric clamping clamps with slot tenon are locked in a T-slot, for example on the machine table, with a thrust screw. Clamping takes place via the clamping screw with eccentric head. The brass basic element ensures gentle and secure clamping.

The eccentric clamping clamps with slot tenon have the following characteristics:

- Brass base element for material-friendly clamping
- Quick clamping thanks to clamping screw with eccentric head
- High clamping force is achieved
- Low design enables the machining of flat workpieces
- The compact dimensions enable space-saving multiple clamping

### Material

#### Șurub cu excentric

- Oțel

#### Știft filetat

- Oțel, brunat

#### Corp

- Alamă

#### Slot tenon

- Oțel, călit, brunat

### Mai multe informații

#### Note

The head of the eccentric screw can slightly protrude from the body ( $h_1$ ).

### Desen

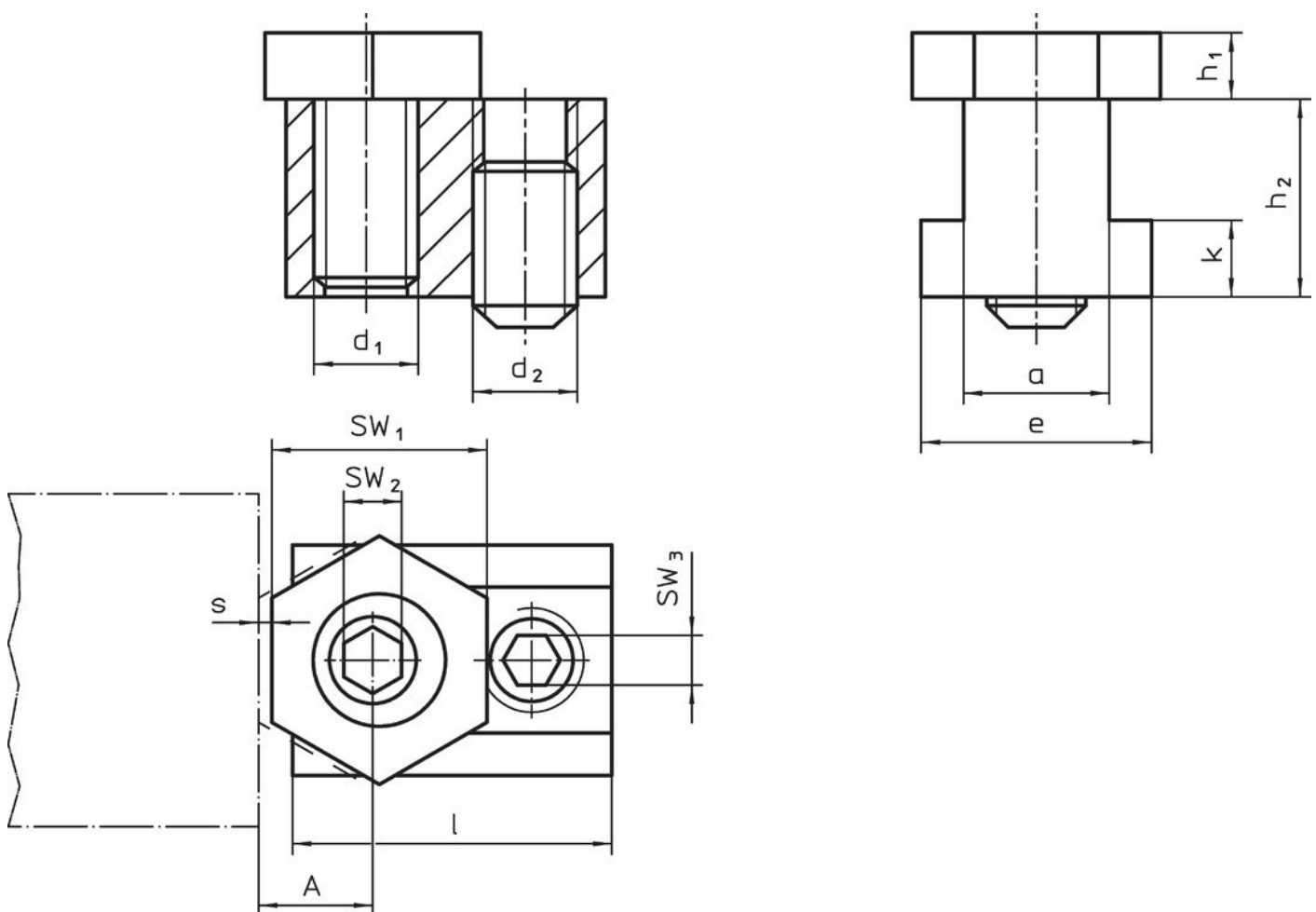

### Informații comandă

Mărimea nominală canal [mm]	d <sub>1</sub>	a	e	Dimensiuni						A	SW			Forța de strângere max. [kN]	Moment strângere SW <sub>2</sub> max. [Nm]	Moment strângere SW <sub>3</sub> max. [Nm]	Ref. Nr.
				h <sub>1</sub>	h <sub>2</sub>	k	s	l	SW <sub>1</sub>		SW <sub>2</sub>	SW <sub>3</sub>					
18	M12	17,7	28,5	9,5	28,5	10,5	2,5	34,7	12,7	25,4	8	6	9	75	55	190	23270.0418

### Exemplu de aplicație

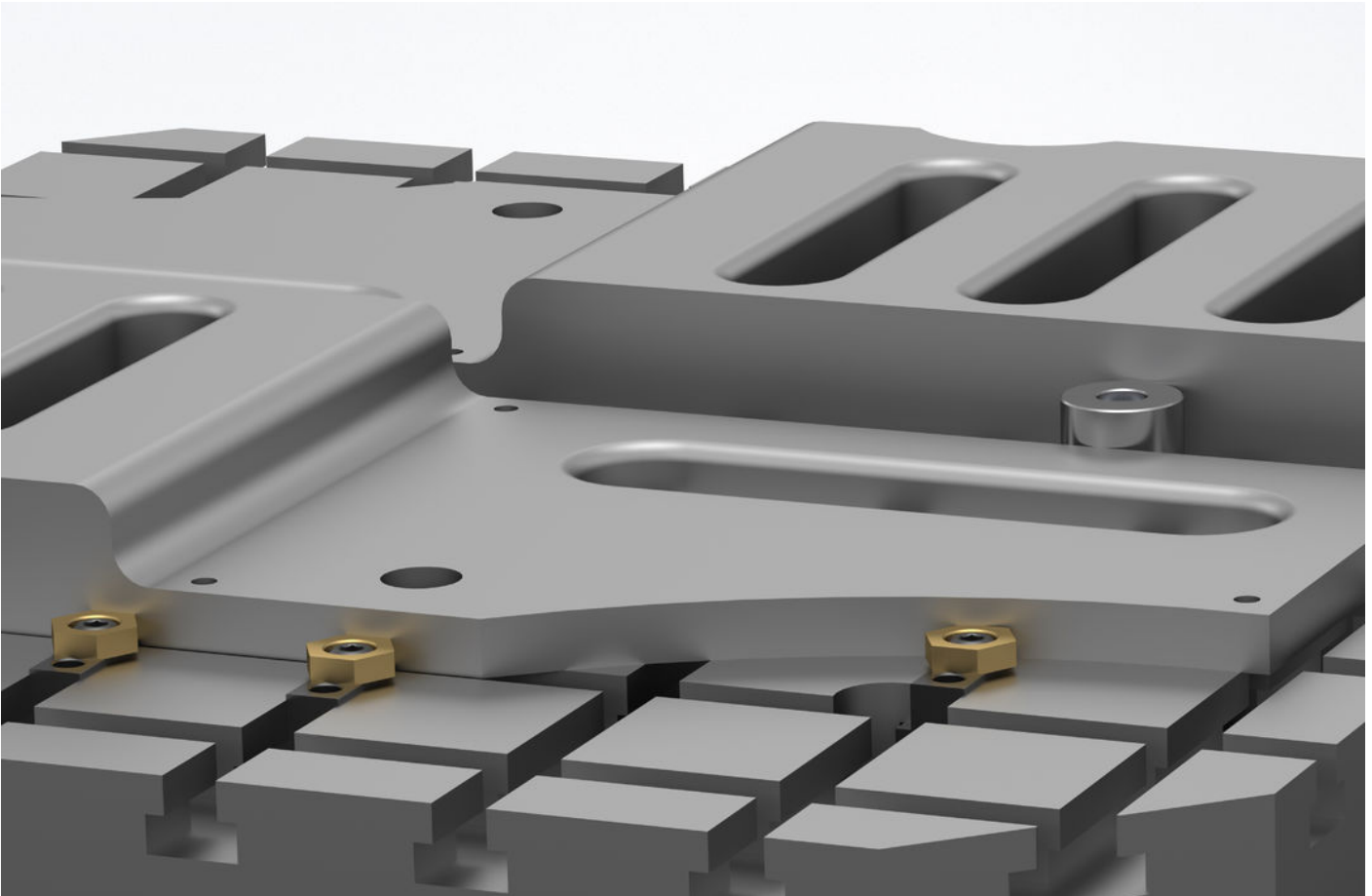

### Reclamație

Sunt conforme Directivei 2011/65/UE și Directivei 2015/863.

Nu conține substanțe SVHC cu mai mult de 0,1% w/w - lista SVHC din 27.06.2024.

Nu conține substanțe din Declarația 65.  
<https://www.P65Warnings.ca.gov/>