

Odbojniki gumowe · cylindryczne EH 25150.



Opis produktu

Stosowane jako odbojnik, stopka, itp.
Twardość $55 \pm 5^\circ$ shore A. Inne twardości ($40 \pm 5^\circ$ Shore A i $70 \pm 5^\circ$ Shore'a) na zapytanie.

Materiał

Podkładka

- Stal cynkowana galwanicznie, chromowana na niebiesko
- Stal nierdzewna 1.4301

Tuleja gwintowana

- Stal cynkowana galwanicznie, chromowana na niebiesko
- Stal nierdzewna 1.4301

Korpus

- Kauczuk naturalny (NR), czarny

Śruba

- Stal cynkowana galwanicznie, chromowana na niebiesko
- Stal nierdzewna 1.4301

Więcej informacji

Inne produkty

- Stopy podporowe, Tłumiące drgania

Rysunek

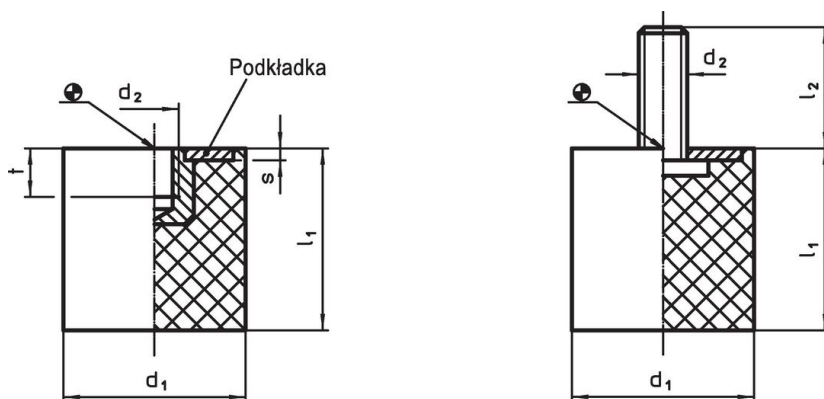





Rysunek 1

Rysunek 2

Informacje do zamówienia

Wymiary						Siła sprężyny R ~ [N/mm]	Obciążalność maks. [N]	Droga sprężynowania ~ [mm]	Temperatura		Ciężar [g]	Nr art.
d ₁	l ₁	d ₂	l ₂	s	t				min.	maks.		
[mm]												
z gwintem wewnętrznym – rysunek 1, Stal												
10	10	M 4	–	1,2	4,0	24	59	2,50	-30	80	1,7	25150.0306
15	15	M 4	–	1,4	4,0	64	241	3,75	-30	80	4,6	25150.0309
15	20	M 4	–	1,4	4,0	57	287	5,00	-30	80	5,7	25150.0310
20	15	M 6	–	2,0	5,0	77	289	3,75	-30	80	10,0	25150.0321
20	20	M 6	–	2,0	5,0	60	302	5,00	-30	80	10,0	25150.0322
20	25	M 6	–	2,0	5,0	48	297	6,25	-30	80	13,0	25150.0323
25	15	M 6	–	2,0	5,0	163	612	3,75	-30	80	14,0	25150.0326
25	20	M 6	–	2,0	5,0	112	560	5,00	-30	80	20,0	25150.0327
25	30	M 6	–	2,0	5,0	68	509	7,50	-30	80	20,0	25150.0328
30	15	M 8	–	2,0	6,5	294	934	3,75	-30	80	20,0	25150.0331
30	20	M 8	–	2,0	6,5	185	924	5,00	-30	80	30,0	25150.0332
30	30	M 8	–	2,0	6,5	117	876	7,50	-30	80	30,0	25150.0333
40	20	M 8	–	2,0	6,5	247	1235	5,00	-30	80	50,0	25150.0341
40	30	M 8	–	2,0	6,5	213	1600	7,50	-30	80	55,0	25150.0342
40	40	M 8	–	2,0	6,5	182	1820	10,00	-30	80	80,0	25150.0343

Wymiary						Siła sprężyny R ~ [N/mm]	Obciążalność maks. [N]	Droga sprężynowania ~ [mm]	 min. maks. [°C]		 [g]	Nr art.
d ₁	l ₁	d ₂	l ₂	s	t ~				[mm]			
50	20	M10	-	2,0	7,0	517	2587	5,00	-30	80	80,0	25150.0351
50	30	M10	-	2,0	7,0	327	2453	7,50	-30	80	100,0	25150.0352
50	40	M10	-	2,0	7,0	247	2468	10,00	-30	80	120,0	25150.0353
60	30	M10	-	2,0	7,0	467	3500	7,50	-30	80	140,0	25150.0361
60	50	M10	-	2,0	7,0	269	3367	12,50	-30	80	210,0	25150.0362
70	40	M10	-	3,0	7,0	410	4100	10,00	-30	80	260,0	25150.0371
70	55	M10	-	3,0	7,0	327	4500	13,75	-30	80	340,0	25150.0372
75	30	M12	-	3,0	9,0	600	4500	7,50	-30	80	210,0	25150.0376
75	40	M12	-	3,0	9,0	450	4500	10,00	-30	80	290,0	25150.0377
75	50	M12	-	3,0	9,0	352	4400	12,50	-30	80	350,0	25150.0378
100	40	M16	-	3,0	16,0	810	8100	10,00	-30	80	514,0	25150.0382
100	50	M16	-	3,0	16,0	640	8000	12,50	-30	80	512,0	25150.0384
100	60	M16	-	3,0	16,0	520	7800	15,00	-30	80	698,0	25150.0386
ze śrubą – rysunek 2, Stal												
8	8	M 3	6	1,0	-	20	40	2,00	-30	80	1,0	25150.0403
10	10	M 4	10	1,2	-	24	59	2,50	-30	80	1,9	25150.0406
10	15	M 4	10	1,2	-	21	78	3,75	-30	80	2,4	25150.0407
15	10	M 4	10	1,4	-	77	154	2,00	-30	80	4,0	25150.0408
15	15	M 4	10	1,4	-	64	241	3,75	-30	80	5,0	25150.0409
15	20	M 4	10	1,4	-	57	287	5,00	-30	80	6,2	25150.0410
15	30	M 4	10	1,4	-	48	300	6,25	-30	80	8,0	25150.0411
20	10	M 6	18	2,0	-	126	315	2,50	-30	80	10,0	25150.0421
20	15	M 6	18	2,0	-	77	289	3,75	-30	80	10,0	25150.0422
20	20	M 6	18	2,0	-	60	302	5,00	-30	80	13,0	25150.0423
20	30	M 6	18	2,0	-	38	285	7,50	-30	80	20,0	25150.0424
25	15	M 6	18	2,0	-	163	612	3,75	-30	80	18,0	25150.0426
25	20	M 6	18	2,0	-	112	560	5,00	-30	80	20,0	25150.0427
25	30	M 6	18	2,0	-	68	509	7,50	-30	80	25,0	25150.0428
30	15	M 8	20	2,0	-	294	934	3,75	-30	80	28,0	25150.0431
30	20	M 8	20	2,0	-	185	924	5,00	-30	80	32,0	25150.0432
30	25	M 8	20	2,0	-	130	815	6,25	-30	80	38,0	25150.0433
30	30	M 8	20	2,0	-	117	876	7,50	-30	80	43,0	25150.0434
40	20	M 8	23	2,0	-	247	1235	5,00	-30	80	55,0	25150.0441
40	25	M 8	23	2,0	-	247	1546	6,25	-30	80	60,0	25150.0442
40	30	M 8	23	2,0	-	213	1600	7,50	-30	80	73,0	25150.0443
40	40	M 8	23	2,0	-	182	1820	10,00	-30	80	83,0	25150.0444
50	20	M10	28	2,0	-	517	2587	5,00	-30	80	90,0	25150.0451
50	30	M10	28	2,0	-	327	2453	7,50	-30	80	118,0	25150.0452
50	40	M10	28	2,0	-	247	2468	10,00	-30	80	140,0	25150.0453
60	20	M10	28	2,0	-	726	3630	5,00	-30	80	110,0	25150.0461
60	40	M10	28	2,0	-	340	3400	10,00	-30	80	195,0	25150.0462
70	40	M10	27	3,0	-	410	4100	10,00	-30	80	265,0	25150.0471
70	55	M10	27	3,0	-	327	4500	13,75	-30	80	357,0	25150.0472
75	25	M12	37	3,0	-	752	4700	6,25	-30	80	223,0	25150.0476
75	40	M12	37	3,0	-	450	4500	10,00	-30	80	310,0	25150.0477
75	50	M12	37	3,0	-	352	4400	12,50	-30	80	340,0	25150.0478
100	40	M16	41	3,0	-	810	8100	10,00	-30	80	570,0	25150.0482
100	50	M16	41	3,0	-	640	8000	12,50	-30	80	656,0	25150.0484
100	60	M16	41	3,0	-	520	7800	15,00	-30	80	750,0	25150.0486
z gwintem wewnętrznym – rysunek 1, Stal nierdzewna												
10	10	M 4	-	1,2	4,0	24	59	2,50	-30	80	1,7	25150.1306
15	15	M 4	-	1,4	4,0	64	241	3,75	-30	80	4,6	25150.1309
15	20	M 4	-	1,4	4,0	57	287	5,00	-30	80	5,7	25150.1310
20	15	M 6	-	2,0	5,0	77	289	3,75	-30	80	10,0	25150.1321
20	20	M 6	-	2,0	5,0	60	302	5,00	-30	80	10,0	25150.1322
20	25	M 6	-	2,0	5,0	48	297	6,25	-30	80	13,0	25150.1323
25	15	M 6	-	2,0	5,0	163	612	3,75	-30	80	14,0	25150.1326
25	20	M 6	-	2,0	5,0	112	560	5,00	-30	80	20,0	25150.1327
25	30	M 6	-	2,0	5,0	68	509	7,50	-30	80	20,0	25150.1328
30	15	M 8	-	2,0	6,5	294	934	3,75	-30	80	20,0	25150.1331
30	20	M 8	-	2,0	6,5	185	924	5,00	-30	80	30,0	25150.1332

Wymiary						Siła sprężyny R ~ [N/mm]	Obciążalność maks. [N]	Droga sprężynowania ~ [mm]	 min. maks. [°C]		 [g]	Nr art.
d ₁	l ₁	d ₂	l ₂	s	t ~				[mm]			
30	30	M 8	-	2,0	6,5	117	876	7,50	-30	80	30,0	25150.1333
40	20	M 8	-	2,0	6,5	247	1235	5,00	-30	80	50,0	25150.1341
40	30	M 8	-	2,0	6,5	213	1600	7,50	-30	80	55,0	25150.1342
40	40	M 8	-	2,0	6,5	182	1820	10,00	-30	80	80,0	25150.1343
50	20	M10	-	2,0	7,0	517	2587	5,00	-30	80	80,0	25150.1351
50	30	M10	-	2,0	7,0	327	2453	7,50	-30	80	100,0	25150.1352
50	40	M10	-	2,0	7,0	247	2468	10,00	-30	80	120,0	25150.1353
60	30	M10	-	2,0	7,0	467	3500	7,50	-30	80	140,0	25150.1361
60	50	M10	-	2,0	7,0	269	3367	12,50	-30	80	210,0	25150.1362
70	40	M10	-	3,0	7,0	410	4100	10,00	-30	80	260,0	25150.1371
70	55	M10	-	3,0	7,0	327	4500	13,75	-30	80	340,0	25150.1372
75	30	M12	-	3,0	9,0	600	4500	7,50	-30	80	210,0	25150.1376
75	40	M12	-	3,0	9,0	450	4500	10,00	-30	80	290,0	25150.1377
75	50	M12	-	3,0	9,0	352	4400	12,50	-30	80	350,0	25150.1378
100	40	M16	-	3,0	16,0	810	8100	10,00	-30	80	514,0	25150.1382
100	50	M16	-	3,0	16,0	640	8000	12,50	-30	80	512,0	25150.1384
100	60	M16	-	3,0	16,0	520	7800	15,00	-30	80	698,0	25150.1386
ze śrubą – rysunek 2, Stal nierdzewna												
8	8	M 3	6	1,0	-	20	40	2,00	-30	80	1,0	25150.1403
10	10	M 4	10	1,2	-	24	59	2,50	-30	80	1,9	25150.1406
10	15	M 4	10	1,2	-	21	78	3,75	-30	80	2,4	25150.1407
15	10	M 4	10	1,4	-	77	154	2,00	-30	80	4,0	25150.1408
15	15	M 4	10	1,4	-	64	241	3,75	-30	80	5,0	25150.1409
15	20	M 4	10	1,4	-	57	287	5,00	-30	80	6,2	25150.1410
15	30	M 4	10	1,4	-	48	300	6,25	-30	80	8,0	25150.1411
20	10	M 6	18	2,0	-	126	315	2,50	-30	80	10,0	25150.1421
20	15	M 6	18	2,0	-	77	289	3,75	-30	80	10,0	25150.1422
20	20	M 6	18	2,0	-	60	302	5,00	-30	80	13,0	25150.1423
20	30	M 6	18	2,0	-	38	285	7,50	-30	80	20,0	25150.1424
25	15	M 6	18	2,0	-	163	612	3,75	-30	80	18,0	25150.1426
25	20	M 6	18	2,0	-	112	560	5,00	-30	80	20,0	25150.1427
25	30	M 6	18	2,0	-	68	509	7,50	-30	80	25,0	25150.1428
30	15	M 8	20	2,0	-	294	934	3,75	-30	80	28,0	25150.1431
30	20	M 8	20	2,0	-	185	924	5,00	-30	80	32,0	25150.1432
30	25	M 8	20	2,0	-	130	815	6,25	-30	80	38,0	25150.1433
30	30	M 8	20	2,0	-	117	876	7,50	-30	80	43,0	25150.1434
40	20	M 8	23	2,0	-	247	1235	5,00	-30	80	55,0	25150.1441
40	25	M 8	23	2,0	-	247	1546	6,25	-30	80	60,0	25150.1442
40	30	M 8	23	2,0	-	213	1600	7,50	-30	80	73,0	25150.1443
40	40	M 8	23	2,0	-	182	1820	10,00	-30	80	83,0	25150.1444
50	20	M10	28	2,0	-	517	2587	5,00	-30	80	90,0	25150.1451
50	30	M10	28	2,0	-	327	2453	7,50	-30	80	118,0	25150.1452
50	40	M10	28	2,0	-	247	2468	10,00	-30	80	140,0	25150.1453
60	20	M10	28	2,0	-	726	3630	5,00	-30	80	110,0	25150.1461
60	40	M10	28	2,0	-	340	3400	10,00	-30	80	195,0	25150.1462
70	40	M10	27	3,0	-	410	4100	10,00	-30	80	265,0	25150.1471
70	55	M10	27	3,0	-	327	4500	13,75	-30	80	357,0	25150.1472
75	25	M12	37	3,0	-	752	4700	6,25	-30	80	223,0	25150.1476
75	40	M12	37	3,0	-	450	4500	10,00	-30	80	310,0	25150.1477
75	50	M12	37	3,0	-	352	4400	12,50	-30	80	340,0	25150.1478
100	40	M16	41	3,0	-	810	8100	10,00	-30	80	570,0	25150.1482
100	50	M16	41	3,0	-	640	8000	12,50	-30	80	656,0	25150.1484
100	60	M16	41	3,0	-	520	7800	15,00	-30	80	750,0	25150.1486

Przykład aplikacji

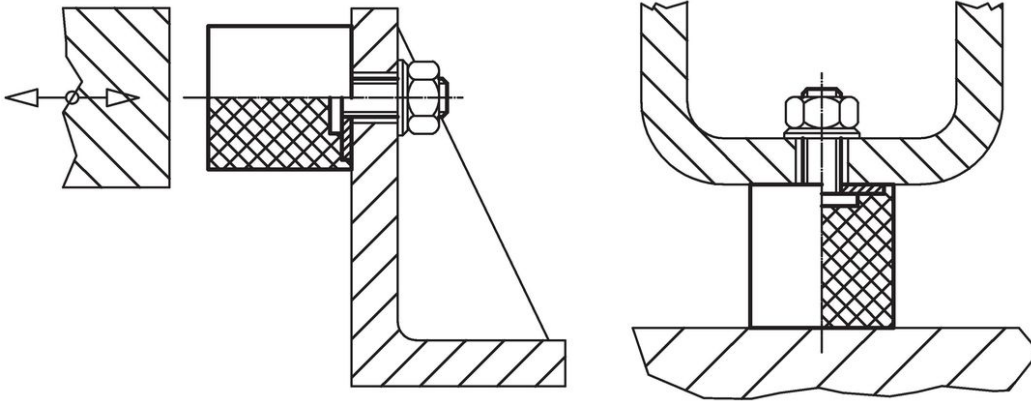

Zgodność

Dla szczegółowych informacji dot. zgodności należy wybrać pożądany numer towaru.