

Sworznie EH 22690.



Opis produktu

Nadają się do zastosowania jako podkładki, ograniczniki i elementy dociskowe.

Materiał

- Stal utwardzana dyspersyjnie, oksydowana

Więcej informacji

Inne produkty

- Sworznie podporowe, z rowkami lub szpicem
- Sworznie, z plastikową powierzchnią styku

Rysunek

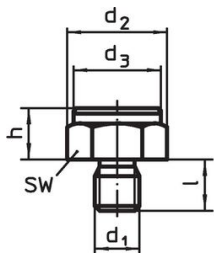

rysunek 1

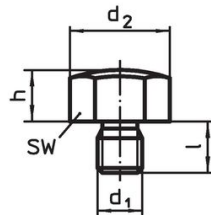

rysunek 2

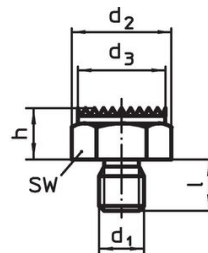

rysunek 3

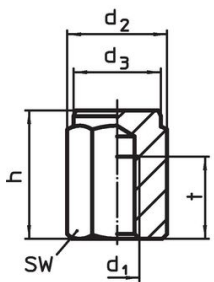

rysunek 4

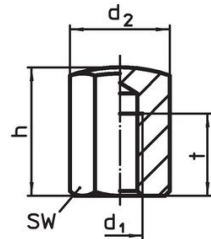

rysunek 5

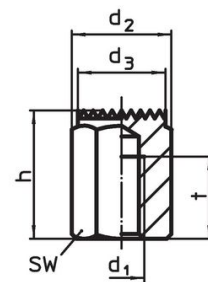

rysunek 6

Informacje do zamówienia

h	d ₁	Wymiary				SW	Moment dociągający maks.		Nr art.
		d ₂	d ₃	l	t	[mm]	[Nm]	[g]	
[mm]									
z gwintem zewnętrznym i gładką powierzchnią przyłożenia – rysunek 1									
10 ±0,01	M 8	19,4	17	10	–	17	18	21	22690.0021
10 ±0,01	M10	21,9	19	12	–	19	32	28	22690.0031
15 ±0,01	M10	21,9	19	12	–	19	32	40	22690.0032
10 ±0,01	M12	25,2	22	14	–	22	60	40	22690.0001
15 ±0,01	M12	25,2	22	14	–	22	60	55	22690.0002
15 ±0,01	M16	33,0	30	19	–	30	140	110	22690.0042
20 ±0,01	M16	33,0	30	19	–	30	140	140	22690.0043
20 ±0,01	M20	40,0	36	24	–	36	290	214	22690.0052
25 ±0,01	M20	40,0	36	24	–	36	290	257	22690.0053
20 ±0,01	M24	46,0	41	29	–	41	498	300	22690.0062
25 ±0,01	M24	46,0	41	29	–	41	498	356	22690.0063
30 ±0,01	M24	46,0	41	29	–	41	498	412	22690.0064

¹⁾ Momenty dociągu bolców z gwintem wewn. jak dla bolców klasy 8. Gwint należy wkręcić na całej długości.

h	d ₁	Wymiary				t	SW	Moment dociągający maks. [Nm]		Nr art.
		d ₂	d ₃	l	[mm]					
z gwintem zewnętrznym i wypukłą powierzchnią przyłożenia – rysunek 2										
10 ±0,10	M 8	19,4	–	10	–	17	18	20	22690.0121	
10 ±0,10	M10	21,9	–	12	–	19	32	27	22690.0131	
15 ±0,10	M10	21,9	–	12	–	19	32	40	22690.0132	
10 ±0,10	M12	25,2	–	14	–	22	60	37	22690.0101	
15 ±0,10	M12	25,2	–	14	–	22	60	53	22690.0102	
15 ±0,10	M16	33,0	–	19	–	30	140	105	22690.0142	
20 ±0,10	M16	33,0	–	19	–	30	140	135	22690.0143	
20 ±0,10	M20	40,0	–	24	–	36	290	206	22690.0152	
25 ±0,10	M20	40,0	–	24	–	36	290	249	22690.0153	
20 ±0,10	M24	46,0	–	29	–	41	498	285	22690.0162	
25 ±0,10	M24	46,0	–	29	–	41	498	342	22690.0163	
30 ±0,10	M24	46,0	–	29	–	41	498	398	22690.0164	
z gwintem zewnętrznym i żłobkową powierzchnią przyłożenia – rysunek 3										
10 ±0,10	M 8	19,4	17	10	–	17	18	20	22690.0221	
10 ±0,10	M10	21,9	19	12	–	19	32	27	22690.0231	
15 ±0,10	M10	21,9	19	12	–	19	32	39	22690.0232	
10 ±0,10	M12	25,2	22	14	–	22	60	38	22690.0201	
15 ±0,10	M12	25,2	22	14	–	22	60	54	22690.0202	
15 ±0,10	M16	33,0	30	19	–	30	140	106	22690.0242	
20 ±0,10	M16	33,0	30	19	–	30	140	136	22690.0243	
20 ±0,10	M20	40,0	36	24	–	36	290	200	22690.0252	
25 ±0,10	M20	40,0	36	24	–	36	290	243	22690.0253	
20 ±0,10	M24	46,0	41	29	–	41	498	282	22690.0262	
25 ±0,10	M24	46,0	41	29	–	41	498	338	22690.0263	
30 ±0,10	M24	46,0	41	29	–	41	498	395	22690.0264	
z gwintem wewnętrznym i gładką powierzchnią przyłożenia w tolerancji I₁ = ±0,01 – rysunek 4										
15 ±0,01	M 8	19,4	17	15	6	17	25 ¹⁾	25	22690.0321	
25 ±0,01	M 8	19,4	17	25	12	17	25 ¹⁾	42	22690.0323	
20 ±0,01	M10	21,9	19	20	10	19	46 ¹⁾	40	22690.0333	
30 ±0,01	M10	21,9	19	30	15	19	46 ¹⁾	61	22690.0335	
40 ±0,01	M10	21,9	19	40	15	19	46 ¹⁾	85	22690.0337	
20 ±0,01	M12	25,2	22	20	10	22	82 ¹⁾	52	22690.0301	
25 ±0,01	M12	25,2	22	25	15	22	82 ¹⁾	65	22690.0302	
30 ±0,01	M12	25,2	22	30	18	22	82 ¹⁾	79	22690.0303	
40 ±0,01	M12	25,2	22	40	18	22	82 ¹⁾	111	22690.0304	
50 ±0,01	M12	25,2	22	50	18	22	82 ¹⁾	142	22690.0305	
30 ±0,01	M16	33,0	30	30	20	30	206 ¹⁾	141	22690.0343	
50 ±0,01	M16	33,0	30	50	24	30	206 ¹⁾	256	22690.0345	
40 ±0,01	M20	40,0	36	40	26	36	407 ¹⁾	268	22690.0353	
60 ±0,01	M20	40,0	36	60	38	36	407 ¹⁾	415	22690.0355	
40 ±0,01	M24	46,0	41	40	26	41	698 ¹⁾	341	22690.0363	
60 ±0,01	M24	46,0	41	60	38	41	698 ¹⁾	530	22690.0365	
z gwintem wewnętrznym i wypukłą powierzchnią przyłożenia – rysunek 5										
15 ±0,10	M 8	19,4	–	15	6	17	25 ¹⁾	24	22690.0421	
25 ±0,10	M 8	19,4	–	25	12	17	25 ¹⁾	41	22690.0423	
20 ±0,10	M10	21,9	–	20	10	19	46 ¹⁾	38	22690.0433	
30 ±0,10	M10	21,9	–	30	15	19	46 ¹⁾	60	22690.0435	
40 ±0,10	M10	21,9	–	40	15	19	46 ¹⁾	84	22690.0437	
20 ±0,10	M12	25,2	–	20	10	22	82 ¹⁾	50	22690.0401	
25 ±0,10	M12	25,2	–	25	15	22	82 ¹⁾	62	22690.0402	
30 ±0,10	M12	25,2	–	30	18	22	82 ¹⁾	76	22690.0403	
40 ±0,10	M12	25,2	–	40	18	22	82 ¹⁾	109	22690.0404	

¹⁾ Momenty dociągu bolców z gwintem wewn. jak dla bolców klasy 8. Gwint należy wkręcić na całej długości.

h	d ₁	Wymiary				t	SW [mm]	Moment dociągający maks. [Nm]	 [g]	Nr art.
		d ₂	d ₃	l	[mm]					
50 ±0,10	M12	25,2	–	50	18	22	82 ¹⁾	141	22690.0405	
30 ±0,10	M16	33,0	–	30	20	30	206 ¹⁾	136	22690.0443	
50 ±0,10	M16	33,0	–	50	24	30	206 ¹⁾	252	22690.0445	
40 ±0,10	M20	40,0	–	40	26	36	407 ¹⁾	261	22690.0453	
60 ±0,10	M20	40,0	–	60	38	36	407 ¹⁾	408	22690.0455	
40 ±0,10	M24	46,0	–	40	26	41	698 ¹⁾	327	22690.0463	
60 ±0,10	M24	46,0	–	60	38	41	698 ¹⁾	514	22690.0465	
z gwintem wewnętrznym i żłobkową powierzchnią przyłożenia – rysunek 6										
15 ±0,10	M 8	19,4	17	15	6	17	25 ¹⁾	24	22690.0521	
25 ±0,10	M 8	19,4	17	25	12	17	25 ¹⁾	41	22690.0523	
20 ±0,10	M10	21,9	19	20	10	19	46 ¹⁾	38	22690.0533	
30 ±0,10	M10	21,9	19	30	15	19	46 ¹⁾	60	22690.0535	
40 ±0,10	M10	21,9	19	40	15	19	46 ¹⁾	84	22690.0537	
20 ±0,10	M12	25,2	22	20	10	22	82 ¹⁾	50	22690.0501	
25 ±0,10	M12	25,2	22	25	15	22	82 ¹⁾	63	22690.0502	
30 ±0,10	M12	25,2	22	30	18	22	82 ¹⁾	77	22690.0503	
40 ±0,10	M12	25,2	22	40	18	22	82 ¹⁾	109	22690.0504	
50 ±0,10	M12	25,2	22	50	18	22	82 ¹⁾	141	22690.0505	
30 ±0,10	M16	33,0	30	30	20	30	206 ¹⁾	137	22690.0543	
50 ±0,10	M16	33,0	30	50	24	30	206 ¹⁾	254	22690.0545	
40 ±0,10	M20	40,0	36	40	26	36	407 ¹⁾	254	22690.0553	
60 ±0,10	M20	40,0	36	60	38	36	407 ¹⁾	401	22690.0555	
40 ±0,10	M24	46,0	41	40	26	41	698 ¹⁾	322	22690.0563	
60 ±0,10	M24	46,0	41	60	38	41	698 ¹⁾	408	22690.0565	

¹⁾ Momenty dociągu bolców z gwintem wewn. jak dla bolców klasy 8. Gwint należy wkręcić na całej długości.

Przykład aplikacji

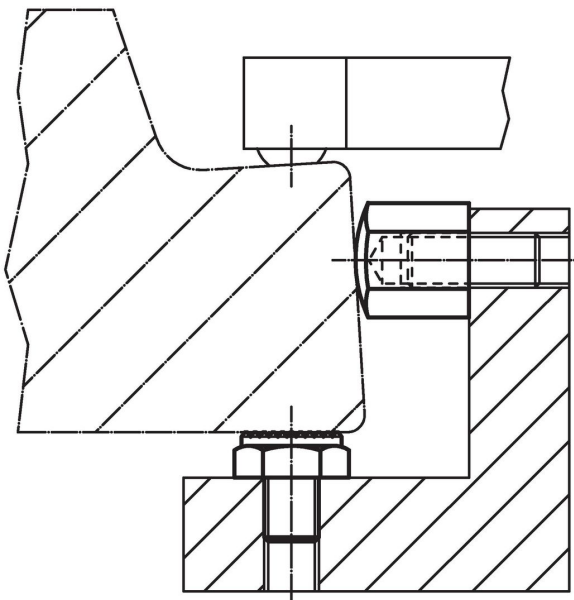

Zgodność

Zgodny z RoHS

Zawiera ołów - zgodny z wyjątkami 6a /6b /6c

Zawiera substancje SVHC > 0,1% mas.

Zawiera ołów – lista SVHC [REACH] z dnia 27.06.2024.

Zawiera substancje z Propozycja 65



Kontakt z ołowiem może powodować raka i bezpłodność
<https://www.P65Warnings.ca.gov/>

Wolny od minerałów konfliktu

Ten produkt nie zawiera żadnych substancji oznaczonych jako „minerały konfliktu”, takich jak tantal, cyna, złoto lub wolfram z Demokratycznej Republiki Konga lub krajów sąsiednich.