

As-naaf spansets • zonder borgmoer

EH 25050.

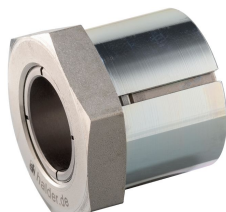

Productbeschrijving

Met deze spansets kunnen alle as-naaf-verbindingen van machine elementen, zoals kettingwielen, tandwielen, riemschijven, nokken, hefboomen etc., eenvoudig en tegen lage kosten geproduceerd worden.

Hierbij gaat het om een zelfcentrerende en spelingvrije as-naaf-spanset in een corrosiewerende uitvoering met een buitenzeskant.

De rotatienauwkeurigheid van de as-naaf-spanset is 0,03 mm.

Materiaal

Buitendeel

- staal, galvanisch verzinkt

Binnendeel

- staal, vernikkeld

Moer

- staal, vernikkeld

Meer informatie

Verwijzingen

Volg de montage-instructies, montagevoorbeelden en technische gegevens op.

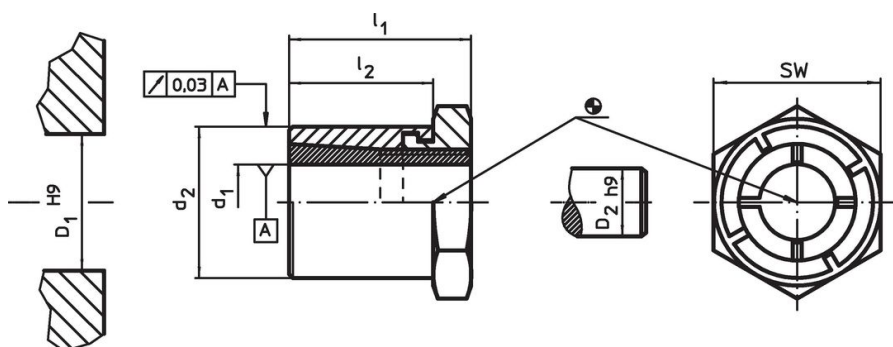

Tekening



Bestelinformatie

Afmetingen				SW	Aandraai moment moer	Overdraagbaar koppel	Overdraagbare axiale belasting	Oppervlaktedruk op de as	Oppervlaktedruk van de naaf	Naaf boring	Asdiameter	Artikelnr.	
d ₁	d ₂	l ₁	l ₂		T _A max.	M max.	F _a max.	p _w max.	p _N max.	D ₁ H9	D ₂ h9		
[mm]				[mm]	[Nm]	[Nm]	[kN]	[N/mm ²]	[N/mm ²]	[mm]	[mm]	[g]	
5	14	19	15	14	9,9	10,1	4,0	264	96	14	5	18	25050.0005
6	14	19	15	14	9,9	12,1	4,0	220	96	14	6	17	25050.0006
8	16	22	17	16	16,9	23,4	5,8	179	91	16	8	24	25050.0008
9	20	24	19	22	34,9	43,7	9,7	245	115	20	9	47	25050.0009
10	20	24	19	22	34,9	48,6	9,7	221	115	20	10	45	25050.0010
11	22	24	19	22	43,8	59,9	10,9	225	117	22	11	51	25050.0011
12	22	24	19	22	43,8	65,3	10,9	206	117	22	12	47	25050.0012
14	26	28	22	27	65,0	93,0	13,3	178	99	26	14	81	25050.0014
15	26	28	22	27	65,0	99,0	13,3	166	99	26	15	76	25050.0015
16	26	28	22	27	65,0	106,0	13,3	156	99	26	16	71	25050.0016
18	35	36	27	36	161,0	223,0	24,8	224	125	35	18	197	25050.0018
19	35	36	27	36	161,0	235,0	24,8	212	125	35	19	190	25050.0019
20	35	36	27	36	161,0	248,0	24,8	201	125	35	20	181	25050.0020
22	42	41	30	46	250,0	349,0	31,8	197	110	42	22	344	25050.0022
24	42	41	30	46	250,0	381,0	31,8	180	110	42	24	322	25050.0024
25	42	41	30	46	250,0	397,0	31,8	173	110	42	25	310	25050.0025
28	47	44	33	50	355,0	565,0	40,4	174	110	47	28	403	25050.0028
30	47	44	33	50	355,0	605,0	40,4	162	110	47	30	372	25050.0030
32	55	51	38	55	490,0	764,0	47,8	166	102	55	32	632	25050.0032
35	55	51	38	55	490,0	836,0	47,8	151	102	55	35	568	25050.0035
38	62	58	43	65	720,0	1179,0	62,1	159	111	62	38	895	25050.0038
40	62	58	43	65	720,0	1241,0	62,1	151	111	62	40	844	25050.0040

accessoires

	SW [mm]	 [g]	Artikelnr.
speciale steeksleutel			
	14	45	25050.0814
	16	72	25050.0816
	22	195	25050.0822
	27	195	25050.0827
	36	428	25050.0836
	46	610	25050.0846
	50	870	25050.0850
	55	1125	25050.0855
	65	1125	25050.0865

Toepassingsvoorbeeld

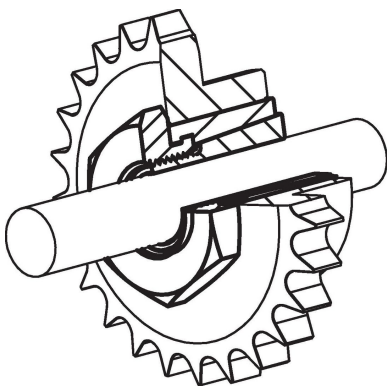

Voldoet

Selecteer voor gedetailleerde informatie over de naleving het gewenste artikelnummer.