

Sferische ringen / conische zittingen • DIN 6319

EH 23050.



Productbeschrijving

Sferische ringen / conische zittingen worden gebruikt als ringen in een schroefverbinding om niet-parallelle oppervlakken te compenseren.

Materiaal

Holle onderlegging

- Inzetgehard staal, inzetgehard, mangaan gefosfateerd
- temperstaal, veredeld, mangaan gefosfateerd

Bolle onderlegging

- Inzetgehard staal, inzetgehard, mangaan gefosfateerd

Montage

Holle onderlegging, vorm D, uitsluitend voor vlakke, gesloten ringvlakken.
Voor lange gaten alleen vorm G gebruiken.

Meer informatie

Overige producten

- Sferische ringen / conische zittingen, gelijk aan DIN 6319, RVS
- Zeskantmoeren, DIN 6330 (hoogte 1,5 d)

Tekening

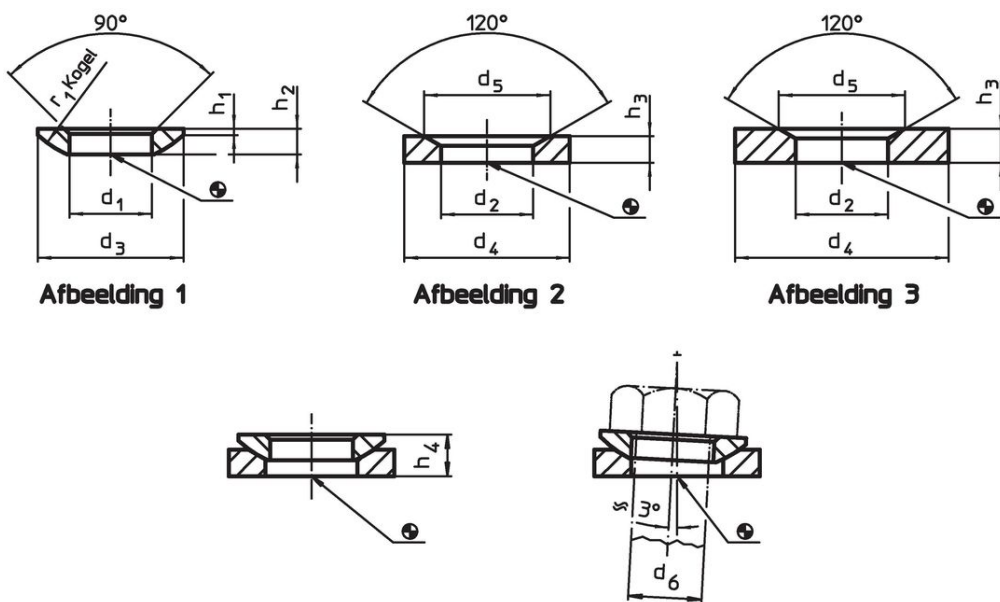

Bestelinformatie

Afmetingen											voor pen	voor	Belastbaar	Draaimoment	Artikelnr.	
d ₁	d ₂	d ₃	d ₄	d ₅	h ₁	h ₂	h ₃	h ₄		r ₁	d ₆	schroeven	heid bij	schroefverbinding		[g]
H13	H13							met bolle	met bolle		[mm]	d ₆	statische	max.		
[mm]									~	~		[mm]	[mm]	[kN]	[Nm]	
bolle onderleggingen van gehard staal, vorm C – Afbeelding 1																
6,4	–	12	–	–	0,7	2,3	–	4,2	5,4	9,0	6	M 6	9	10 ¹⁾	1,0	23050.0006
8,4	–	17	–	–	0,6	3,2	–	5,6	7,1	12,0	8	M 8	17	25 ¹⁾	2,8	23050.0008
10,5	–	21	–	–	0,8	4,0	–	6,5	7,3	15,0	10	M10	26	46 ¹⁾	5,1	23050.0010
13,0	–	24	–	–	1,1	4,6	–	8,0	9,0	17,0	12	M12	38	82 ¹⁾	8,0	23050.0012
15,0	–	28	–	–	1,4	5,0	–	8,5	9,5	22,0	14	M14	53	130 ¹⁾	12,0	23050.0014
17,0	–	30	–	–	1,3	5,3	–	9,6	10,4	22,0	16	M16	73	206 ¹⁾	13,0	23050.0016
21,0	–	36	–	–	2,0	6,3	–	11,7	12,2	27,0	20	M20	117	407 ¹⁾	23,0	23050.0020
23,0	–	40	–	–	2,5	7,6	–	13,5	–	29,5	22	M22	146	542 ¹⁾	35,0	23050.0022 ²⁾

¹⁾ Aanhaalmoment voor schroeven met standaardschroefdraad. Houd rekening met de voorspanning, wrijvingscoëfficiënt $\mu_{\text{total}} 0,14$.

²⁾ Afmetingen zijn niet in de DIN vastgelegd.

³⁾ Waarden zijn gemiddeld

d ₁ H13	d ₂ H13	d ₃	d ₄	d ₅	Afmetingen					r ₁	voor pen d ₆	voor schroeven d ₆	Belastbaar- heid bij statische belasting max.	Draaimoment schroefverbinding max.	[g]	Artikelnr.
					h ₁	h ₂	h ₃	h ₄ met bolle onderlegging vorm D ~	h ₄ met bolle onderlegging vorm G ~							
25,0	-	44	-	-	2,4	8,2	-	15,2	15,7	32,0	24	M24	168	698 ¹⁾	43,0	23050.0024
28,0	-	50	-	-	3,3	10,2	-	17,0	-	36,0	27	M27	221	1021 ¹⁾	74,0	23050.0027 ²⁾
31,0	-	56	-	-	3,6	11,2	-	19,2	19,7	41,0	30	M30	269	1355 ¹⁾	103,0	23050.0030
34,0	-	62	-	-	4,4	13,0	-	21,8	-	45,0	33	M33	326 ³⁾	1969 ³⁾ 1)	150,0	23050.0033 ²⁾
37,0	-	68	-	-	4,6	14,0	-	23,5	-	50,0	36	M36	394	2372 ¹⁾	193,0	23050.0036
40,0	-	75	-	-	5,6	16,0	-	26,8	-	54,0	39	M39	460 ³⁾	3276 ³⁾ 1)	280,0	23050.0039 ²⁾
43,0	-	78	-	-	6,5	17,0	-	29,0	-	58,0	42	M42	542	3802 ¹⁾	310,0	23050.0042
50,0	-	92	-	-	8,0	21,0	-	35,5	-	67,0	48	M48	714	5730 ¹⁾	549,0	23050.0048
54,0	-	96	-	-	9,3	22,0	-	38,3	-	72,0	52	M52	832 ³⁾	7876 ³⁾ 1)	610,0	23050.0052 ²⁾
58,0	-	103	-	-	9,8	23,0	-	39,3	-	79,0	56	M56	960 ³⁾	9793 ³⁾ 1)	760,0	23050.0056 ²⁾
62,0	-	112	-	-	11,0	25,0	-	43,6	-	86,0	60	M60	1122 ³⁾	12219 ³⁾ 1)	990,0	23050.0060 ²⁾
66,0	-	120	-	-	12,0	27,0	-	46,6	-	93,0	64	M64	1269 ³⁾	14762 ³⁾ 1)	1220,0	23050.0064 ²⁾
holle onderleggingen van gehard staal, vorm D – Afbeelding 2																
-	7,1	-	12	11,0	-	-	2,8	-	-	-	6	M 6	9	10 ¹⁾	1,3	23050.0106
-	9,6	-	17	14,5	-	-	3,5	-	-	-	8	M 8	17	25 ¹⁾	3,7	23050.0108
-	12,0	-	21	18,5	-	-	4,2	-	-	-	10	M10	26	46 ¹⁾	13,0	23050.0110
-	14,2	-	24	20,0	-	-	5,0	-	-	-	12	M12	38	82 ¹⁾	10,0	23050.0112
-	16,5	-	28	24,8	-	-	5,6	-	-	-	14	M14	53	130 ¹⁾	15,0	23050.0114
-	19,0	-	30	26,0	-	-	6,2	-	-	-	16	M16	73	206 ¹⁾	18,0	23050.0116
-	23,2	-	36	31,0	-	-	7,5	-	-	-	20	M20	117	407 ¹⁾	31,0	23050.0120
-	26,0	-	40	34,0	-	-	8,5	-	-	-	22	M22	146	542 ¹⁾	44,0	23050.0122 ²⁾
-	28,0	-	44	37,0	-	-	9,5	-	-	-	24	M24	168	698 ¹⁾	61,0	23050.0124
-	31,5	-	50	43,0	-	-	10,5	-	-	-	27	M27	221	1021 ¹⁾	87,0	23050.0127 ²⁾
-	35,0	-	56	49,0	-	-	12,0	-	-	-	30	M30	269	1355 ¹⁾	125,0	23050.0130
-	38,5	-	62	55,0	-	-	14,0	-	-	-	33	M33	326 ³⁾	1969 ³⁾ 1)	180,0	23050.0133 ²⁾
-	42,0	-	68	60,0	-	-	15,0	-	-	-	36	M36	394	2372 ¹⁾	230,0	23050.0136
-	45,0	-	75	67,0	-	-	17,0	-	-	-	39	M39	460 ³⁾	3276 ³⁾ 1)	330,0	23050.0139 ²⁾
-	49,0	-	78	70,0	-	-	18,0	-	-	-	42	M42	542	3802 ¹⁾	360,0	23050.0142
-	56,0	-	92	82,0	-	-	22,0	-	-	-	48	M48	714	5730 ¹⁾	640,0	23050.0148
-	60,0	-	96	85,0	-	-	24,0	-	-	-	52	M52	832 ³⁾	7876 ³⁾ 1)	740,0	23050.0152 ²⁾
-	65,0	-	103	93,0	-	-	25,0	-	-	-	56	M56	960 ³⁾	9793 ³⁾ 1)	900,0	23050.0156 ²⁾
-	70,0	-	112	102,0	-	-	28,0	-	-	-	60	M60	1122 ³⁾	12219 ³⁾ 1)	1160,0	23050.0160 ²⁾
-	75,0	-	120	110,0	-	-	30,0	-	-	-	64	M64	1269 ³⁾	14762 ³⁾ 1)	1430,0	23050.0164 ²⁾
holle onderleggingen van temperstaal, vorm G – Afbeelding 3																
-	7,1	-	17	11,0	-	-	4,0	-	-	-	6	M 6	9	10 ¹⁾	5,6	23050.0206
-	9,6	-	24	14,5	-	-	5,0	-	-	-	8	M 8	17	25 ¹⁾	14,0	23050.0208
-	12,0	-	30	18,5	-	-	5,0	-	-	-	10	M10	26	46 ¹⁾	22,0	23050.0210
-	14,2	-	36	20,0	-	-	6,0	-	-	-	12	M12	38	82 ¹⁾	39,0	23050.0212
-	16,5	-	40	24,8	-	-	6,0	-	-	-	14	M14	53	130 ¹⁾	47,0	23050.0214
-	19,0	-	44	26,0	-	-	7,0	-	-	-	16	M16	73	206 ¹⁾	65,0	23050.0216
-	23,2	-	50	31,0	-	-	8,0	-	-	-	20	M20	117	407 ¹⁾	93,0	23050.0220
-	28,0	-	60	37,0	-	-	10,0	-	-	-	24	M24	168	698 ¹⁾	165,0	23050.0224
-	35,0	-	68	49,0	-	-	12,0	-	-	-	30	M30	269	1355 ¹⁾	235,0	23050.0230

¹⁾ Aanhaalmoment voor schroeven met standaardschroefdraad. Houd rekening met de voorspanning, wrijvingscoëfficiënt μ_{total} 0,14.

²⁾ Afmetingen zijn niet in de DIN vastgelegd.

³⁾ Waarden zijn gemiddeld

Toepassingsvoorbeeld

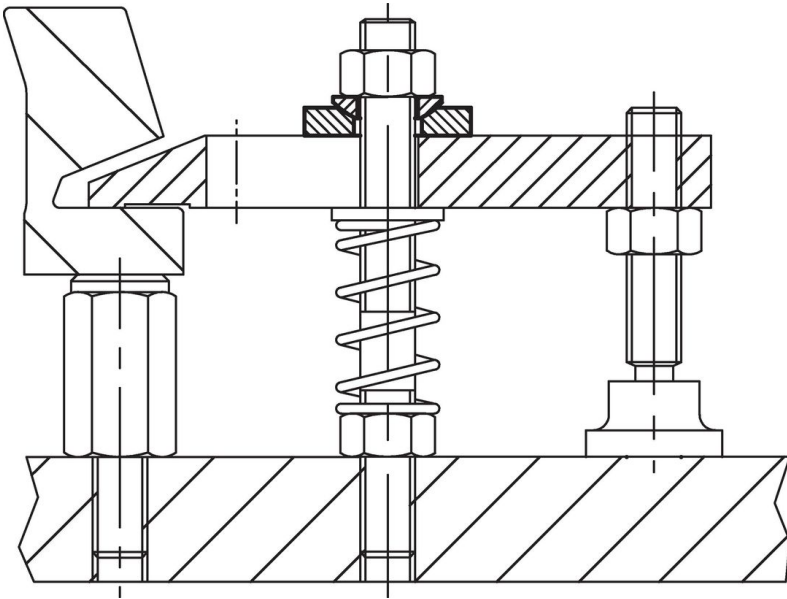

Voldoet

Selecteer voor gedetailleerde informatie over de naleving het gewenste artikelnummer.