

편심 클램프 · with slot tenon

EH 23270.

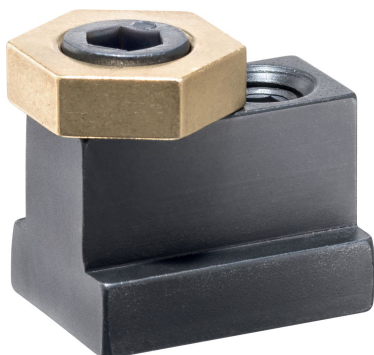

제품 설명

The eccentric clamping clamps can be used for quick and easy workpiece clamping directly on the machine table or a base plate with T-slots.

These eccentric clamping clamps with slot tenon are locked in a T-slot, for example on the machine table, with a thrust screw. Clamping takes place via the clamping screw with eccentric head. The brass basic element ensures gentle and secure clamping.

The eccentric clamping clamps with slot tenon have the following characteristics:

- Brass base element for material-friendly clamping
- Quick clamping thanks to clamping screw with eccentric head
- High clamping force is achieved
- Low design enables the machining of flat workpieces
- The compact dimensions enable space-saving multiple clamping

재질

편심 스크류

- 스틸

나사 핀

- 스틸, 흑색처리

몸체

- 동

Slot tenon

- 스틸, 경화처리, 흑색처리

더 많은 정보

참조

The head of the eccentric screw can slightly protrude from the body (h_1).

그림

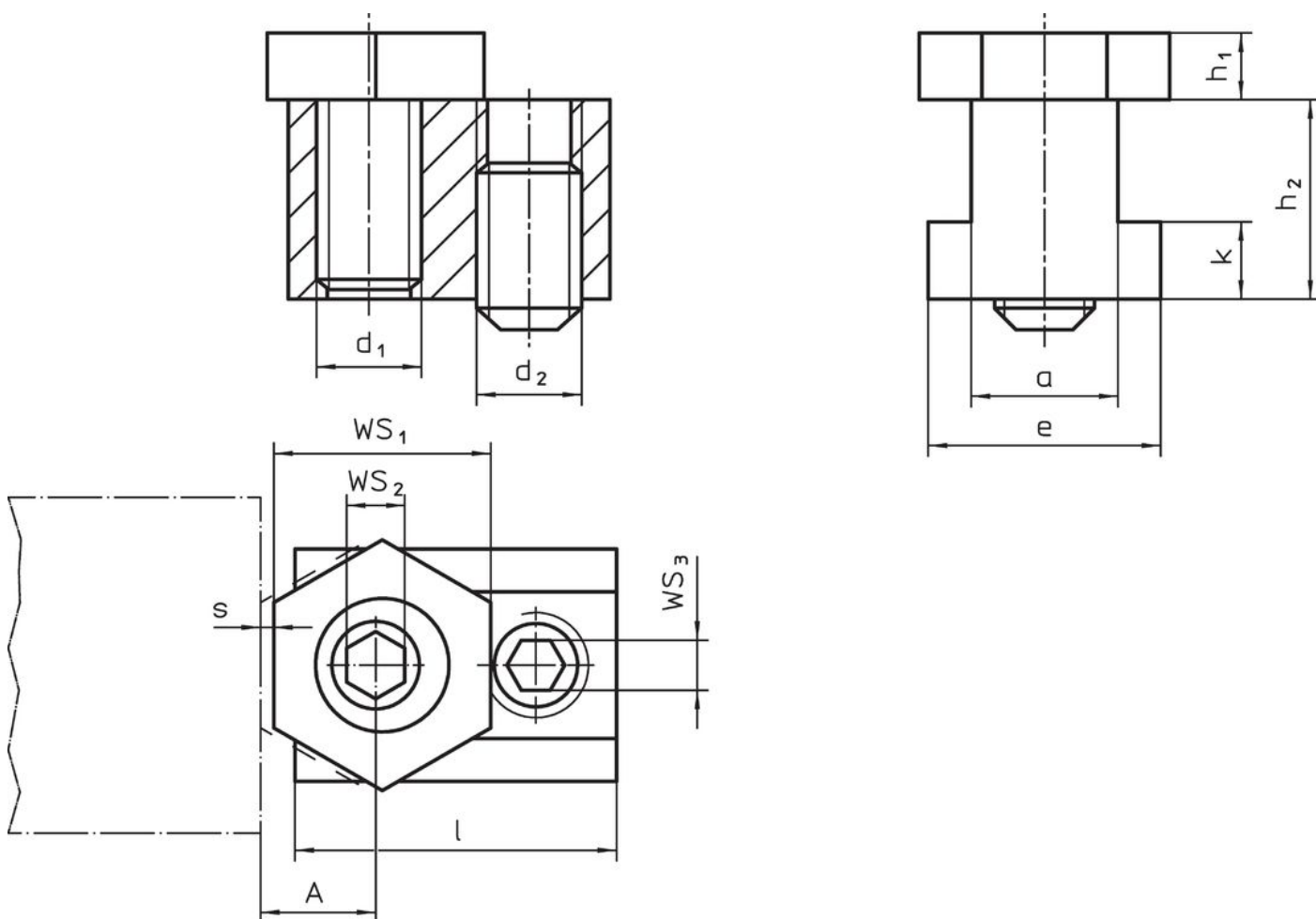

주문 정보

T-슬롯 사이즈 [mm]	d ₁	a	e	치수					A	WS ₁	WS		클램핑력 최대	조임 토크 WS ₂ 최대	조임 토크 WS ₃ 최대	[g]	제품 번호.
				h ₁	h ₂	k	s	l			WS ₂	WS ₃					
				[mm]					[mm]	[mm]		[kN]	[Nm]	[Nm]	[g]		
10	M 6	9,8	14,3	4,8	14,3	4,4	1,0	23,2	7,8	16,0	4	3	3,4	10	8	35	23270.0410
14	M10	13,7	22,1	6,4	22,1	8,1	1,3	30,5	10,2	20,6	7	5	7,0	26	35	100	23270.0414
18	M12	17,7	28,5	9,5	28,5	10,5	2,5	34,7	12,7	25,4	8	6	9,0	75	55	190	23270.0418

적용 예

