

偏心クランプ・with slot tenon

EH 23270.

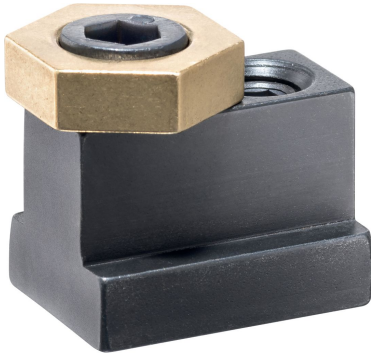

製品説明

The eccentric clamping clamps can be used for quick and easy workpiece clamping directly on the machine table or a base plate with T-slots.

These eccentric clamping clamps with slot tenon are locked in a T-slot, for example on the machine table, with a thrust screw. Clamping takes place via the clamping screw with eccentric head. The brass basic element ensures gentle and secure clamping.

The eccentric clamping clamps with slot tenon have the following characteristics:

- Brass base element for material-friendly clamping
- Quick clamping thanks to clamping screw with eccentric head
- High clamping force is achieved
- Low design enables the machining of flat workpieces
- The compact dimensions enable space-saving multiple clamping

材質

偏心ねじ

- 鋼

グリップスクリュー

- スティール、黒染

本体

- 黄銅

Slot tenon

- スティール、焼入れ、黒染

寸法図

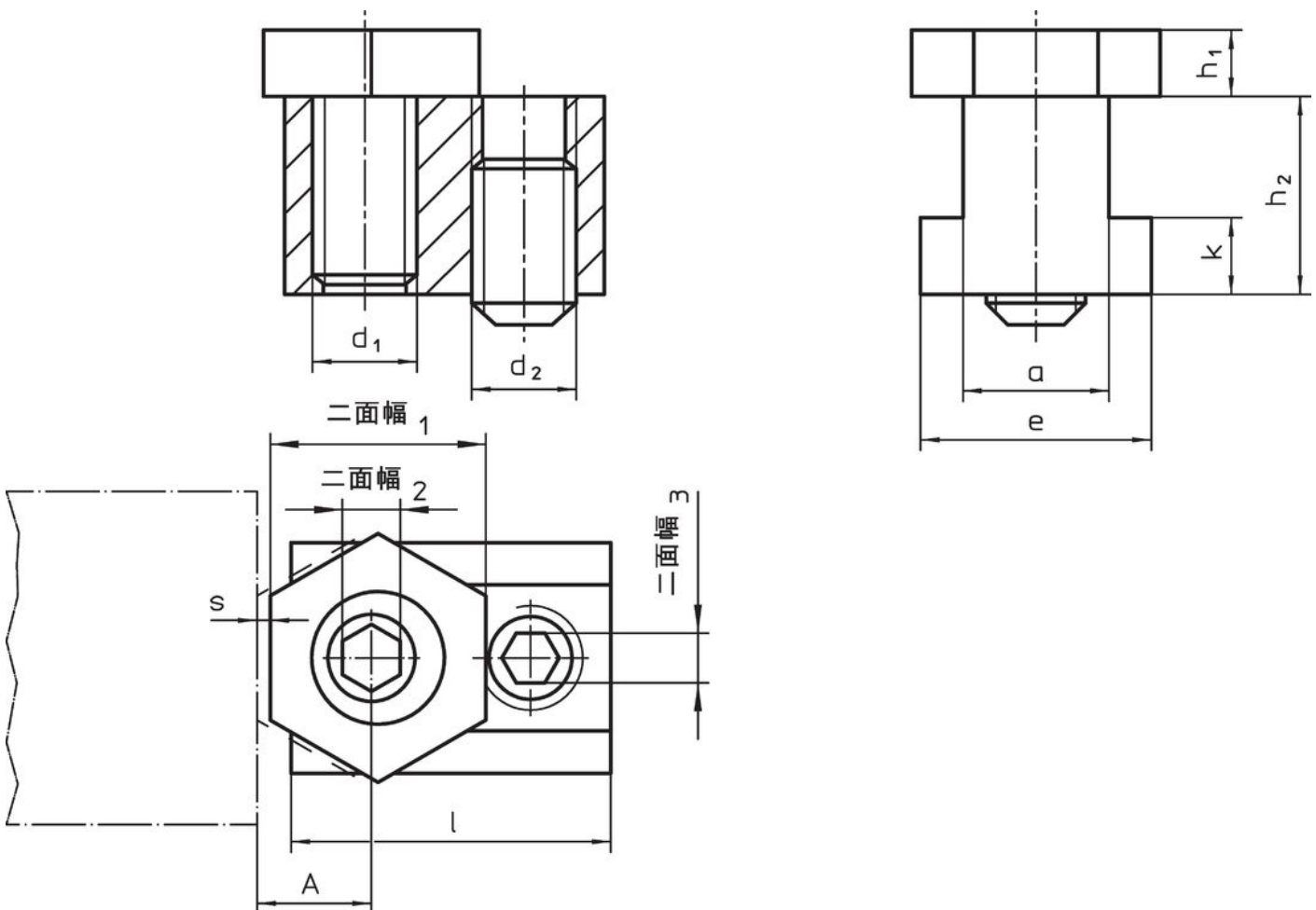

発注情報

| T溝幅 | d ₁ | a | e | 寸法 | | | | | A | 二面幅 | | | 締付力 max. | 締付トルク 二面幅 ₂ max. | 締付トルク 二面幅 ₃ max. | 重量 | 製品番号 |
|------|----------------|------|------|----------------|----------------|------|-----|------|------|------------------|------------------|------------------|----------|-----------------------------|-----------------------------|-----|------------|
| | | | | h ₁ | h ₂ | k | s | l | | 二面幅 ₁ | 二面幅 ₂ | 二面幅 ₃ | | | | | |
| [mm] | | | | [mm] | | | | | [mm] | [mm] | | | [kN] | [Nm] | [Nm] | [g] | |
| 10 | M 6 | 9,8 | 14,3 | 4,8 | 14,3 | 4,4 | 1,0 | 23,2 | 7,8 | 16,0 | 4 | 3 | 3,4 | 10 | 8 | 35 | 23270.0410 |
| 14 | M10 | 13,7 | 22,1 | 6,4 | 22,1 | 8,1 | 1,3 | 30,5 | 10,2 | 20,6 | 7 | 5 | 7,0 | 26 | 35 | 100 | 23270.0414 |
| 18 | M12 | 17,7 | 28,5 | 9,5 | 28,5 | 10,5 | 2,5 | 34,7 | 12,7 | 25,4 | 8 | 6 | 9,0 | 75 | 55 | 190 | 23270.0418 |

応用例

