

ボアクランプ・マンドレル・円筒形

23340.0510



製品説明

The centering clamping mandrels, cylindrical are ideal for use in fixture construction. They enable workpieces to be clamped with a hole on their inside diameter and therefore without interfering clamping edges. The centering clamping mandrels can be mounted on grid and fixture plates, for example, by pressing them into bores or screwing them into threads.

They enable exact positioning, offer precise repeat accuracy and achieve high holding forces when clamping parts with holes. The centering clamping mandrels offer the possibility of fixing complex workpieces without external clamping elements to enable these components to be machined on 5 sides.

The centering clamping mandrels, cylindrical have the following characteristics:

- Clamping stroke max. 0.7 mm
- Two versions - for press-in or screw-in
- Made of stainless steel or free-cutting steel
- Clamping body can be machined very easily (for adaptation to bore diameter)

材質

本体

- 快削鋼

クランプネジ

- 鋼

組立

The centering clamping mandrel can be adjusted to the respective diameter by turning or milling.

Picture 1 - Mounting in bore hole or socket.

Thread for clamping screw required.

Picture 2 - Mounting in thread.

Clamping screw for the mounting.

Remove from body.

Screw-in centering clamping elements and tighten using the wrench size (WS₂).

取り扱い

It is operated using the conical clamping screw (WS1). This expands the body by up to 0.7 mm.

寸法図

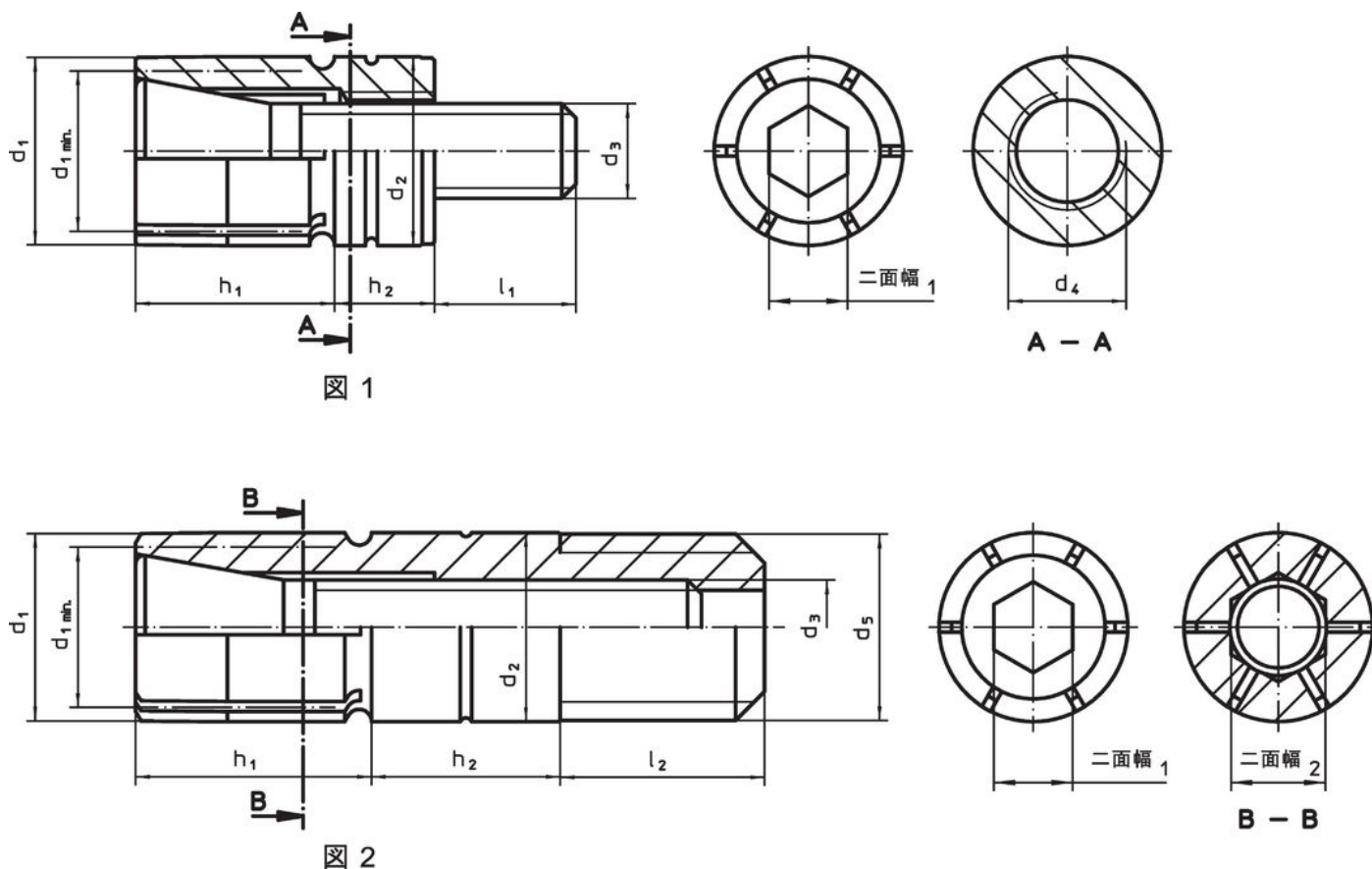

発注情報

d_1	d_1 min.	d_2 -0,025	d_3	寸法 d_4 h_1 h_2 l_1 [mm]				二面幅 二面幅 ₁ [mm]	口金数	締付力 max. [kN]	締付トルク max. [Nm]	取付穴 [mm]	 [g]	製品番号
press-fit – 図 1, 快削鋼														
10	7,5	10	M4	M5	12,7	6,35	8,4	4	4	4,2	5	10	12	23340.0510

応用例

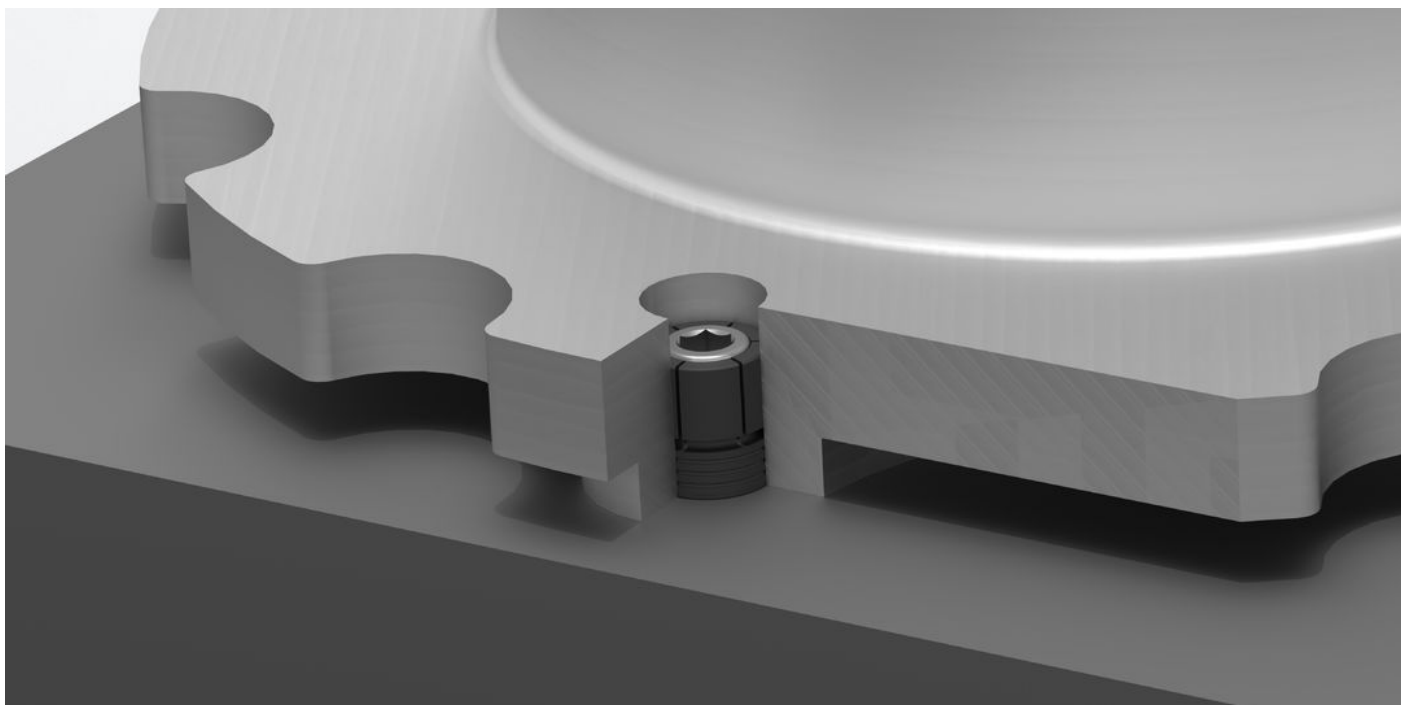

法令(コンプライアンス)

RoHS準拠

2011/65/EUと2015/863指令に適合しています

SVHC材の含有は無し

0.1%(質量%濃度)以上の高懸念物質(SVHC)は使用していません-2024年1月23日SVHCリスト対象.

プロポジション65の物質は含有していません

プロポジション65の指定物質は含まれていません

<https://www.P65Warnings.ca.gov/>

紛争物質は使用していません

本製品は、コンゴ民主共和国や隣国地域から産出されるチタン、錫、金、タングステンなどのいかなる「紛争鉱物」に由来する物質を使っていません。