

Cerniere • elongated on both sides

25165.1075



Descrizione prodotto

The different versions cover many applications that require a low load.

These metal hinges are characterised by their simple design and the different versions:

- without bores
- with bores
- with bores for countersunk screws

The version without bores can be assembled by welding or by inserting a specific drilling pattern.

Materiale

Corpo

- Acciaio, zincato e passivato

Asse

- Acciaio inox 1.4301

Disegno

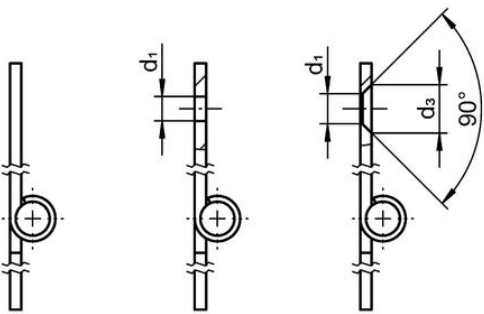
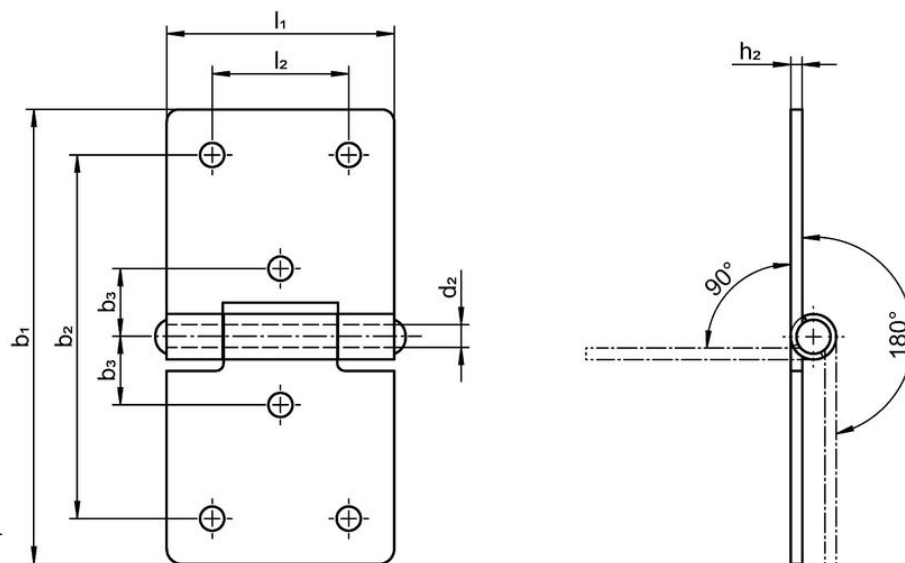

picture 1

picture 2

picture 3

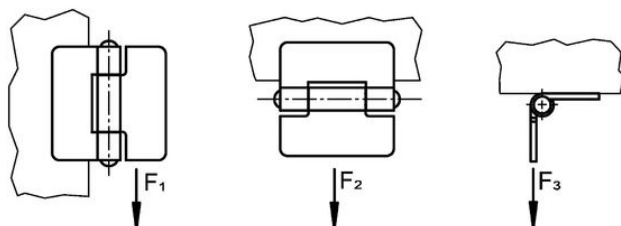

Caratteristiche

Dimensioni										Forza di ritegno				Codice
b ₁	l ₁	b ₂	b ₃	d ₁	d ₂	h ₁ ~	h ₂	l ₂	F ₁ ~	F ₂ ~	F ₃ ~	[g]		
[mm]										[N]				
with bores – Fig. 2, Acciaio														
80	40	65	12,5	4,2	4	8	2	25	1200	1000	1000	58	25165.1075	

Conformità

Conforme alla normativa RoHS

Conforme alla Direttiva 2011/65/UE e alla Direttiva 2015/863.

Non contiene sostanze SVHC

Nessuna sostanza SVHC con più dello 0,1% p/p contenuto - elenco SVHC [REACH] aggiornato al 23.01.2024.

Non contiene sostanze della Proposition 65

Nessuna sostanza contemplata nella Proposition 65

<https://www.P65Warnings.ca.gov/>

Privo di minerali di conflitto

Questo prodotto non contiene sostanze designate come "minerali da conflitto" come tantalio, stagno, oro o tungsteno della Repubblica Democratica del Congo o dei paesi limitrofi.