

## Cerniere • elongated on both sides

25165.0275



### Descrizione prodotto

The different versions cover many applications that require a low load.

These metal hinges are characterised by their simple design and the different versions:

- without bores
- with bores
- with bores for countersunk screws

The version without bores can be assembled by welding or by inserting a specific drilling pattern.

### Materiale

#### Corpo

- Acciaio inox 1.4301

#### Asse

- Acciaio inox 1.4301

### Disegno

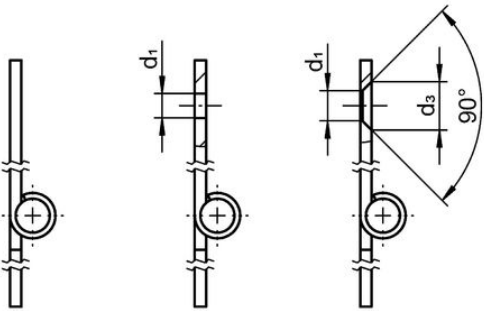
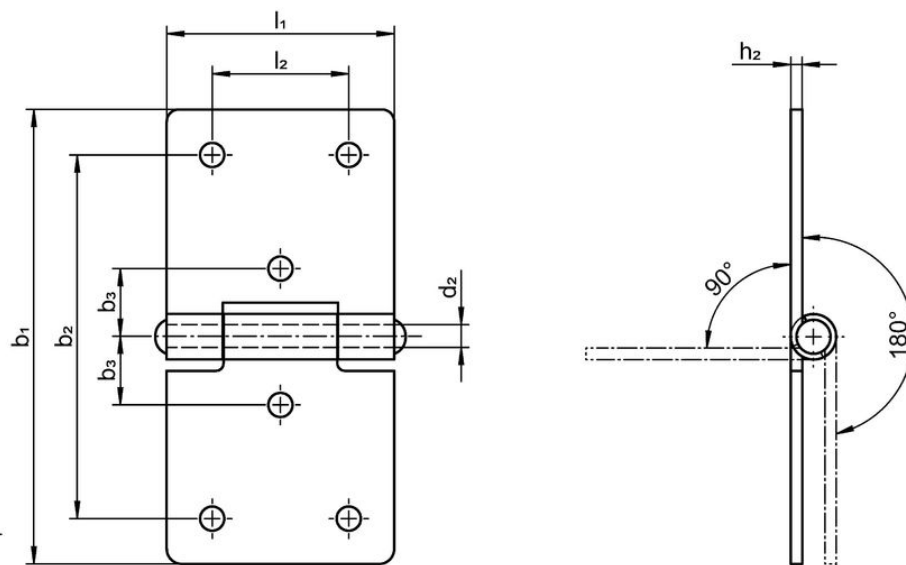

picture 1

picture 2

picture 3

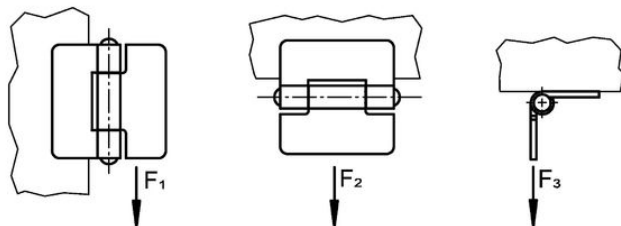

## Caratteristiche

Dimensioni										Forza di ritegno				Codice
b <sub>1</sub>	l <sub>1</sub>	b <sub>2</sub>	b <sub>3</sub>	d <sub>1</sub>	d <sub>2</sub>	d <sub>3</sub>	h <sub>1</sub> ~	h <sub>2</sub>	l <sub>2</sub>	F <sub>1</sub> ~	F <sub>2</sub> ~ [N]	F <sub>3</sub> ~		
with bores for countersunk screws – Fig. 3, acciaio inox														
80	40	65	12,5	5	4	8,3	8	2	25	1200	1000	1000	58	<a href="#">25165.0275</a>

## Conformità

### Conforme alla normativa RoHS

Conforme alla Direttiva 2011/65/UE e alla Direttiva 2015/863.

### Non contiene sostanze SVHC

Nessuna sostanza SVHC con più dello 0,1% p/p contenuto - elenco SVHC [REACH] aggiornato al 23.01.2024.

### Non contiene sostanze della Proposition 65

Nessuna sostanza contemplata nella Proposition 65

<https://www.P65Warnings.ca.gov/>

### Privo di minerali di conflitto

Questo prodotto non contiene sostanze designate come "minerali da conflitto" come tantalio, stagno, oro o tungsteno della Repubblica Democratica del Congo o dei paesi limitrofi.