

Spring Plungers • with pin and internal hexagon - INCH EH 2B030.



Product Description

To be used for positioning, indexing, locking, latching as well as for other similar pressure applications.
Spring plungers can be used for locating or for applying pressure, as a detent or for ejection.

Material

Pin

- Free cutting steel, hardened, blackened
- Stainless Steel 1.4305 (ASTM-A-582), nitrided

Body

- Free cutting steel, blackened
- Stainless steel 1.4305 (ASTM-A-582)

Spring

- Stainless steel

Characteristic

Standard spring load: no marking
Heavy spring load: marked with two lines

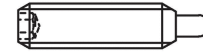

Standard spring load



Heavy spring load

More information

Notes

Customized design on request.
Spring plungers are specially tested for spring range and forces.

- This product is manufactured in INCH dimensions.

References

A conversion table can be found in the technical data following these product information pages.
Thread lock: polyamide spot coating (for details please refer to the technical appendix).

Further products

- Spring Plungers, with pin and internal hexagon

Drawing

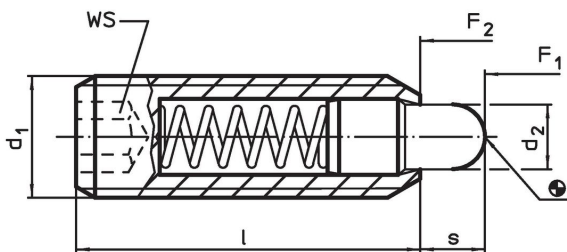

Order information

d ₁	Dimensions		d ₂	l	WS	Stroke s	Spring load ¹⁾		Temperature		Weight [oz]	Art. No.	
	[in]	Thread					[in]	[in]	F ₁ ~ [lb]	F ₂ ~ [lb]			min. [°F]
free cutting steel, standard spring load, Without thread lock													
#6-32		0.138	2A-UNC	0.046	17/32	1/16	0.063	0.5	1.5	-22	482	0.025	2B030.0033
#8-32		0.164	2A-UNC	0.070	5/8	5/64	0.094	0.8	2.3	-22	482	0.042	2B030.0036
#10-32		0.190	2A-UNF	0.093	3/4	3/32	0.125	1.4	2.7	-22	482	0.057	2B030.0040
1/4-20	1/4	0.250	2A-UNC	0.119	1	1/8	0.188	1.0	4.0	-22	482	0.121	2B030.0042
1/4-28	1/4	0.250	2A-UNF	0.119	1	1/8	0.188	1.0	4.0	-22	482	0.134	2B030.0044
5/16-18	5/16	0.313	2A-UNC	0.135	1	5/32	0.188	1.5	4.5	-22	482	0.205	2B030.0046
3/8-16	3/8	0.375	2A-UNC	0.186	1 1/8	3/16	0.188	2.7	7.2	-22	482	0.331	2B030.0048
1/2-13	1/2	0.500	2A-UNC	0.248	1 1/4	1/4	0.250	2.7	9.3	-22	482	0.649	2B030.0050
5/8-11	5/8	0.625	2A-UNC	0.310	1 1/2	5/16	0.313	3.5	10.6	-22	482	1.242	2B030.0052
3/4-10	3/4	0.750	2A-UNC	0.374	1 3/4	3/8	0.313	5.5	14.5	-22	482	2.172	2B030.0053
1-8	1	0.125	2A-UNC	0.499	2 13/32	3/8	0.500	4.0	31.0	-22	482	5.443	2B030.0054

¹⁾ statistical average value

	Dimensions					WS [in]	Stroke s [in]	Spring load ¹⁾		min. max.		[oz]	Art. No.
	d ₁	Thread	d ₂	l	F ₁ ~ [lb]			F ₂ ~ [lb]	min.	max.			
											[in]		
free cutting steel, standard spring load, With thread lock													
#6-32		0.138	2A-UNC	0.046	17/32	1/16	0.063	0.5	1.5	-22	194	0.028	2B030.0233
#8-32		0.164	2A-UNC	0.070	5/8	5/64	0.094	0.8	2.3	-22	194	0.033	2B030.0236
#10-32		0.190	2A-UNF	0.093	3/4	3/32	0.125	1.4	2.7	-22	194	0.057	2B030.0240
1/4-20	1/4	0.250	2A-UNC	0.119	1	1/8	0.188	1.0	4.0	-22	194	0.120	2B030.0242
1/4-28	1/4	0.250	2A-UNF	0.119	1	1/8	0.188	1.0	4.0	-22	194	0.145	2B030.0244
5/16-18	5/16	0.313	2A-UNC	0.135	1	5/32	0.188	1.5	4.5	-22	194	0.196	2B030.0246
3/8-16	3/8	0.375	2A-UNC	0.186	1 1/8	3/16	0.188	2.7	7.2	-22	194	0.331	2B030.0248
1/2-13	1/2	0.500	2A-UNC	0.248	1 1/4	1/4	0.250	2.7	9.3	-22	194	0.649	2B030.0250
5/8-11	5/8	0.625	2A-UNC	0.310	1 1/2	5/16	0.313	3.5	10.6	-22	194	1.249	2B030.0252
3/4-10	3/4	0.750	2A-UNC	0.374	1 3/4	3/8	0.313	5.5	14.5	-22	194	2.174	2B030.0253
1-8	1	0.125	2A-UNC	0.499	2 13/32	3/8	0.500	4.0	31.0	-22	194	7.668	2B030.0254
free cutting steel, heavy spring load, Without thread lock													
#6-32		0.138	2A-UNC	0.046	17/32	1/16	0.063	1.5	3.4	-22	482	0.019	2B030.0063
#8-32		0.164	2A-UNC	0.070	5/8	5/64	0.094	2.6	6.6	-22	482	0.033	2B030.0066
#10-32		0.190	2A-UNF	0.093	3/4	3/32	0.125	3.2	9.0	-22	482	0.058	2B030.0070
1/4-20	1/4	0.250	2A-UNC	0.119	1	1/8	0.188	3.1	10.1	-22	482	0.122	2B030.0072
1/4-28	1/4	0.250	2A-UNF	0.119	1	1/8	0.188	3.1	10.1	-22	482	0.145	2B030.0074
5/16-18	5/16	0.313	2A-UNC	0.135	1	5/32	0.188	3.0	15.0	-22	482	0.208	2B030.0076
3/8-16	3/8	0.375	2A-UNC	0.186	1 1/8	3/16	0.188	5.5	12.7	-22	482	0.335	2B030.0078
1/2-13	1/2	0.500	2A-UNC	0.248	1 1/4	1/4	0.250	6.6	16.0	-22	482	0.649	2B030.0080
5/8-11	5/8	0.625	2A-UNC	0.310	1 1/2	5/16	0.313	10.5	22.2	-22	482	1.245	2B030.0082
3/4-10	3/4	0.750	2A-UNC	0.374	1 3/4	3/8	0.313	6.7	33.0	-22	482	2.174	2B030.0083
1-8	1	0.125	2A-UNC	0.499	2 13/32	3/8	0.500	16.0	60.0	-22	482	5.538	2B030.0084
free cutting steel, heavy spring load, With thread lock													
#6-32		0.138	2A-UNC	0.046	17/32	1/16	0.063	1.5	3.4	-22	194	0.019	2B030.0263
#8-32		0.164	2A-UNC	0.070	5/8	5/64	0.094	2.6	6.6	-22	194	0.033	2B030.0266
#10-32		0.190	2A-UNF	0.093	3/4	3/32	0.125	3.2	9.0	-22	194	0.067	2B030.0270
1/4-20	1/4	0.250	2A-UNC	0.119	1	1/8	0.188	3.1	10.1	-22	194	0.099	2B030.0272
1/4-28	1/4	0.250	2A-UNF	0.119	1	1/8	0.188	3.1	10.1	-22	194	0.145	2B030.0274
5/16-18	5/16	0.313	2A-UNC	0.135	1	5/32	0.188	3.0	15.0	-22	194	0.199	2B030.0276
3/8-16	3/8	0.375	2A-UNC	0.186	1 1/8	3/16	0.188	5.5	12.7	-22	194	0.328	2B030.0278
1/2-13	1/2	0.500	2A-UNC	0.248	1 1/4	1/4	0.250	6.6	16.0	-22	194	0.650	2B030.0280
5/8-11	5/8	0.625	2A-UNC	0.310	1 1/2	5/16	0.313	10.5	22.2	-22	194	1.245	2B030.0282
3/4-10	3/4	0.750	2A-UNC	0.374	1 3/4	3/8	0.313	6.7	33.0	-22	194	2.176	2B030.0283
1-8	1	0.125	2A-UNC	0.499	2 13/32	3/8	0.500	16.0	60.0	-22	194	5.496	2B030.0284
stainless steel, standard spring load, Without thread lock													
#6-32		0.138	2A-UNC	0.046	17/32	1/16	0.063	0.5	1.5	-22	482	0.018	2B030.0133
#8-32		0.164	2A-UNC	0.070	5/8	5/64	0.094	0.8	2.3	-22	482	0.033	2B030.0136
#10-32		0.190	2A-UNF	0.093	3/4	3/32	0.125	1.4	2.7	-22	482	0.057	2B030.0140
1/4-20	1/4	0.250	2A-UNC	0.119	1	1/8	0.188	1.0	4.0	-22	482	0.120	2B030.0142
1/4-28	1/4	0.250	2A-UNF	0.119	1	1/8	0.188	1.0	4.0	-22	482	0.141	2B030.0144
5/16-18	5/16	0.313	2A-UNC	0.135	1	5/32	0.188	1.5	4.5	-22	482	0.208	2B030.0146
3/8-16	3/8	0.375	2A-UNC	0.186	1 1/8	3/16	0.188	2.7	7.2	-22	482	0.330	2B030.0148
1/2-13	1/2	0.500	2A-UNC	0.248	1 1/4	1/4	0.250	2.7	9.3	-22	482	0.653	2B030.0150
5/8-11	5/8	0.625	2A-UNC	0.310	1 1/2	5/16	0.313	3.5	10.6	-22	482	1.249	2B030.0152
3/4-10	3/4	0.750	2A-UNC	0.374	1 3/4	3/8	0.313	5.5	14.5	-22	482	2.180	2B030.0153
1-8	1	0.125	2A-UNC	0.499	2 13/32	3/8	0.500	4.0	31.0	-22	482	5.475	2B030.0154
stainless steel, standard spring load, With thread lock													
#6-32		0.138	2A-UNC	0.046	17/32	1/16	0.063	0.5	1.5	-22	194	0.019	2B030.0333
#8-32		0.164	2A-UNC	0.070	5/8	5/64	0.094	0.8	2.3	-22	194	0.039	2B030.0336
#10-32		0.190	2A-UNF	0.093	3/4	3/32	0.125	1.4	2.7	-22	194	0.063	2B030.0340
1/4-20	1/4	0.250	2A-UNC	0.119	1	1/8	0.188	1.0	4.0	-22	194	0.121	2B030.0342
1/4-28	1/4	0.250	2A-UNF	0.119	1	1/8	0.188	1.0	4.0	-22	194	0.141	2B030.0344
5/16-18	5/16	0.313	2A-UNC	0.135	1	5/32	0.188	1.5	4.5	-22	194	0.208	2B030.0346
3/8-16	3/8	0.375	2A-UNC	0.186	1 1/8	3/16	0.188	2.7	7.2	-22	194	0.339	2B030.0348

¹⁾ statistical average value

d ₁		Dimensions				WS	Stroke s	Spring load ¹⁾		min. max.		oz	Art. No.
		[in]	Thread	d ₂	l			F ₁	F ₂	[°F]			
		[in]			[in]	[in]	[in]	[lb]			[°F]	[oz]	
1/2-13	1/2	0.500	2A-UNC	0.248	1 1/4	1/4	0.250	2.7	9.3	-22	194	0.653	2B030.0350
5/8-11	5/8	0.625	2A-UNC	0.310	1 1/2	5/16	0.313	3.5	10.6	-22	194	1.249	2B030.0352
3/4-10	3/4	0.750	2A-UNC	0.374	1 3/4	3/8	0.313	5.5	14.5	-22	194	2.187	2B030.0353
1-8	1	0.125	2A-UNC	0.499	2 13/32	3/8	0.500	4.0	31.0	-22	194	5.464	2B030.0354
stainless steel, heavy spring load, Without thread lock													
#6-32		0.138	2A-UNC	0.046	17/32	1/16	0.063	1.5	3.4	-22	482	0.019	2B030.0163
#8-32		0.164	2A-UNC	0.070	5/8	5/64	0.094	2.6	6.6	-22	482	0.034	2B030.0166
#10-32		0.190	2A-UNF	0.093	3/4	3/32	0.125	3.2	9.0	-22	482	0.063	2B030.0170
1/4-20	1/4	0.250	2A-UNC	0.119	1	1/8	0.188	3.1	10.1	-22	482	0.122	2B030.0172
1/4-28	1/4	0.250	2A-UNF	0.119	1	1/8	0.188	3.1	10.1	-22	482	0.145	2B030.0174
5/16-18	5/16	0.313	2A-UNC	0.135	1	5/32	0.188	3.0	15.0	-22	482	0.168	2B030.0176
3/8-16	3/8	0.375	2A-UNC	0.186	1 1/8	3/16	0.188	5.5	12.7	-22	482	0.339	2B030.0178
1/2-13	1/2	0.500	2A-UNC	0.248	1 1/4	1/4	0.250	6.6	16.0	-22	482	0.653	2B030.0180
5/8-11	5/8	0.625	2A-UNC	0.310	1 1/2	5/16	0.313	10.5	22.2	-22	482	1.252	2B030.0182
3/4-10	3/4	0.750	2A-UNC	0.374	1 3/4	3/8	0.313	6.7	33.0	-22	482	2.188	2B030.0183
1-8	1	0.125	2A-UNC	0.499	2 13/32	3/8	0.500	16.0	60.0	-22	482	5.524	2B030.0184
stainless steel, heavy spring load, With thread lock													
#6-32		0.138	2A-UNC	0.046	17/32	1/16	0.063	1.5	3.4	-22	194	0.019	2B030.0363
#8-32		0.164	2A-UNC	0.070	5/8	5/64	0.094	2.6	6.6	-22	194	0.034	2B030.0366
#10-32		0.190	2A-UNF	0.093	3/4	3/32	0.125	3.2	9.0	-22	194	0.057	2B030.0370
1/4-20	1/4	0.250	2A-UNC	0.119	1	1/8	0.188	3.1	10.1	-22	194	0.131	2B030.0372
1/4-28	1/4	0.250	2A-UNF	0.119	1	1/8	0.188	3.1	10.1	-22	194	0.145	2B030.0374
5/16-18	5/16	0.313	2A-UNC	0.135	1	5/32	0.188	3.0	15.0	-22	194	0.212	2B030.0376
3/8-16	3/8	0.375	2A-UNC	0.186	1 1/8	3/16	0.188	5.5	12.7	-22	194	0.339	2B030.0378
1/2-13	1/2	0.500	2A-UNC	0.248	1 1/4	1/4	0.250	6.6	16.0	-22	194	0.638	2B030.0380
5/8-11	5/8	0.625	2A-UNC	0.310	1 1/2	5/16	0.313	10.5	22.2	-22	194	1.256	2B030.0382
3/4-10	3/4	0.750	2A-UNC	0.374	1 3/4	3/8	0.313	6.7	33.0	-22	194	2.191	2B030.0383
1-8	1	0.125	2A-UNC	0.499	2 13/32	3/8	0.500	16.0	60.0	-22	194	5.524	2B030.0384

¹⁾ statistical average value

Application example

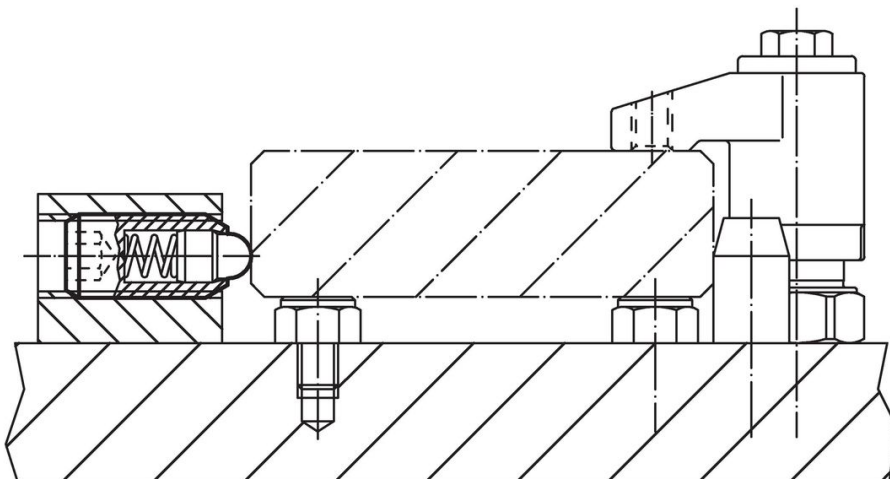

Compliance

For detailed compliance information please select the desired article number.