

Handwheels • similar to DIN 950, stainless steel

EH 24591.



Product Description

Hub machined; rim turned and mirror-finished on all sides, non-machined surfaces cleanly blasted.

Material

Handwheel

- Stainless steel A4

Machine handle

- Stainless steel A4

Assembly

Shaft-end washers EH 22270. for axial fastening.

More information

Further products

- Shaft-End Washers

Drawing

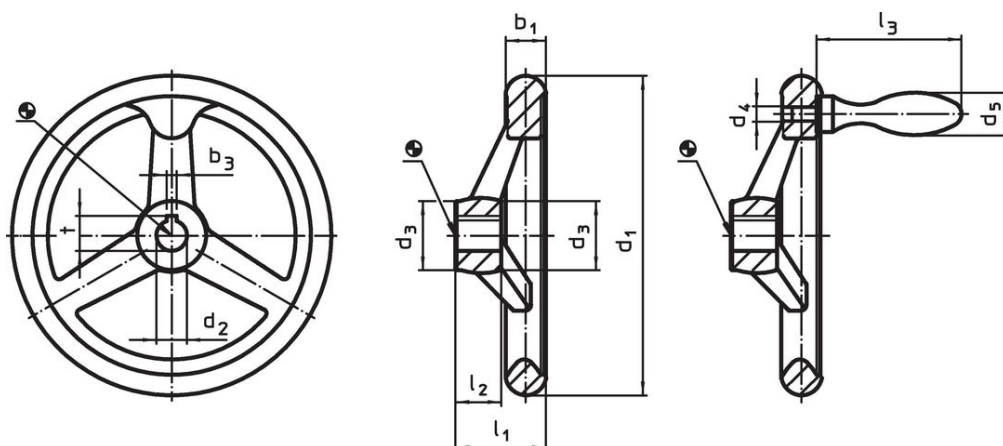



picture 1

picture 2

The orientation of the hub keyway may be different than shown in the drawing.

Order information

Dimensions								Hub keyway, DIN 6885 sheet 1		Number of spokes	Corresponding machine handle DIN 39	 [g]	Art. No.
d ₁	d ₂ H9	d ₃	d ₄	d ₅	l ₁	l ₂	l ₃	b ₃	t				
[mm]								[mm]					
without hub keyway, without handle, form B-F/A (formerly: A 4) – picture 1													
100	10	25.5	–	–	33.0	17	–	–	–	3	–	431	24591.0005
125	12	27.0	–	–	35.5	18	–	–	–	3	–	633	24591.0010
140	14	29.0	–	–	38.5	19	–	–	–	3	–	851	24591.0015
160	14	31.0	–	–	39.5	20	–	–	–	3	–	1112	24591.0020
200	18	37.0	–	–	44.5	24	–	–	–	3	–	1877	24591.0030
with hub keyway, without handle, form N-F/A (formerly: A 3) – picture 1													
100	10	25.5	–	–	33.0	17	–	3	11.4	3	–	434	24591.0105
125	12	27.0	–	–	35.5	18	–	4	13.8	3	–	659	24591.0110
140	14	29.0	–	–	38.5	19	–	5	16.3	3	–	854	24591.0115
160	14	31.0	–	–	39.5	20	–	5	16.3	3	–	1115	24591.0120
200	18	37.0	–	–	44.5	24	–	6	20.8	3	–	1882	24591.0130
without hub keyway, with machine handle EH 24450., assembled, form B-F/G (formerly: F 4) – picture 2													
100	10	25.5	M 6	16	33.0	17	50	–	–	3	16	472	24591.0405
125	12	27.0	M 8	20	35.5	18	64	–	–	3	20	748	24591.0410
140	14	29.0	M 8	20	38.5	19	64	–	–	3	20	939	24591.0415
160	14	31.0	M10	25	39.5	20	80	–	–	3	25	1273	24591.0420
200	18	37.0	M10	25	44.5	24	80	–	–	3	25	2000	24591.0430

Dimensions								Hub keyway, DIN 6885 sheet 1		Number of spokes	Corresponding machine handle DIN 39		Art. No.
d ₁	d ₂ H9	d ₃	d ₄	d ₅	l ₁	l ₂	l ₃ ~	b ₃	t				
[mm]								[mm]			[mm]	[g]	
with hub keyway, with machine handle EH 24450. assembled, form N-F/G (formerly: F 3) – picture 2													
100	10	25.5	M 6	16	33.0	17	50	3	11.4	3	16	473	24591.0505
125	12	27.0	M 8	20	35.5	18	64	4	13.8	3	20	753	24591.0510
140	14	29.0	M 8	20	38.5	19	64	5	16.3	3	20	939	24591.0515
160	14	31.0	M10	25	39.5	20	80	5	16.3	3	25	1282	24591.0520
200	18	37.0	M10	25	44.5	24	80	6	20.8	3	25	2000	24591.0530

Compliance

RoHS compliant

Compliant according to Directive 2011/65/EU and Directive 2015/863.

Does not contain SVHC substances

No SVHC substances with more than 0.1% w/w contained - SVHC list [REACH] as of 23.01.2024.

Does not contain Proposition 65 substances

No Proposition 65 substances included.

<https://www.P65Warnings.ca.gov/>

Free from Conflict Minerals

This product does not contain any substances designated as "conflict minerals" such as tantalum, tin, gold or tungsten from the Democratic Republic of Congo or adjacent countries.