

Swing Bolts • DIN 444, form B, quality 8.8 high precision design EH 22980.



Product Description

The high precision design swing bolts exceed the DIN Version's quality. The thread is rolled - the shaft diameter is equal to the roll diameter. The surfaces -s- are machined. Bore tolerance $d_2 = H7$.

Material

- Heat-treated steel, tempered, quality 8.8, black

More information

References

For torques please refer to appendix - Technical Data -

Further products

- Swing Bolts, DIN 444, form B

Drawing

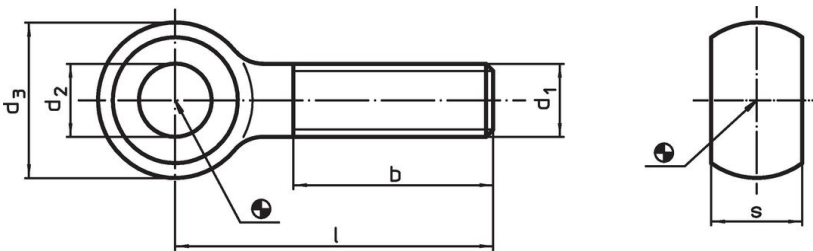

Order information

d ₁	l	Dimensions				s -0.2	[g]	Art. No.
		d ₂ H7 [mm]	d ₃	b				
M 8	40	8	18	22	9	28	22980.0081	
M 8	60	8	18	22	9	28	22980.0084	
M10	50	10	20	26	12	38	22980.0103	
M10	75	10	20	26	12	50	22980.0106	
M10	100	10	20	26	12	62	22980.0108	
M12	60	12	25	30	14	70	22980.0122	
M12	80	12	25	30	14	84	22980.0125	
M12	120	12	25	30	14	113	22980.0128	
M16	80	16	32	38	17	153	22980.0163	
M16	150	16	32	44	17	245	22980.0168	

Application example

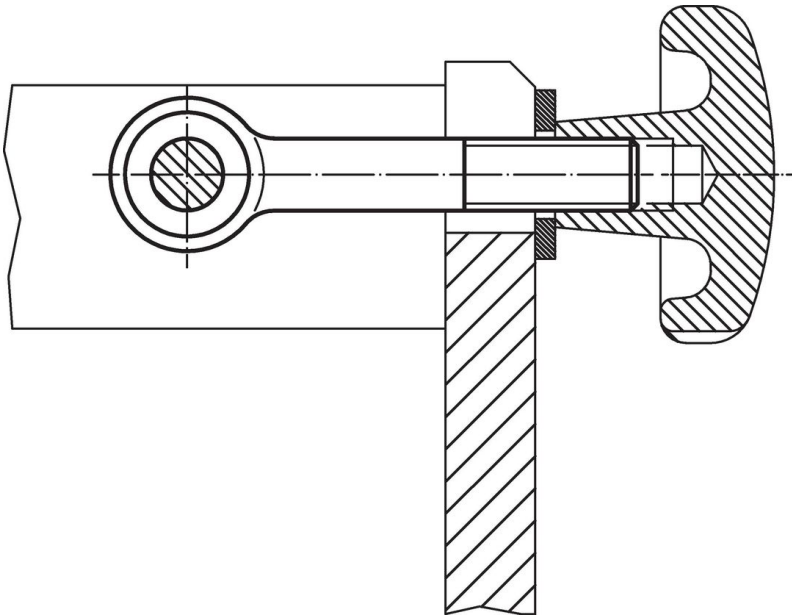

Compliance

For detailed compliance information please select the desired article number.