

## Index Plungers · with hexagon collar and locking, stainless steel EH 22120.



### Product Description

Index plungers are used for indexing bores.

#### Material

##### Body

- Stainless steel 1.4305

##### Locking pin

- Stainless steel 1.4305, nickel-plated

##### Knob

- Stainless steel 1.4305

#### Assembly

The screw length can be adapted by distance collars for index plungers (EH 22120.).

#### Operation

The knob is pulled-out, turned 90° and secured by a notched catch (when locking pin should not overhang).

#### More information

#### Notes

Knob not removable.  
Lock nuts have to be purchased separately.

#### Further products

- Mounting Blocks, for index bolts and index plungers, die-cast
- Distance Collars, for index plungers

### Drawing

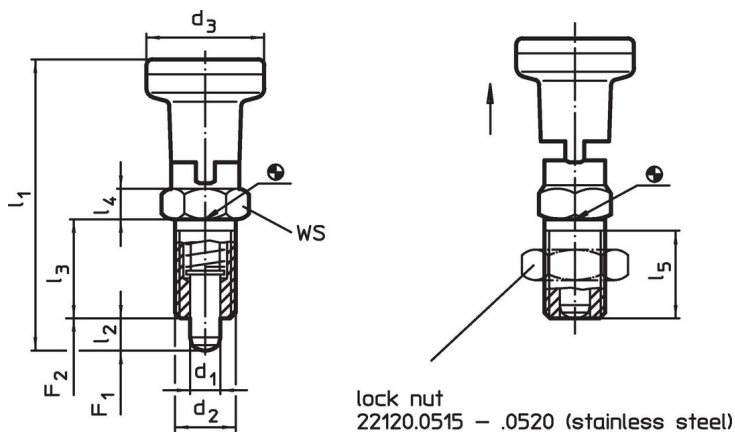

### Order information

d <sub>1</sub> -0.02 -0.05	d <sub>2</sub>	d <sub>3</sub>	Dimensions					WS [mm]	Spring load <sup>1)</sup>		max. [°C]	[g]	Art. No.
			l <sub>1</sub> ~ [mm]	l <sub>2</sub> min.	l <sub>3</sub>	l <sub>4</sub>	l <sub>5</sub> min.		F <sub>1</sub> ~ [N]	F <sub>2</sub> ~			
<b>Stainless steel</b>													
5	M10 x 1	21	51.0	5	17	5	15	12	6.0	14	250	43	<a href="#">22120.0615</a>
6	M12 x 1,5	25	61.0	6	20	6	17	14	6.5	19	250	71	<a href="#">22120.0616</a>
8	M16 x 1,5	31	75.5	7	26	8	23	19	11.5	28	250	144	<a href="#">22120.0618</a>
10	M20 x 1,5	31	91.0	10	33	10	30	22	28.0	54	250	203	<a href="#">22120.0620</a>

<sup>1)</sup> statistical average value

### Accessories

	Dimensions		Wrench size	[g]	Art. No.
	d <sub>2</sub> [mm]	[mm]			
<b>Lock nuts ISO 8675 (DIN 439), Stainless steel</b>					
	M10 x 1		16	5.2	<a href="#">22120.0515</a>
	M12 x 1,5		18	7.5	<a href="#">22120.0516</a>
	M16 x 1,5		24	15.0	<a href="#">22120.0518</a>
	M20 x 1,5		30	32.0	<a href="#">22120.0520</a>

### Application example

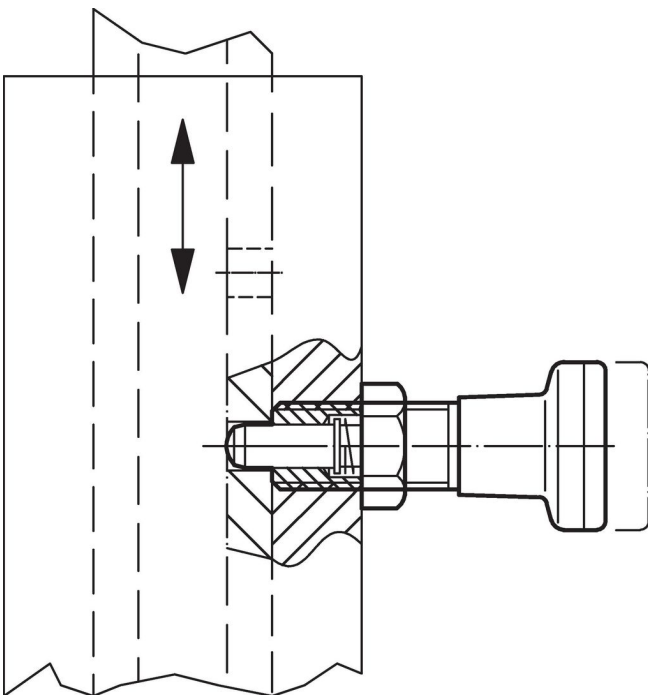

### Compliance

For detailed compliance information please select the desired article number.