

Taper Clamping Units • plain / ribbed, M8
23250.0501

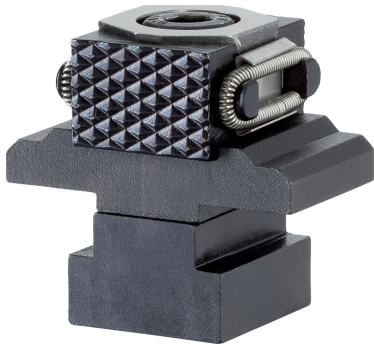

Product Description

Inserting the socket head screw moves the two clamping chucks outwards and presses the workpieces against a stop. Stroke of taper clamping units with M8 = +/- 0.5 mm, M12 = +/- 1 mm.

Material

Body

- Tool steel, hardened, bright

Screw

- Heat-treated steel, tempered, quality 12.9

Spring

- Spring steel wire

Clamping jaws

- Tool steel, hardened, blackened and ground

More information

Notes

Clamping jaws protected against rotating

Further products

- Taper Clamping Units

Drawing

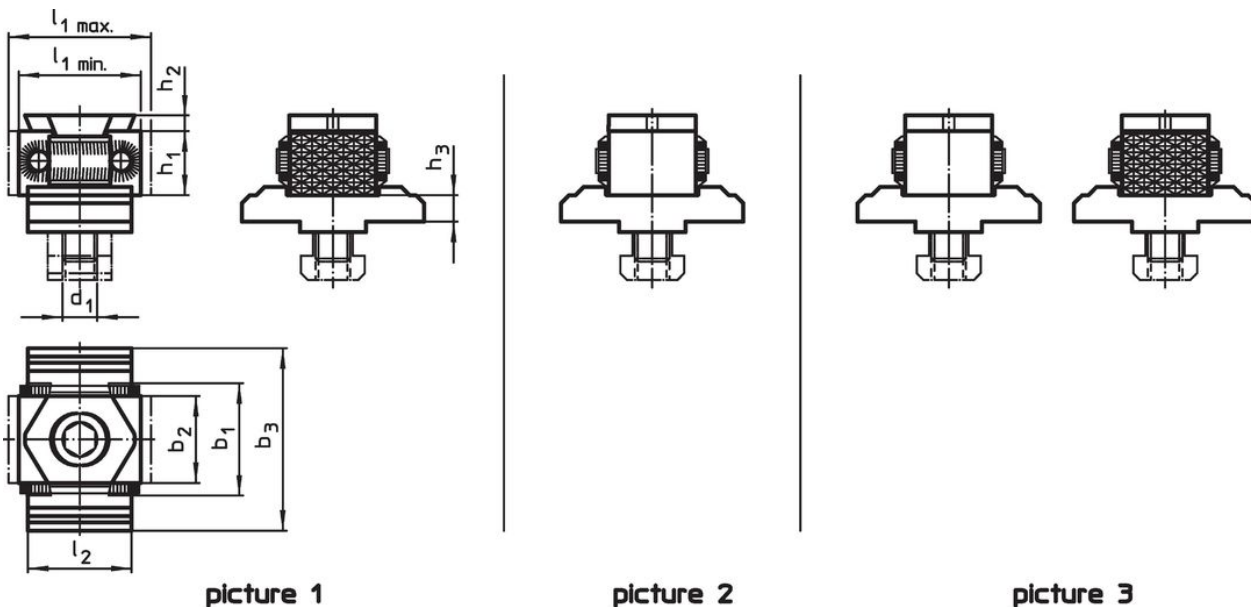

Order information

Dimensions										[g]	Art. No.	
d ₁	l ₁ min.	l ₁ max.	l ₂	b ₁	b ₂	b ₃	h ₁	h ₂	h ₃			
clamping jaw, ribbed on both sides – picture 1												
M8	27	31	25	29	21	44	15	2.5	6.4	206	23250.0501	

Compliance

RoHS compliant

Compliant according to Directive 2011/65/EU and Directive 2015/863.

Does not contain SVHC substances

No SVHC substances with more than 0.1% w/w contained - SVHC list [REACH] as of 27.06.2024.

Does not contain Proposition 65 substances

No Proposition 65 substances included.

<https://www.P65Warnings.ca.gov/>

Free from Conflict Minerals

This product does not contain any substances designated as "conflict minerals" such as tantalum, tin, gold or tungsten from the Democratic Republic of Congo or adjacent countries.