

Poignées fixes · DIN 39
EH 24450.



Description produit

Matières

- acier, tourné, zingué par galvanisation, passivé
- inox 1.4404

Plan

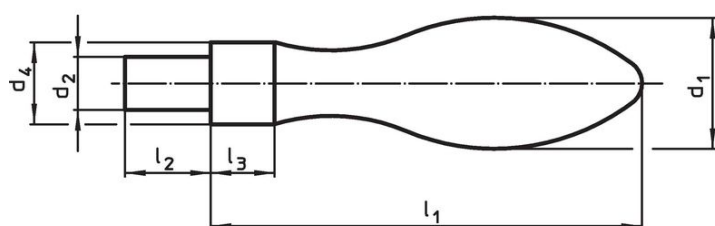

croquis 1

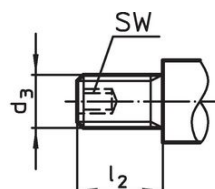

croquis 2

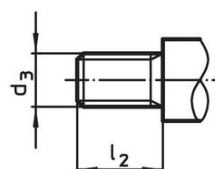

croquis 3

Informations détaillées

d ₁	d ₂ h8	d ₃	Dimensions				SW	[g]	Référence article
			d ₄ h13 [mm]	l ₁ ~	l ₂	l ₃			
avec tenon lisse, forme D – croquis 1, acier									
16	7	–	10	50	11	7	–	45	24450.0016
20	8	–	13	64	13	8	–	92	24450.0020
25	10	–	16	80	14	10	–	179	24450.0025
32	13	–	20	100	21	13	–	356	24450.0032
36	16	–	22	112	26	14	–	519	24450.0036
filetée, forme E – croquis 2, acier									
16	–	M 6	10	50	11	7	3	43	24450.0116
20	–	M 8	13	64	13	8	4	88	24450.0120
25	–	M10	16	80	14	10	5	175	24450.0125
32	–	M12	20	100	21	13	6	340	24450.0132
36	–	M16	22	112	26	14	8	509	24450.0136
filetée, forme E – croquis 3, inox									
16	–	M 6	10	50	11	7	–	45	24450.0316
20	–	M 8	13	64	13	8	–	92	24450.0320
25	–	M10	16	80	14	10	–	186	24450.0325

Exemple d'application

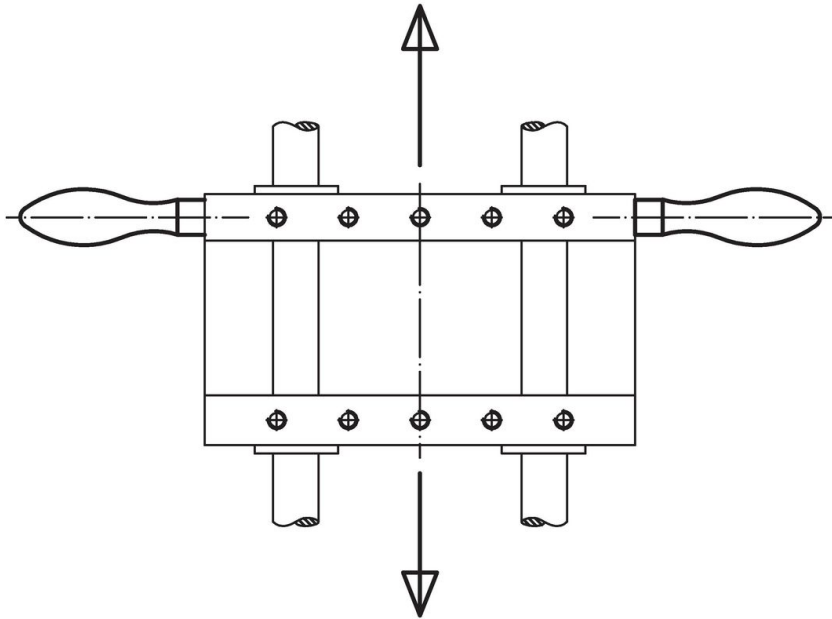

Conformité

Pour obtenir les informations détaillées sur la conformité choisissez le numéro d'article souhaité.