

Eccentric Clamping Clamps · with slot tenon

EH 23270.



Product Description

The eccentric clamping clamps can be used for quick and easy workpiece clamping directly on the machine table or a base plate with T-slots.

These eccentric clamping clamps with slot tenon are locked in a T-slot, for example on the machine table, with a thrust screw. Clamping takes place via the clamping screw with eccentric head. The brass base element ensures gentle and secure clamping.

The eccentric clamping clamps with slot tenon have the following characteristics:

- Brass base element for material-friendly clamping
- Quick clamping thanks to clamping screw with eccentric head
- High clamping force is achieved
- Low design enables the machining of flat workpieces
- The compact dimensions enable space-saving multiple clamping

Material

Eccentric screw

- Steel

Grub Screw

- Steel, blackened

Body

- Brass

Slot tenon

- Steel, hardened, blackened

Drawing

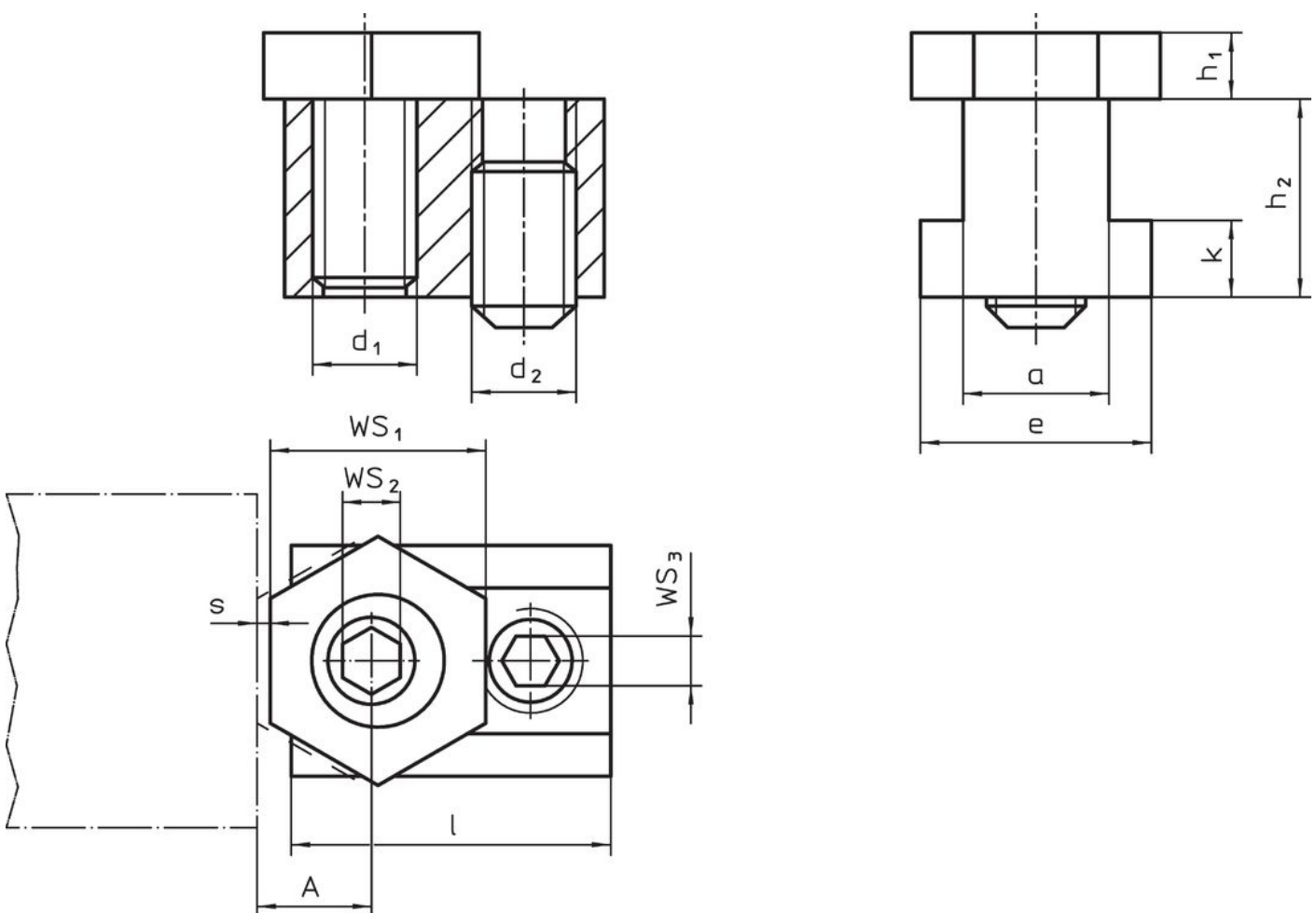

Order information

T-slot size	d ₁	a	e	Dimensions					A	WS ₁	WS		Clamping force max.	Tightening torque WS ₂ max.	Tightening torque WS ₃ max.	📦	Art. No.
				h ₁	h ₂	k	s	l			WS ₂	WS ₃					
[mm]				[mm]					[mm]		[mm]		[kN]	[Nm]	[Nm]	[g]	
10	M 6	9.8	14.3	4.8	14.3	4.4	1.0	23.2	7.8	16.0	4	3	3.4	10	8	35	23270.0410
14	M10	13.7	22.1	6.4	22.1	8.1	1.3	30.5	10.2	20.6	7	5	7.0	26	35	100	23270.0414
18	M12	17.7	28.5	9.5	28.5	10.5	2.5	34.7	12.7	25.4	8	6	9.0	75	55	190	23270.0418

Application example

