

Collar Nuts • DIN 6331 (height 1,5 d) EH 23080.

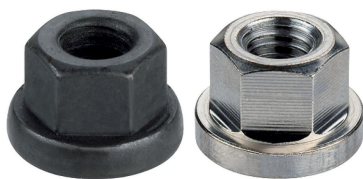

Product Description

The collar nuts (flanged nuts) are manufactured according to DIN 6331.

Material

- Heat-treated steel, tempered, quality 10, phosphated
- Stainless steel 1.4305

More information

References

For torques and strengths please refer to appendix - Technical Data -

Drawing

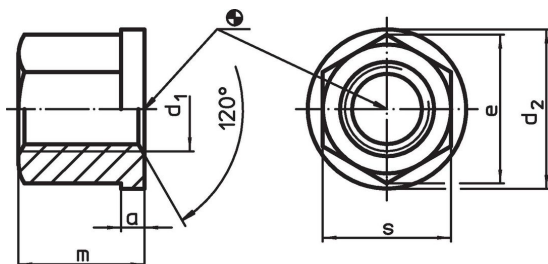

Order information

d ₁	a	Dimensions				s	[g]	Art. No.
		d ₂	e	m	[mm]			
Heat-treated steel								
M 6	3.0	14	11.5	9	10	5.4	23080.0006	
M 8	3.5	18	15.0	12	13	12.0	23080.0008	
M10	4.0	22	18.5	15	16	22.0	23080.0010	
M12	4.0	25	20.8	18	18	30.0	23080.0012	
M14	4.5	28	24.2	21	21	47.0	23080.0014 ¹⁾	
M16	5.0	31	27.7	24	24	67.0	23080.0016	
M18	5.5	34	31.2	27	27	97.0	23080.0018 ¹⁾	
M20	6.0	37	34.6	30	30	129.0	23080.0020	
M22	6.0	40	39.3	33	34	179.0	23080.0022 ¹⁾	
M24	6.0	45	41.6	36	36	213.0	23080.0024	
M30	8.0	58	53.1	45	46	468.0	23080.0030	
M36	10.0	68	63.5	54	55	783.0	23080.0036	
Stainless steel								
M 8	3.5	18	15.0	12	13	12.0	23080.0108 ²⁾	
M10	4.0	22	18.5	15	17	25.0	23080.0110 ²⁾	
M12	4.0	25	20.8	18	19	36.0	23080.0112 ²⁾	
M16	5.0	31	27.7	24	24	67.0	23080.0116 ²⁾	
M20	6.0	37	34.6	30	30	129.0	23080.0120 ²⁾	

¹⁾ DIN standards do not include these dimensions.

²⁾ DIN standard do not include these material.

Application example

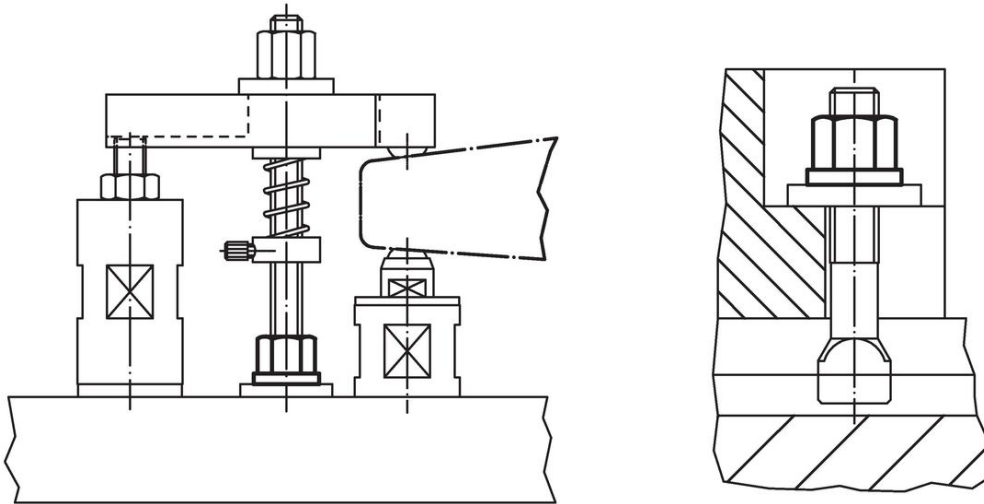

Compliance

For detailed compliance information please select the desired article number.