

Ball Casters · with mounting elements

EH 22750.



Product Description

Ball casters are module for transport systems, conveyances, to working and packing facilities. For example, parts can be easily moved, turned and controlled.

Material

Cap

- Steel, zinc-plated by galvanization

Housing

- Steel, zinc-plated by galvanization

Ball

- Ball-bearing steel
- Stainless steel

Assembly

Mounting is carried-out by means of spring-loaded claws allowing big tolerances in the location hole.

The ball casters can easily be mounted and disassembled from their functional side.

Due to the inclined cap form, the assembly mandrel EH 22750. should be used.

Drawing

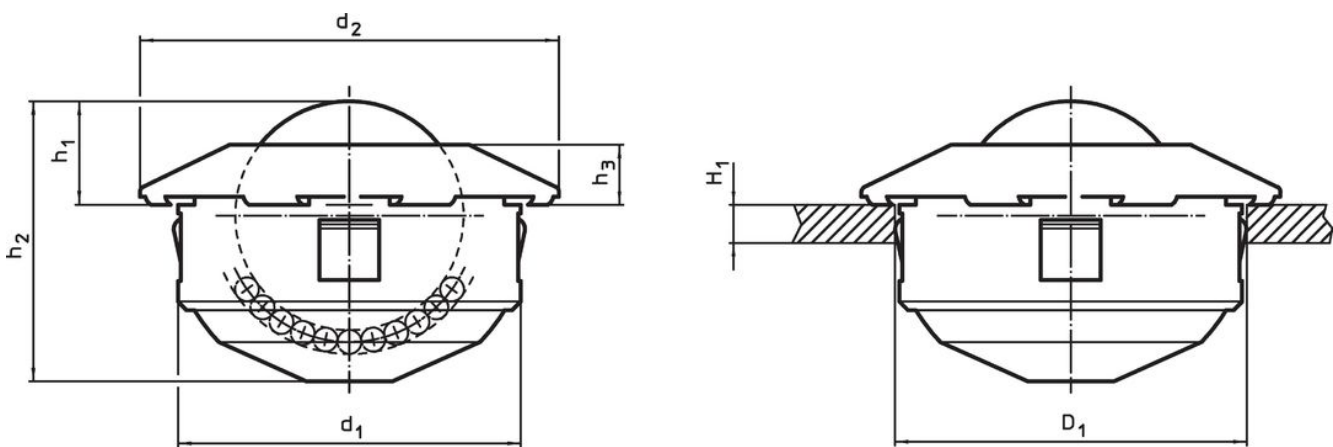

Order information

d ₁	Ball diameter	Dimensions				h ₁ min.	Location hole D ₁	Dynamic carrying figure C	[g]	Art. No.
		d ₂	h ₁	h ₂	h ₃					
[mm]										
ball from ball-bearing steel										
24-0.13	15	31	9.5±0.2	20.5	5.5	1.5	24	500	42	22750.0104
36-0.16	22	45	9.8±0.2	28.6	6.0	2.0	36	1300	144	22750.0108
45-0.16	30	55	13.8±0.3	37.5	8.0	2.5	45	2500	292	22750.0112
ball from stainless steel										
24-0.13	15	31	9.5±0.2	20.5	5.5	1.5	24	370	42	22750.0124
36-0.16	22	45	9.8±0.2	28.6	6.0	2.0	36	970	143	22750.0128
45-0.16	30	55	13.8±0.3	37.5	8.0	2.5	45	1900	290	22750.0132

Accessories

	Suitable for ball caster		Art. No.
	[mm]	[g]	
assembly tool			
	24	451	22750.0144
	36	480	22750.0148
	45	503	22750.0152

Application example

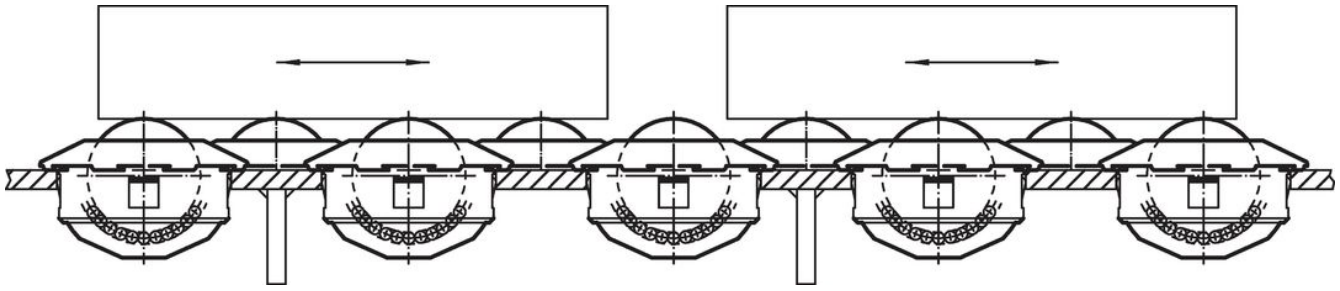

Compliance

For detailed compliance information please select the desired article number.