

## Lateral Plungers · with thread, without seal

EH 22150.



### Product Description

To be used for positioning and applying pressure, e.g. during painting and sandblasting.

#### Material

##### Body

- Steel, zinc-plated by galvanization

##### Spring

- Stainless steel
- Steel, blackened
- Steel, zinc-plated by galvanization

##### Pin

- Steel, case-hardened, zinc-plated by galvanization
- Thermoplastic POM, white

#### Assembly

Lateral plungers are installed by screwing in by means of a mounting tool.

Formula for calculating the center distance for the mounting hole:

$$l_0 = z/2 + w + x,$$

$l_0$  = center distance,

$y$  = workpiece height,

$w$  = workpiece length,

$x$  = coordinate dimension,

$s$  = stroke,

$z$  = stop diameter

Calculation dimension  $x$ :

$y$  greater than or equal to  $l_2 - d_2/2$ ,

then  $x = d_2/2 - s$

(value  $x$  for this case see table)

or

$y$  smaller than  $l_2 - d_2/2$ ,

then  $x = d_2/2 - s - [(l_2 - d_2/2 - y) * 0,123]$

#### Characteristic

Version light spring load = spring from stainless steel

Version standard spring load = spring from steel, blackened

Version heavy spring load = spring from steel, zinc-plated by galvanization

### Drawing

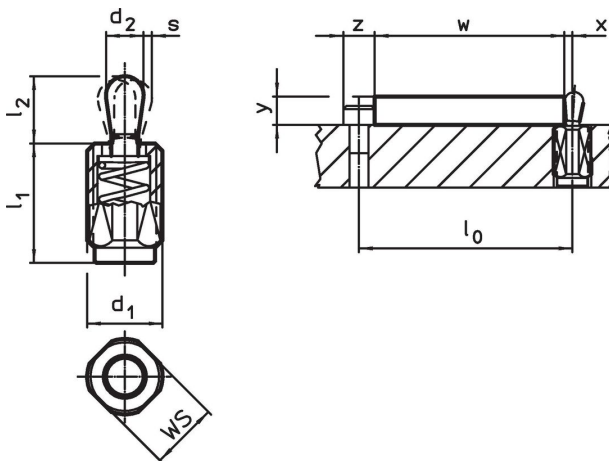



Order information

d <sub>1</sub> [mm]	Dimensions		d <sub>2</sub> [mm]	l <sub>2</sub> [mm]	Stroke s [mm]	WS [mm]	x <sup>1)</sup> [mm]	max. [°C]	 [g]	Art. No.
	l <sub>1</sub> -2	Spring load F max. <sup>2)</sup> ~ [N]								
<b>Pin: Steel/Light spring load</b>										
M12	11.5	20	5	6.4	0.8	10	1.7	250	4.0	22150.0310
M12	19.0	20	5	6.4	0.8	10	1.7	250	5.9	22150.0314
M12	26.5	20	5	6.4	0.8	10	1.7	250	7.9	22150.0318
M12	11.5	40	6	10.4	1.0	10	2.0	250	4.8	22150.0330
M12	19.0	40	6	10.4	1.0	10	2.0	250	6.6	22150.0334
M12	26.5	40	6	10.4	1.0	10	2.0	250	8.6	22150.0338
M18 x 1,5	18.0	100	10	16.9	1.6	16	3.4	250	19.0	22150.0350
M18 x 1,5	31.5	100	10	16.9	1.6	16	3.4	250	28.0	22150.0354
M18 x 1,5	45.0	100	10	16.9	1.6	16	3.4	250	36.0	22150.0358
<b>Pin: Steel/Standard spring load</b>										
M12	11.5	50	5	6.4	0.8	10	1.7	250	4.1	22150.0311
M12	19.0	50	5	6.4	0.8	10	1.7	250	6.4	22150.0315
M12	26.5	50	5	6.4	0.8	10	1.7	250	8.3	22150.0319
M12	11.5	75	6	10.4	1.0	10	2.0	250	4.9	22150.0331
M12	19.0	75	6	10.4	1.0	10	2.0	250	7.1	22150.0335
M12	26.5	75	6	10.4	1.0	10	2.0	250	9.6	22150.0339
M18 x 1,5	18.0	150	10	16.9	1.6	16	3.4	250	20.0	22150.0351
M18 x 1,5	31.5	150	10	16.9	1.6	16	3.4	250	29.0	22150.0355
M18 x 1,5	45.0	150	10	16.9	1.6	16	3.4	250	39.0	22150.0359
<b>Pin: Steel/Heavy spring load</b>										
M12	11.5	100	5	6.4	0.8	10	1.7	250	4.4	22150.0312
M12	19.0	100	5	6.4	0.8	10	1.7	250	6.9	22150.0316
M12	26.5	100	5	6.4	0.8	10	1.7	250	9.0	22150.0320
M12	11.5	100	6	10.4	1.0	10	2.0	250	5.4	22150.0332
M12	19.0	100	6	10.4	1.0	10	2.0	250	7.7	22150.0336
M12	26.5	100	6	10.4	1.0	10	2.0	250	10.0	22150.0340
M18 x 1,5	18.0	200	10	16.9	1.6	16	3.4	250	21.0	22150.0352
M18 x 1,5	31.5	200	10	16.9	1.6	16	3.4	250	30.0	22150.0356
M18 x 1,5	45.0	200	10	16.9	1.6	16	3.4	250	40.0	22150.0360
<b>Pin: Thermoplastic/Light spring load</b>										
M12	11.5	20	5	6.4	0.8	10	1.7	80	2.7	22150.0370
M12	19.0	20	5	6.4	0.8	10	1.7	80	4.6	22150.0375
M12	26.5	20	5	6.4	0.8	10	1.7	80	6.5	22150.0383
M12	11.5	40	6	10.4	1.0	10	2.0	80	3.1	22150.0373
M12	19.0	40	6	10.4	1.0	10	2.0	80	4.8	22150.0380
M12	26.5	40	6	10.4	1.0	10	2.0	80	6.8	22150.0385
M18 x 1,5	18.0	100	10	16.9	1.6	16	3.4	80	12.0	22150.0390
M18 x 1,5	31.5	100	10	16.9	1.6	16	3.4	80	20.0	22150.0393
M18 x 1,5	45.0	100	10	16.9	1.6	16	3.4	80	30.0	22150.0395

<sup>1)</sup> If the workpiece height (y) is less than l<sub>2</sub>-d<sub>2</sub>/2, the coordinate dimension (x) must be calculated.

<sup>2)</sup> statistical average value

Accessories

	Dimensions		Art. No.
	d <sub>1</sub> [mm]		
<b>assembly tool</b>			
	M12	76	22150.0820
	M18 x 1,5	137	22150.0822

Application example

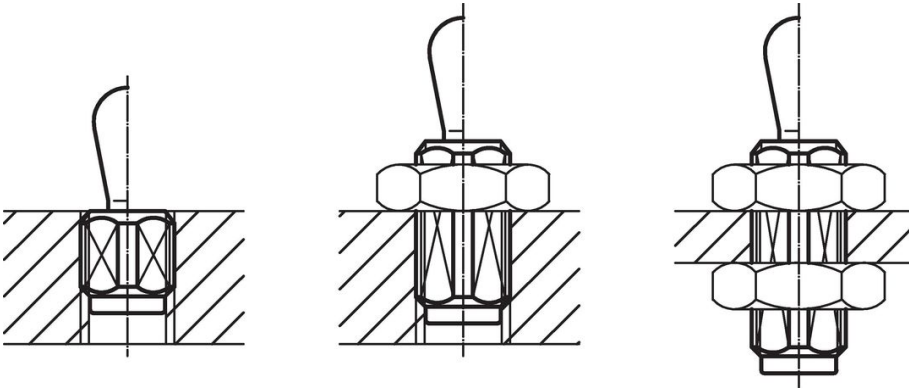

Compliance

For detailed compliance information please select the desired article number.