

Clamping Cubes • welded, semi-finished EH 1910.



Product Description

Material

- Steel, welded

More information

Notes

Special plates on request.

Drawing

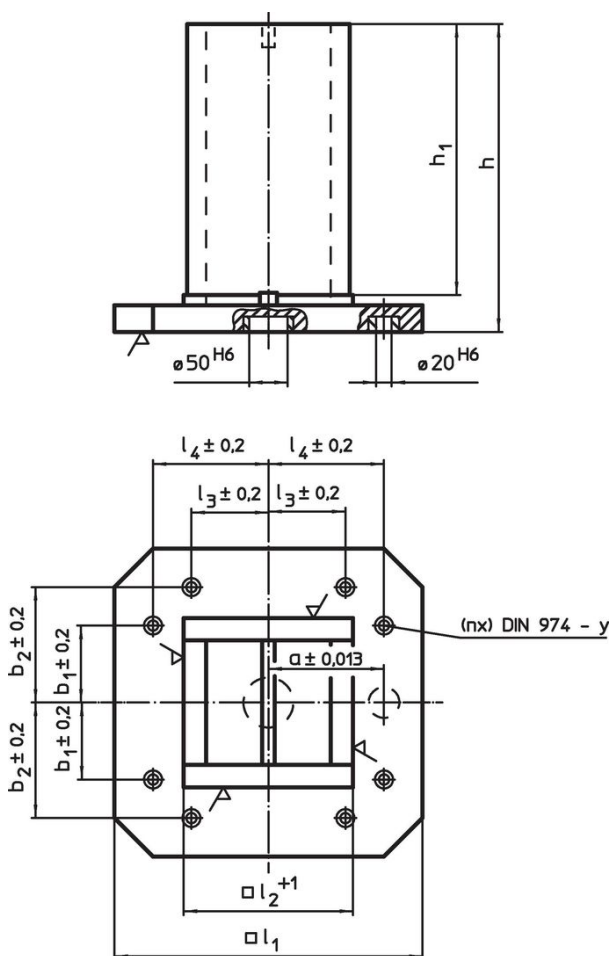

Order information

l_1	l_2^{+1}	$l_3 \pm 0.2$	$l_4 \pm 0.2$	Dimensions			$a \pm 0.013$	$b_1 \pm 0.2$	$b_2 \pm 0.2$	y	For screws	Number of fastening holes n	 [kg]	Art. No.
				h	h_1	[mm]								
400	231	–	150	500	450	150	150	–	12	M12	4	134	1910.220	
500	331	–	200	650	595	200	200	–	12	M12	4	265	1910.240	
630	451	200	300	800	740	200	200	300	16	M16	8	427	1910.260	

Application example



Compliance

RoHS compliant

Contains lead - compliant according to exceptions 6a / 6b / 6c.

Contains SVHC substances >0,1% w/w

Contains lead - SVHC list [REACH] as of 27.06.2024.

Contains Proposition 65 substances



Lead can cause cancer and reproductive harm from exposure
<https://www.P65Warnings.ca.gov/>

Free from Conflict Minerals

This product does not contain any substances designated as "conflict minerals" such as tantalum, tin, gold or tungsten from the Democratic Republic of Congo or adjacent countries.