

## Double Edge Clamps · machinable chucks

23251.0116



### Product Description

Inserting the socket head screw moves the two clamping chucks outwards and presses the workpiece against a stop. The chucks can be machined to the needed workpiece contour. The locking plate is needed only for this machining, not for the workpiece clamping.

### Material

- Body**
  - Aluminium Al
- Taper**
  - Case-hardened steel, blackened
- Screw**
  - Steel
- Locking plate**
  - Aluminium Al

### Assembly

Can be mounted in a threaded hole or with T-nuts for horizontal or vertical multiple clamping.

### More information

### Accessories

T-nuts EH 23010. have to be purchased separately.

### Further products

- Nuts for T-Slots, DIN 508

### Drawing

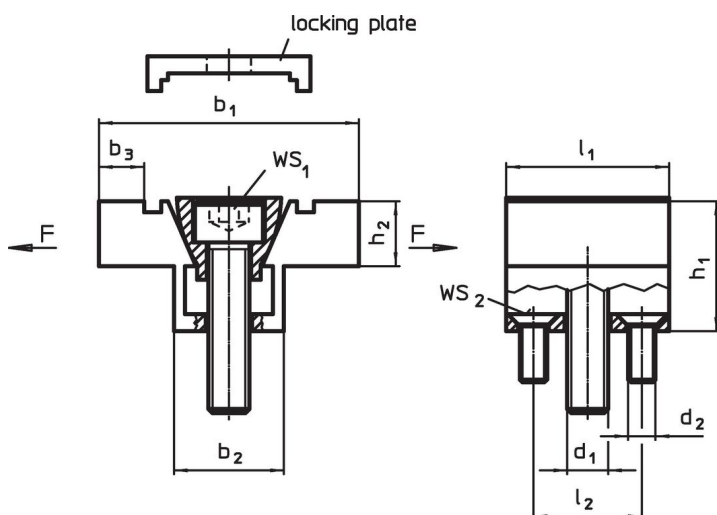

### Order information

Dimensions			WS <sub>1</sub>	WS <sub>2</sub>	Clamping force max.	Tightening torque max.	Art. No.							
b <sub>1</sub>	b <sub>2</sub>	b <sub>3</sub> <sup>1)</sup>						[mm]	[mm]	[kN]	[Nm]	[g]		
101.6	41.3	20.3	50.8	25.4	63.5	41.3	M16	M6	14	4	26.7	74.6	1068	23251.0116

<sup>1)</sup> machinable material allowance

### Application example



### Compliance

#### RoHS compliant

Compliant according to Directive 2011/65/EU and Directive 2015/863.

#### Does not contain SVHC substances

No SVHC substances with more than 0.1% w/w contained - SVHC list [REACH] as of 23.01.2024.

#### Does not contain Proposition 65 substances

No Proposition 65 substances included.

<https://www.P65Warnings.ca.gov/>

#### Free from Conflict Minerals

This product does not contain any substances designated as "conflict minerals" such as tantalum, tin, gold or tungsten from the Democratic Republic of Congo or adjacent countries.