

## Swing Bolts • DIN 444, form B, quality 8.8 high precision design

22980.0081



### Product Description

The high precision design swing bolts exceed the DIN Version's quality. The thread is rolled - the shaft diameter is equal to the roll diameter. The surfaces -s- are machined. Bore tolerance  $d_2 = H7$ .

### Material

- Heat-treated steel, tempered, quality 8.8, black

### More information

#### References

For torques please refer to appendix - Technical Data -

#### Further products

- Swing Bolts, DIN 444, form B

### Drawing

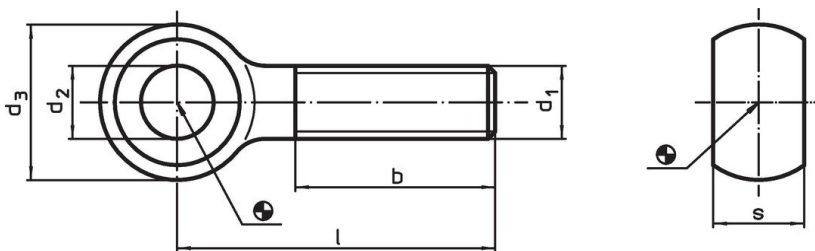

### Order information

| Dimensions |     |             |       |     |             | [g] | Art. No.   |
|------------|-----|-------------|-------|-----|-------------|-----|------------|
| $d_1$      | $l$ | $d_2$<br>H7 | $d_3$ | $b$ | $s$<br>-0.2 |     |            |
| [mm]       |     |             |       |     |             |     |            |
| M8         | 40  | 8           | 18    | 22  | 9           | 28  | 22980.0081 |

### Application example

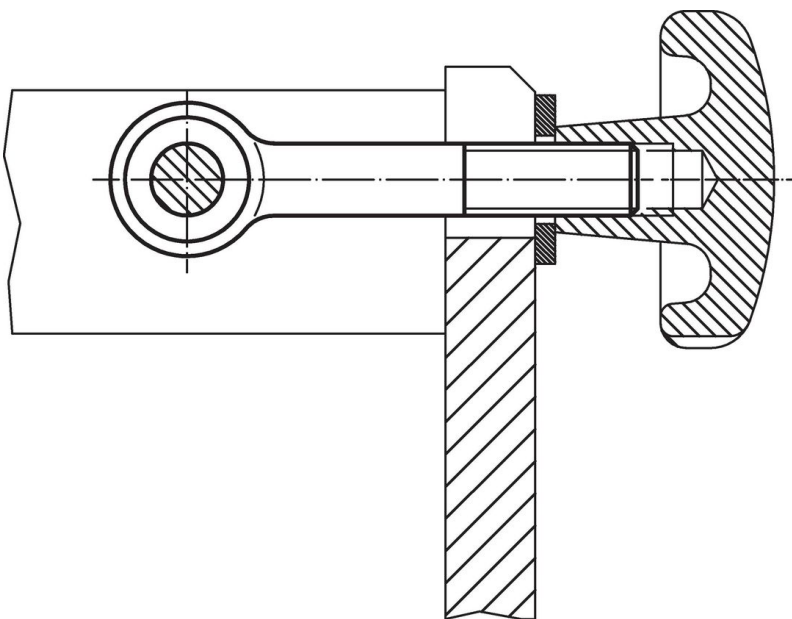

## Compliance

### RoHS compliant

Contains lead - compliant according to exceptions 6a / 6b / 6c.

### Contains SVHC substances >0,1% w/w

Contains lead - SVHC list [REACH] as of 23.01.2024.

### Contains Proposition 65 substances



Lead can cause cancer and reproductive harm from exposure  
<https://www.P65Warnings.ca.gov/>

### Free from Conflict Minerals

This product does not contain any substances designated as "conflict minerals" such as tantalum, tin, gold or tungsten from the Democratic Republic of Congo or adjacent countries.