

## Lateral Plungers · smooth, with seal, with female thread

22150.1121



### Product Description

To be used for positioning and applying pressure, e.g. during painting and sandblasting. Sealed against chips and dirt.

### Material

#### Seal

- CR

#### Body

- Aluminium Al

#### Threaded washer

- Steel, blackened

#### Spring

- Steel, blackened

### Assembly

Formula for calculating the center distance for the mounting hole:

$$l_0 = z/2 + w + x,$$

$l_0$  = center distance,

$y$  = workpiece height,

$w$  = workpiece length,

$x$  = stroke,

$z$  = stop diameter

Calculation dimension  $x$  for workpieces:

$$x = d_2/2 - s$$

Installation by pressing in.

### Characteristic

Version standard spring load = spring from steel, blackened

### More information

### Notes

Individual set screws can be screwed in the plate with threaded hole.

### Further products

- Eccentric Mounting Bushings, for lateral plungers, smooth

### Drawing

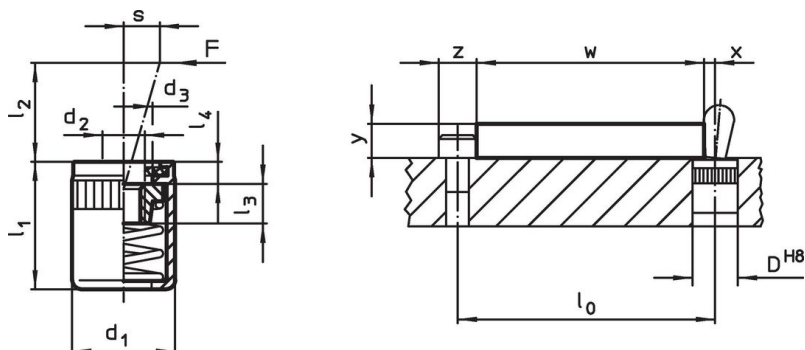



### Order information

Dimensions		Spring load F max. <sup>1)</sup> [N]	Dimensions					Stroke s [mm]	Location hole D H8 [mm]	max. [°C]	[g]	Art. No.
d <sub>1</sub>	d <sub>2</sub>		d <sub>3</sub>	l <sub>1</sub> -2	l <sub>2</sub>	l <sub>3</sub>	l <sub>4</sub>					
[mm]	[mm]		[mm]	[mm]	[mm]	[mm]	[mm]	[mm]	[°C]	[g]		
Standard spring load												
10	M4	50	6.3	12	6	4.5	1.8	0.8	10	110	2.2	22150.1121

<sup>1)</sup> statistical average value

## Accessories

	Dimensions d <sub>1</sub> [mm]	 [g]	Art. No.
<b>assembly tool</b>			
	10	49	22150.0831

## Compliance

### RoHS compliant

Compliant according to Directive 2011/65/EU and Directive 2015/863.

### Does not contain SVHC substances

No SVHC substances with more than 0.1% w/w contained - SVHC list [REACH] as of 27.06.2024.

### Does not contain Proposition 65 substances

No Proposition 65 substances included.

<https://www.P65Warnings.ca.gov/>

### Free from Conflict Minerals

This product does not contain any substances designated as "conflict minerals" such as tantalum, tin, gold or tungsten from the Democratic Republic of Congo or adjacent countries.