

Epäkeskokiinnittimet • with slot tenon

23270.0418



Tuotekuvaus

The eccentric clamping clamps can be used for quick and easy workpiece clamping directly on the machine table or a base plate with T-slots.

These eccentric clamping clamps with slot tenon are locked in a T-slot, for example on the machine table, with a thrust screw. Clamping takes place via the clamping screw with eccentric head. The brass basic element ensures gentle and secure clamping.

The eccentric clamping clamps with slot tenon have the following characteristics:

- Brass base element for material-friendly clamping
- Quick clamping thanks to clamping screw with eccentric head
- High clamping force is achieved
- Low design enables the machining of flat workpieces
- The compact dimensions enable space-saving multiple clamping

Materiaali

Epäkeskoruuvi

- Teräs

Pallopäinen ruuvi

- Teräs, mustattu

Holkki

- Messinki

Slot tenon

- Teräs, karkaistu, mustattu

Piirustus

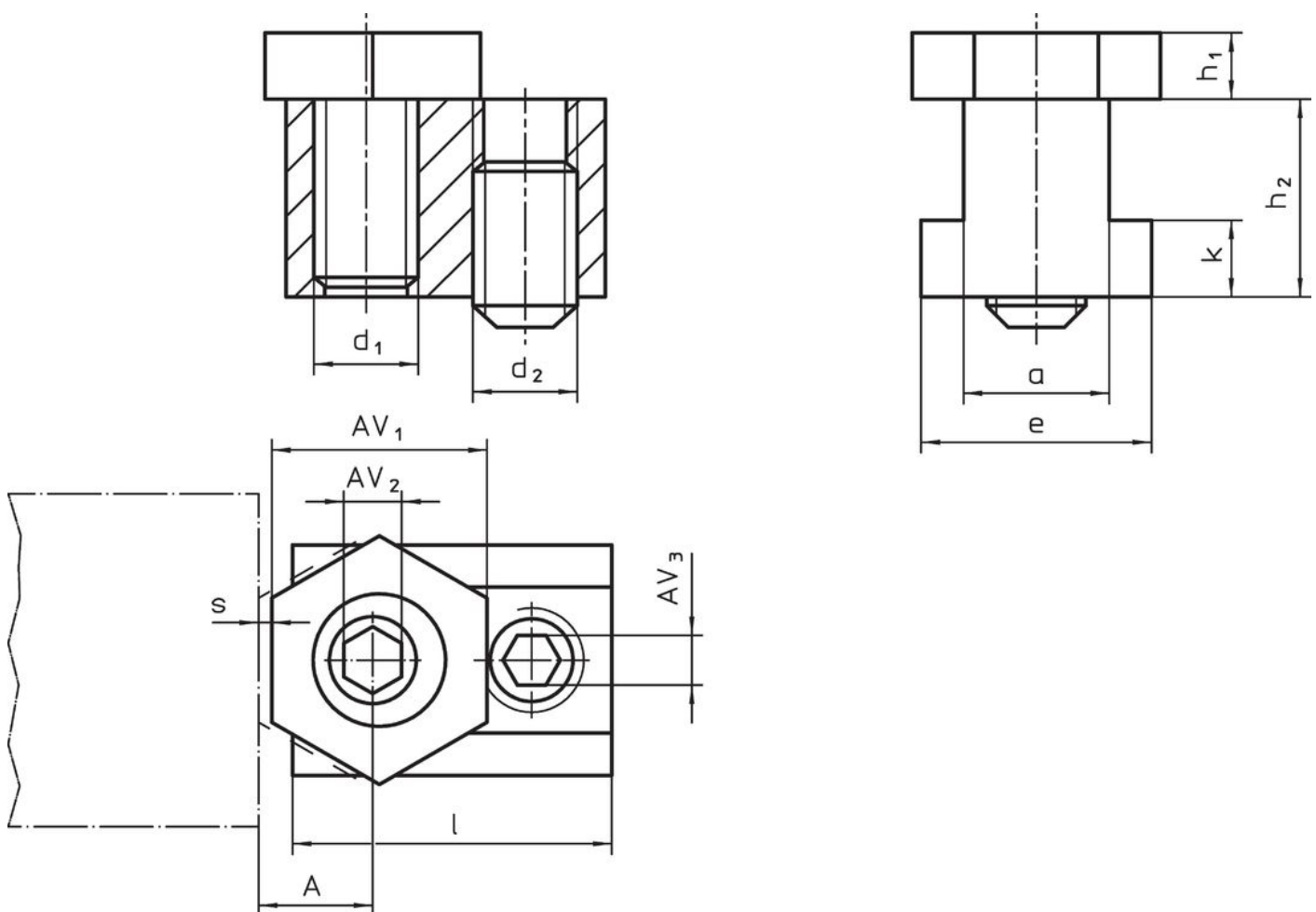

Tilastiedot

T- uramitta [mm]	d ₁	a	e	Ulkomitat [mm]					A [mm]	AV [mm]			Kiinnitys- voima max. [kN]	Kivistysmomentti AV ₂ max. [Nm]	Kivistysmomentti AV ₃ max. [Nm]	Til.nro	
				h ₁	h ₂	k	s	l		AV ₁	AV ₂	AV ₃					
18	M12	17,7	28,5	9,5	28,5	10,5	2,5	34,7	12,7	25,4	8	6	9	75	55	190	23270.0418

Sovellusesimerkki

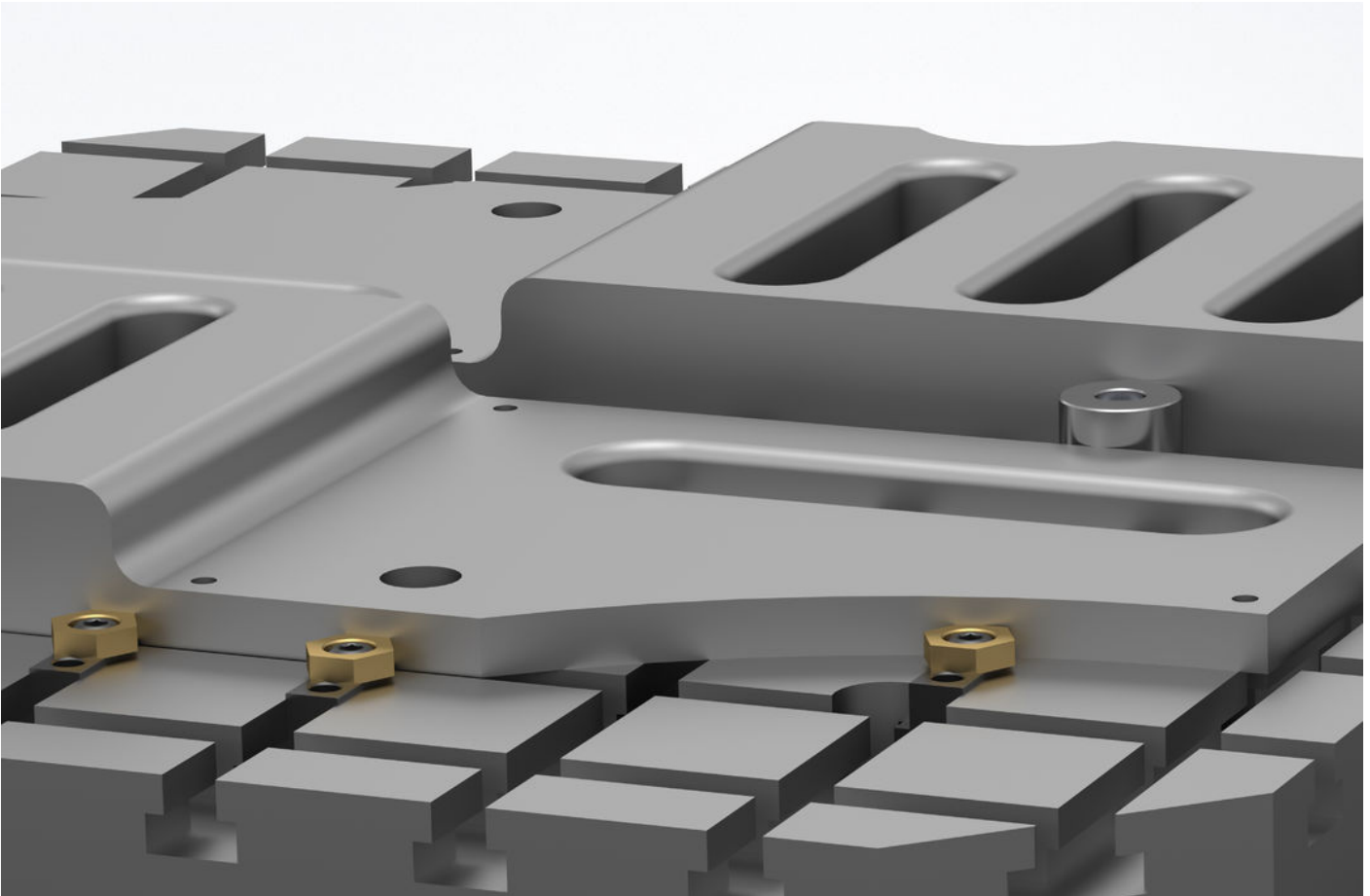

Vaatimuksenmukaisuus

Täyttävät direktiivin 2011/65/EU ja direktiivin 2015/863 vaatimukset

Ei sisällä yli 0,1 % w/w SVHC-aineita - SVHC-luettelo 23.01.2024.

Ei sisällä Prop 65 -aineita
<https://www.P65Warnings.ca.gov/>